



# Multicomponent reactions III

Edited by Thomas J. J. Müller

## Imprint

Beilstein Journal of Organic Chemistry  
[www.bjoc.org](http://www.bjoc.org)  
ISSN 1860-5397  
Email: [journals-support@beilstein-institut.de](mailto:journals-support@beilstein-institut.de)

The *Beilstein Journal of Organic Chemistry* is published by the Beilstein-Institut zur Förderung der Chemischen Wissenschaften.

Beilstein-Institut zur Förderung der  
Chemischen Wissenschaften  
Trakehner Straße 7–9  
60487 Frankfurt am Main  
Germany  
[www.beilstein-institut.de](http://www.beilstein-institut.de)

The copyright to this document as a whole, which is published in the *Beilstein Journal of Organic Chemistry*, is held by the Beilstein-Institut zur Förderung der Chemischen Wissenschaften. The copyright to the individual articles in this document is held by the respective authors, subject to a Creative Commons Attribution license.



## Multicomponent reactions III

Thomas J. J. Müller

### Editorial

Open Access

Address:

Heinrich-Heine Universität Düsseldorf, Institut für Organische Chemie und Makromolekulare Chemie, Universitätsstraße 1, D-40225 Düsseldorf, Germany

Email:

Thomas J. J. Müller - ThomasJJ.Mueller@uni-duesseldorf.de

Keywords:

MCR; multicomponent reactions

*Beilstein J. Org. Chem.* **2019**, *15*, 1974–1975.

doi:10.3762/bjoc.15.192

Received: 31 July 2019

Accepted: 09 August 2019

Published: 20 August 2019

This article is part of the thematic issue "Multicomponent reactions III".

Guest Editor: T. J. J. Müller

© 2019 Müller; licensee Beilstein-Institut.

License and terms: see end of document.

In times of steadily increasing relevance of sustainability and environmental concern, the concept of multicomponent reactions (MCRs) [1] has become a particularly powerful principle of synthetic design, combining synthetic efficiency with conceptual efficacy. The importance of rapid lead finding and identification has demanded novel ways of synthetic approaches, ultimately approaching the ideal synthesis [2,3]. As an evergreen in organic chemistry MCRs never became old-fashioned or tedious, because they always inspire creative spirits by following the fundamental quest: more than two compounds are reacted in a one-pot fashion to form two or more bonds. This fundamental principle, recognized by Ugi's groundbreaking developments in isonitrile-based chemistry directly leads to one-pot methodologies as a reactivity-based concept [4]. Reactive functionalities that are repetitively being generated and transformed represent the basis of the underlying general principle. Therefore, MCRs are equally intriguing for industrial applications as exciting and stimulating for academia, especially, for approaching new shores of interdisciplinarity by concatenating elementary steps to new sequences and ultimately to complex functional molecules in a one-pot fashion.

This thematic issue on multicomponent reactions proceeds the previously released issues from 2011 and 2014 [5,6]. Moreover, by the majority of the contributing authors it also becomes a vivid testimony of last year's 7th International Conference on Multicomponent Chemistry and Related Reactions that was held in Düsseldorf, Germany [7]. All contributions in this issue report or summarize recent developments of this highly dynamic field in a snap shot fashion. The agenda broadly spans over modern synthetic chemistry, from isonitrile and condensation-based MCRs over metal-catalyzed and mediated sequences to algorithms of synthetic efficiency. Biologically and pharmaceutically relevant scaffolds are likewise tackled as chromophores, methodology development and conceptual design of macro(hetero)cycles go hand in hand with MCR-based heterocyclic chemistry. As in the previous thematic issues also this issue opens the actual field of MCR chemistry to a broader interested community by five reviews on MCR based concepts.

As the guest editor of this thematic issue in the *Beilstein Journal of Organic Chemistry* I cordially thank all authors,

dedicated and excellent scientists, for sharing their exciting findings and, in particular, I am grateful to the staff of the Beilstein-Institut for their excellent support and professional realization.

Thomas J. J. Müller

Düsseldorf, July 2019

## ORCID® iDs

Thomas J. J. Müller - <https://orcid.org/0000-0001-9809-724X>

## References

1. Zhu, J.; Wang, Q.; Wang, M., Eds. *Multicomponent Reactions in Organic Synthesis*; Wiley-VCH: Weinheim, Germany, 2014.  
doi:10.1002/9783527678174
2. Wender, P. A.; Handy, S. T.; Wright, D. L. *Chem. Ind.* **1997**, 765, 767–769.
3. Gaich, T.; Baran, P. S. *J. Org. Chem.* **2010**, 75, 4657–4673.  
doi:10.1021/jo1006812
4. Müller, T. J. J. 1. *General Discussion and Reactions Involving a Carbonyl Compound as Electrophilic Component*. In *Multicomponent Reactions*; Müller, T. J. J., Ed.; Science of Synthesis Series, Vol. 1; Georg Thieme Verlag KG: Stuttgart, Germany, 2014; pp 5–27.  
doi:10.1055/sos-sd-210-00013
5. <https://www.beilstein-journals.org/bjoc/series/16> (accessed July 31, 2019).
6. <https://www.beilstein-journals.org/bjoc/series/39> (accessed July 31, 2019).
7. Müller, T. J. J.; Schaper, K. *Nachr. Chem.* **2019**, 67, 75.  
doi:10.1002/nadc.20194088380

## License and Terms

This is an Open Access article under the terms of the Creative Commons Attribution License (<http://creativecommons.org/licenses/by/4.0>). Please note that the reuse, redistribution and reproduction in particular requires that the authors and source are credited.

The license is subject to the *Beilstein Journal of Organic Chemistry* terms and conditions: (<https://www.beilstein-journals.org/bjoc>)

The definitive version of this article is the electronic one which can be found at:  
[doi:10.3762/bjoc.15.192](https://doi.org/10.3762/bjoc.15.192)



# Mn-mediated sequential three-component domino Knoevenagel/cyclization/Michael addition/oxidative cyclization reaction towards annulated imidazo[1,2-*a*]pyridines

Olga A. Storozhenko<sup>1</sup>, Alexey A. Festa<sup>\*1</sup>, Delphine R. Bella Ndoutoume<sup>1</sup>, Alexander V. Aksenov<sup>2</sup>, Alexey V. Varlamov<sup>1</sup> and Leonid G. Voskressensky<sup>\*1</sup>

## Full Research Paper

[Open Access](#)

### Address:

<sup>1</sup>Organic Chemistry Department, Peoples' Friendship University of Russia (RUDN University), Miklukho-Maklaya st. 6, 117198 Moscow, Russian Federation and <sup>2</sup>Department of Chemistry, North Caucasus Federal University, Pushkin st. 1a, 355009 Stavropol, Russian Federation

### Email:

Alexey A. Festa<sup>\*</sup> - festa\_aa@pfur.ru; Leonid G. Voskressensky<sup>\*</sup> - lvoskressensky@sci.pfu.edu.ru

\* Corresponding author

### Keywords:

2-aminochromene; domino reaction; imidazo[1,2-*a*]pyridine; 2-iminochromene; Michael addition; multicomponent reaction; oxidation; pyridine amination

*Beilstein J. Org. Chem.* **2018**, *14*, 3078–3087.

doi:10.3762/bjoc.14.287

Received: 05 September 2018

Accepted: 26 November 2018

Published: 19 December 2018

This article is part of the thematic issue "Multicomponent reactions III".

Guest Editor: T. J. J. Müller

© 2018 Storozhenko et al.; licensee Beilstein-Institut.

License and terms: see end of document.

## Abstract

The sequential three-component reaction between *o*-hydroxybenzaldehydes, *N*-(cyanomethyl)pyridinium salts and a nucleophile towards substituted chromenoimidazopyridines under oxidative conditions has been developed. The employment of Mn(OAc)<sub>3</sub>·2H<sub>2</sub>O or KMnO<sub>4</sub> as stoichiometric oxidants allowed the use of a wide range of nucleophiles, such as nitromethane, (aza)indoles, pyrroles, phenols, pyrazole, indazole and diethyl malonate. The formation of the target compounds presumably proceeds through a domino Knoevenagel/cyclization/Michael addition/oxidative cyclization reaction sequence.

## Introduction

Domino reactions are well recognized for their ability to effectively synthesize organic compounds, as far as creating two and more chemical bonds in one-step decreases waste, resources and time, and makes the development of methodology of synthesis in a domino fashion a substantial task [1]. Recently, much

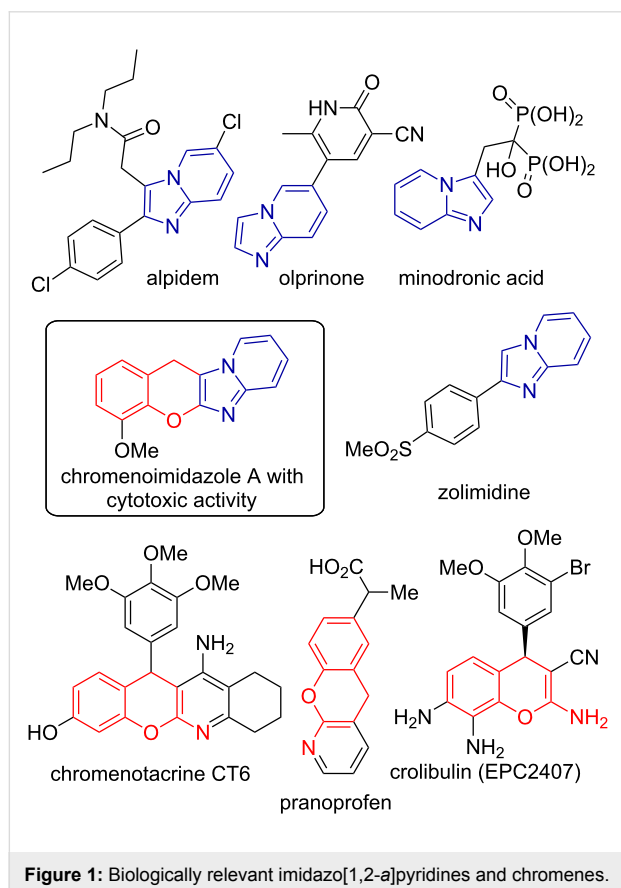
attention in research was given to domino reactions with an oxidation step, revealing possibilities for shifting the equilibrium by making products more stable or in situ generating reactive intermediates [2-13]. In its turn, multicomponent reactions (MCRs), usually occurring as domino processes with three or

more reactants mixed together, became a valuable tool for the synthetic chemistry to produce diverse and complex compounds in an efficient and sustainable way [14–17]. The use of oxidative conditions in MCRs was found to be useful [18], but challenging due to difficulty to match the redox potentials of three or more reactants at a time and employment of a sequential one-pot strategy may become one of the reasonable solutions.

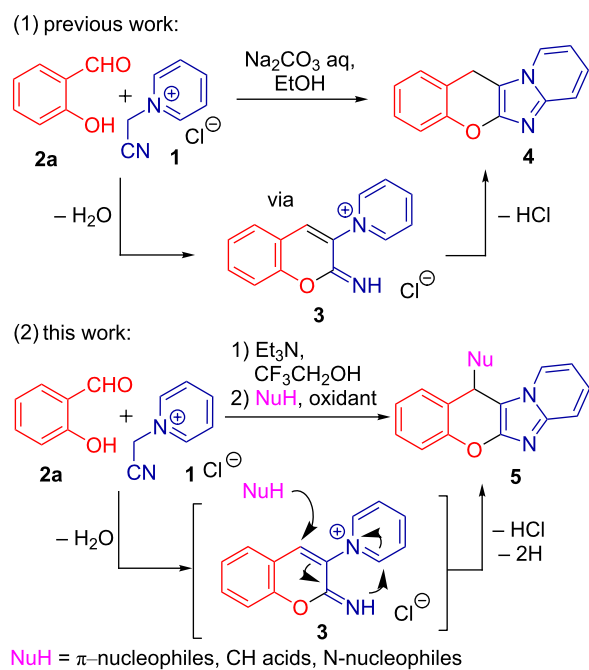
The vast biological activity of the compounds, bearing the imidazo[1,2-*a*]pyridine scaffold makes this heterocycle of great importance to the fields of medicinal chemistry and biology [19,20], illustrated by the marketed drugs, e.g., alpidem, minodronic acid, olprinone, zolimidine (Figure 1) and some recent examples of the imidazopyridines inhibiting tubulin polymerization [21], NF- $\kappa$ B [22], aldosterone synthase [23], or autotaxin [24]. Whereas many interesting approaches towards the imidazo[1,2-*a*]pyridine core are being published nowadays [25–30], this molecular entity is still a pursued synthetic target and novel routes to diverse imidazopyridines are of value. Another privileged scaffold for drug discovery is 2-aminochromene, which may be found in crolibulin, an antitumor agent, undergoing phase II clinical trials [31], chromenotacrine CT-6, a potential anti-Alzheimer agent [32], and pranoprofen, a

marketed anti-inflammatory drug [33]. Combination of chromene and imidazopyridine rings led to the discovery of compound **A** with promising anticancer activity [34], thereby showing the importance of this merged heterocyclic skeleton (Figure 1).

The formation of the chromene and imidazole rings in a single-step procedure was independently discovered by us [35,36] and Proença et al. [37,38], who identified 2-iminochromene **3** to be the key intermediate of the domino sequence (Scheme 1, reaction 1). Taking into account the capability of 2-iminochromenes to perform as Michael acceptors [39–41], we envisioned the diversification of the substitution pattern at the chromene ring to be a realizable and an appealing target, complicated by the need of an oxidant to fulfil the final aromatization. Following our interest in domino [42,43] and MCR chemistry [44,45] and taking an advantage of 2-iminochromene reactivity, herein we report a sequential three-component domino reaction of salicylaldehydes **2** and *N*-(cyanomethyl)pyridinium salts **1** with a broad scope of nucleophiles to produce diversely substituted valuable chromenoimidazopyridines under oxidative conditions (Scheme 1, reaction 2).



**Figure 1:** Biologically relevant imidazo[1,2-*a*]pyridines and chromenes.



**Scheme 1:** Domino formation of imidazopyridines and current work.

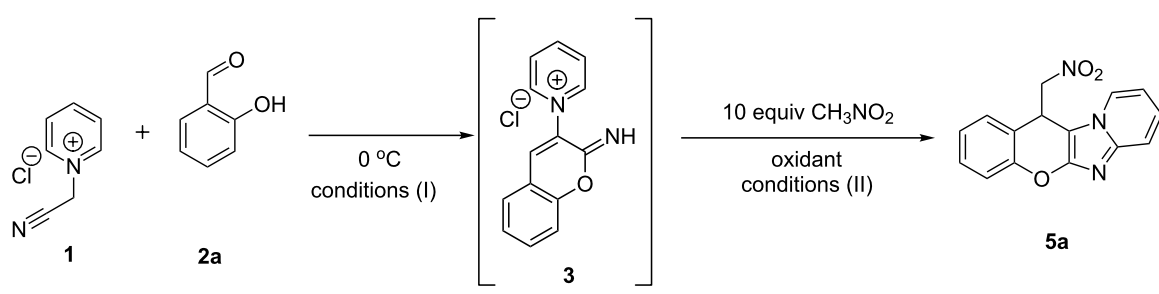
## Results and Discussion

To prove the designed concept, the reaction between salicylaldehyde (**2a**), *N*-(cyanomethyl)pyridinium chloride (**1**) and nitromethane as a nucleophile was carried out in ethanol with triethylamine as a base under air atmosphere in a two-step

fashion. Firstly, the quaternary salt was stirred with salicylaldehyde in the presence of triethylamine at 0 °C for 30 min, and secondly nitromethane (10 equiv) was added and the mixture was refluxed for 2 h in an open vessel. As a result, the desired product **5a** was isolated in trace amounts as a mixture with compound **4** (Table 1, entry 1). Performing the first step under cooling was found to be essential to avoid cyclization of 2-iminochromene intermediate **3** into the two-component reaction product **4**. It is worth noting, that the conversion of **3** to **4** is a constant side reaction, occurring even at rt and complicating the process. Since the air oxygen was not enough to deliver the needed cyclization, we started to look for an appropriate oxidant. The addition of 1.1 equiv diacetoxyiodobenzene (PIDA) as an external oxidant on the second step and changing the solvent to trifluoroethanol allowed the isolation of the desired product **5a** with 25% yield after 2 h reflux (Table 1,

entry 2), while leaving the reaction at rt for 7 days gave the compound **5a** with 30% yield (Table 1, entry 3). Further screening of the oxidants revealed, that the use of molecular iodine gave the desired product with 27% yield (Table 1, entry 4), while employment of NaOCl, NaIO<sub>4</sub>, MnO<sub>2</sub>, H<sub>2</sub>O<sub>2</sub>, or CuI/TBHP was not effective and led to the formation of complex mixtures (Table 1, entries 5–9), and use of CAN did not promote the reaction (Table 1, entry 10). The use of KMnO<sub>4</sub> which is known as a classical oxidant for pyridine amination [46], gave desired chromenoimidazopyridine **5a** with admissible 47% yield (Table 1, entry 11). The yield of 54% was achieved with Mn(OAc)<sub>3</sub>·2H<sub>2</sub>O (Table 1, entry 12), while increasing the reaction time of the first step gave product **5a** with good 64% yield (Table 1, entry 13). The use of EtOH as a solvent was found inappropriate, as the yield was decreased by 21% (Table 1, entry 14), and reducing the amount of nitro-

**Table 1:** Optimization of reaction conditions with nitromethane nucleophile.



entry	conditions (I)	oxidant (equiv)	conditions (II)	yield of <b>5a</b> (%)
1	Et <sub>3</sub> N (1 equiv), 0 °C, EtOH, 0.5 h	no oxidant	reflux, 2 h	traces
2	Et <sub>3</sub> N (1 equiv), 0 °C, TFE, 0.5 h	PIDA (1.1 equiv)	Et <sub>3</sub> N (2 equiv), reflux, 2 h	25
3	Et <sub>3</sub> N (1 equiv), 0 °C, TFE, 0.5 h	PIDA (1.1 equiv)	Et <sub>3</sub> N (2 equiv), rt, 7 days	30
4	Et <sub>3</sub> N (0.2 equiv), 0 °C, TFE, 1 h	I <sub>2</sub> (1 equiv)	Et <sub>3</sub> N (0.8 equiv), reflux, 1 h	27
5	Et <sub>3</sub> N (1 equiv), 0 °C, TFE, 0.5 h	NaOCl (5% aq, 3 equiv)	Et <sub>3</sub> N (1 equiv), reflux, 1 h	complex mixture
6	Et <sub>3</sub> N (1 equiv), 0 °C, TFE, 0.5 h	NaIO <sub>4</sub> (0.5 equiv)	Et <sub>3</sub> N (1 equiv), reflux, 1 h	complex mixture
7	Et <sub>3</sub> N (1 equiv), 0 °C, TFE, 0.5 h	MnO <sub>2</sub> (2 equiv)	Et <sub>3</sub> N (1 equiv), reflux, 1 h	complex mixture
8	Et <sub>3</sub> N (1 equiv), 0 °C, TFE, 0.5 h	33% aq H <sub>2</sub> O <sub>2</sub> (2 equiv)	Et <sub>3</sub> N (1 equiv), reflux, 1 h	complex mixture
9	Et <sub>3</sub> N (1 equiv), 0 °C, TFE, 0.5 h	CuI (0.1 equiv)/TBHP (2 equiv, 70% aq)	Et <sub>3</sub> N (1 equiv), reflux, 1 h	complex mixture
10	Et <sub>3</sub> N (1 equiv), 0 °C, TFE, 0.5 h	CAN (2 equiv)	Et <sub>3</sub> N (1 equiv), reflux, 1 h	–
11	Et <sub>3</sub> N (0.2 equiv), 0 °C, TFE, 1 h	KMnO <sub>4</sub> (1 equiv)	Et <sub>3</sub> N (0.8 equiv), reflux, 1 h	47
12	Et <sub>3</sub> N (1 equiv), 0 °C, TFE, 0.5 h	Mn(OAc) <sub>3</sub> ·2H <sub>2</sub> O (2 equiv)	Et <sub>3</sub> N (1 equiv), reflux, 1 h	54
13	Et <sub>3</sub> N (0.2 equiv), 0 °C, TFE, 1 h	Mn(OAc) <sub>3</sub> ·2H <sub>2</sub> O (2 equiv)	Et <sub>3</sub> N (1.8 equiv), reflux, 1 h	64
14	Et <sub>3</sub> N (0.2 equiv), 0 °C, EtOH dry, 1 h	Mn(OAc) <sub>3</sub> ·2H <sub>2</sub> O (2 equiv)	Et <sub>3</sub> N (1.8 equiv), reflux, 1 h	43
15 <sup>a</sup>	Et <sub>3</sub> N (0.2 equiv), 0 °C, TFE, 1 h	Mn(OAc) <sub>3</sub> ·2H <sub>2</sub> O (2 equiv)	Et <sub>3</sub> N (1.8 equiv), reflux, 1 h	59
16	DIPEA (0.2 equiv), 0 °C, TFE, 1 h	Mn(OAc) <sub>3</sub> ·2H <sub>2</sub> O (2 equiv)	DIPEA (1.8 equiv), reflux, 1 h	55
17	DABCO (0.2 equiv), 0 °C, TFE, 1 h	Mn(OAc) <sub>3</sub> ·2H <sub>2</sub> O (2 equiv)	DABCO (1.8 equiv), reflux, 1 h	42
18	K <sub>2</sub> CO <sub>3</sub> (0.2 equiv), 0 °C, TFE, 1 h	Mn(OAc) <sub>3</sub> ·2H <sub>2</sub> O (2 equiv)	K <sub>2</sub> CO <sub>3</sub> (1.8 equiv), reflux, 1 h	36
19	Et <sub>3</sub> N (0.2 equiv), 0 °C, TFE, 1 h	Mn(OAc) <sub>3</sub> ·2H <sub>2</sub> O (2 equiv)	Et <sub>3</sub> N (3.8 equiv), reflux, 1 h	64

<sup>a</sup>5 equiv CH<sub>3</sub>NO<sub>2</sub> was used instead of 10 equiv.

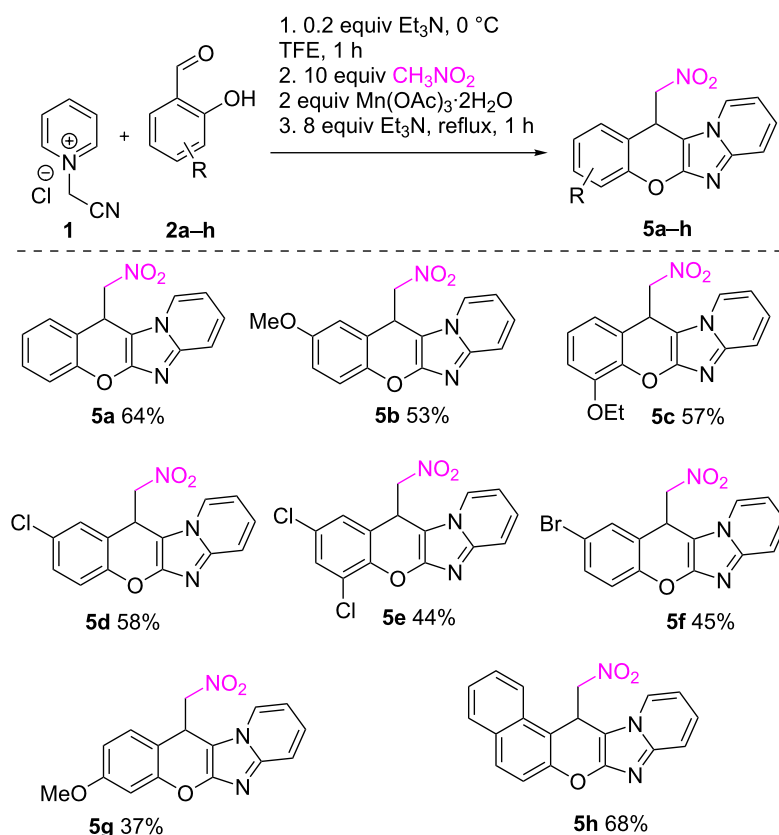
methane lowered the yield by 5% (Table 1, entry 15). Use of DIPEA (Table 1, entry 16), DABCO (Table 1, entry 17) or  $K_2CO_3$  (Table 1, entry 18) did not increase the yield of **5a**. Increasing the amount of  $Et_3N$  to 3.8 equiv at the second step allowed to suppress the formation of byproduct **22** (Scheme 6, reaction 2, **IV**) and simplified the isolation of **5a** (Table 1, entry 19, further referred to as optimal conditions), probably due to improved solubility of manganese salt.

To understand the scope of this three-component reaction of nitromethane, the optimized conditions were used with different *o*-hydroxybenzaldehydes to prepare products **5a–h** with 37–68% yields, displaying tolerance to diverse substitution patterns in the aldehyde component (Scheme 2).

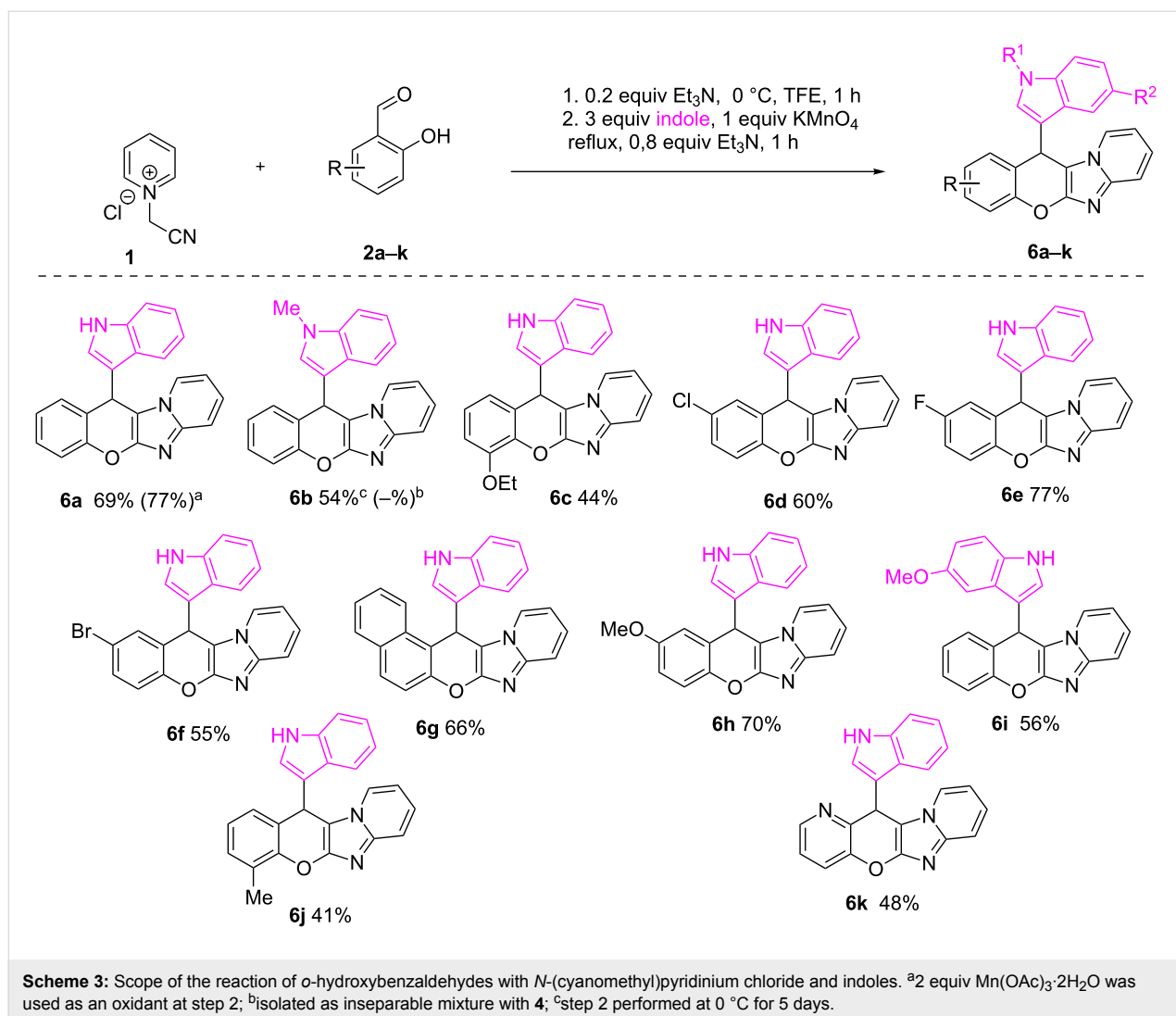
According to the literature [47–52], the introduction of an indole core into a chromene moiety is an appealing task, which prompted us to investigate the possibility to use this nucleophile in the discovered process. The previously optimized conditions worked nicely for the reaction of *N*-(cyanomethyl)pyridinium chloride, *o*-hydroxybenzaldehyde and indole, pro-

ducing the desired compound **6a** with good 77% yield (Scheme 3, footnote a). Unfortunately, the employment of *N*-methylindole resulted in the formation of the inseparable mixture of the target compound **6b** and the two-component reaction product **4** (Scheme 3, footnote b), showing the need for more general reaction conditions. It occurred that the use of  $KMnO_4$  as an oxidant was advantageous, though giving **6a** with a slightly lower yield of 69%, but furnishing *N*-methylindole product **6b** with 54% (Scheme 3, footnote c). Further investigation of the reaction scope gave rise to a series of diversely substituted chromenoimidazopyridines **6c–k**, demonstrating high synthetic potential of the transformation (Scheme 3).

To show the generality of the chosen oxidant, broad scope of nucleophiles was tested under selected conditions. Thus, employment of pyrrole as a nucleophile gave product **7a** in 43% yield, and *N*-methylpyrrole facilitated desired compound **7b** in 23% yield (Scheme 4). Isomeric 5-, 6- and 7-azaindoles were found to be appropriate nucleophiles too, producing the corresponding molecules **8–10**, in 60%, 53% and 49% yields, respectively.



**Scheme 2:** Scope of the reaction between *N*-(cyanomethyl)pyridinium chloride, *o*-hydroxybenzaldehydes, and nitromethane.

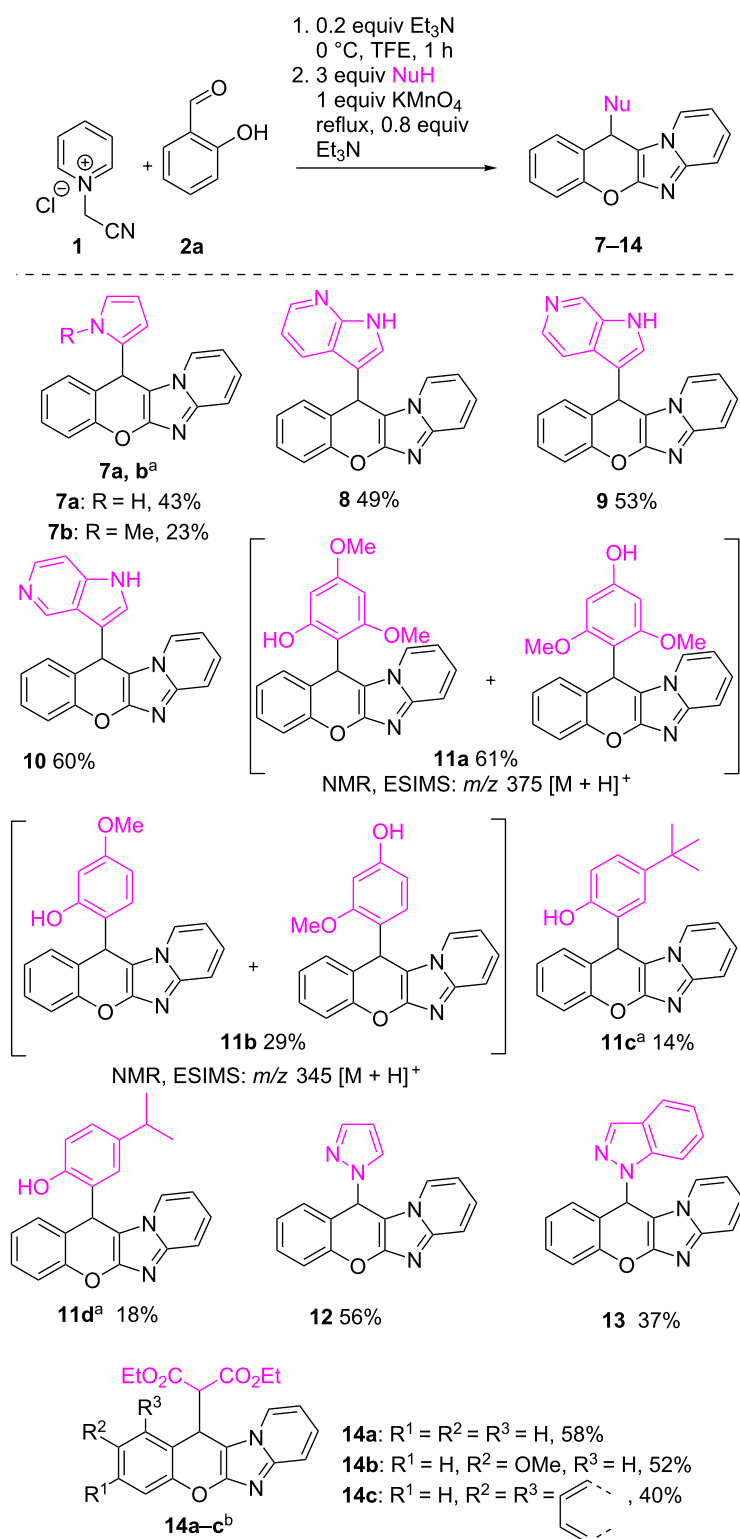


Such well-known  $\pi$ -nucleophiles as phenols could be used for the reaction, though 3-methoxyphenol and 3,5-dimethoxyphenol gave inseparable mixtures of regioisomers **11a** and **11b** (NMR, LCMS). The reactions with *p*-isopropyl- and *p*-*tert*-butylphenols gave only one isomer, but the yields of the corresponding products **11c** and **11d** were low. Employed as N-nucleophiles, pyrazole and benzopyrazole successfully formed products **12** and **13**, correspondingly, with moderate yields. The possibility to employ CH-acids as nucleophiles was finally demonstrated on diethyl malonate, providing compounds **14a–c** in 40–58% yields.

To conclusively reveal the scope of the reaction, we exploited *N*-cyanomethyl quaternary salts of fused thieno[2,3-*c*]pyridine **15** and 1-methyl-6-azaindole **16** in this transformation. Therefore, annulated chromenoimidazoles **17–20** were effectively produced in a sequential three-component manner (Scheme 5).

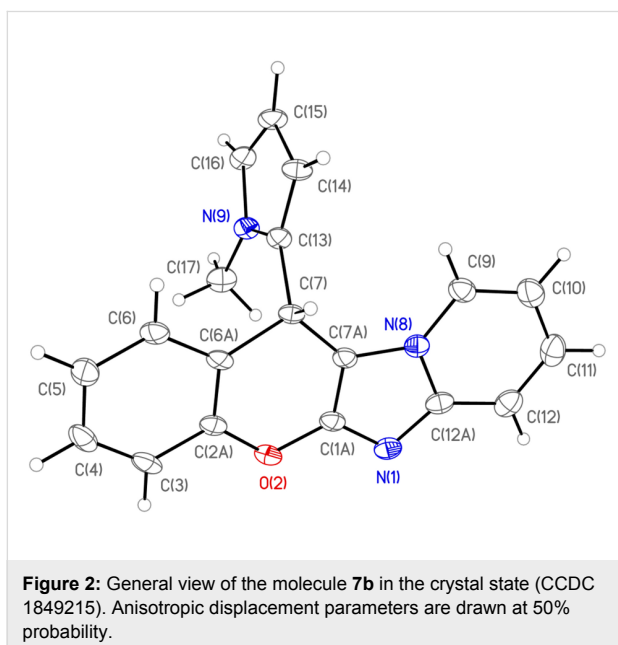
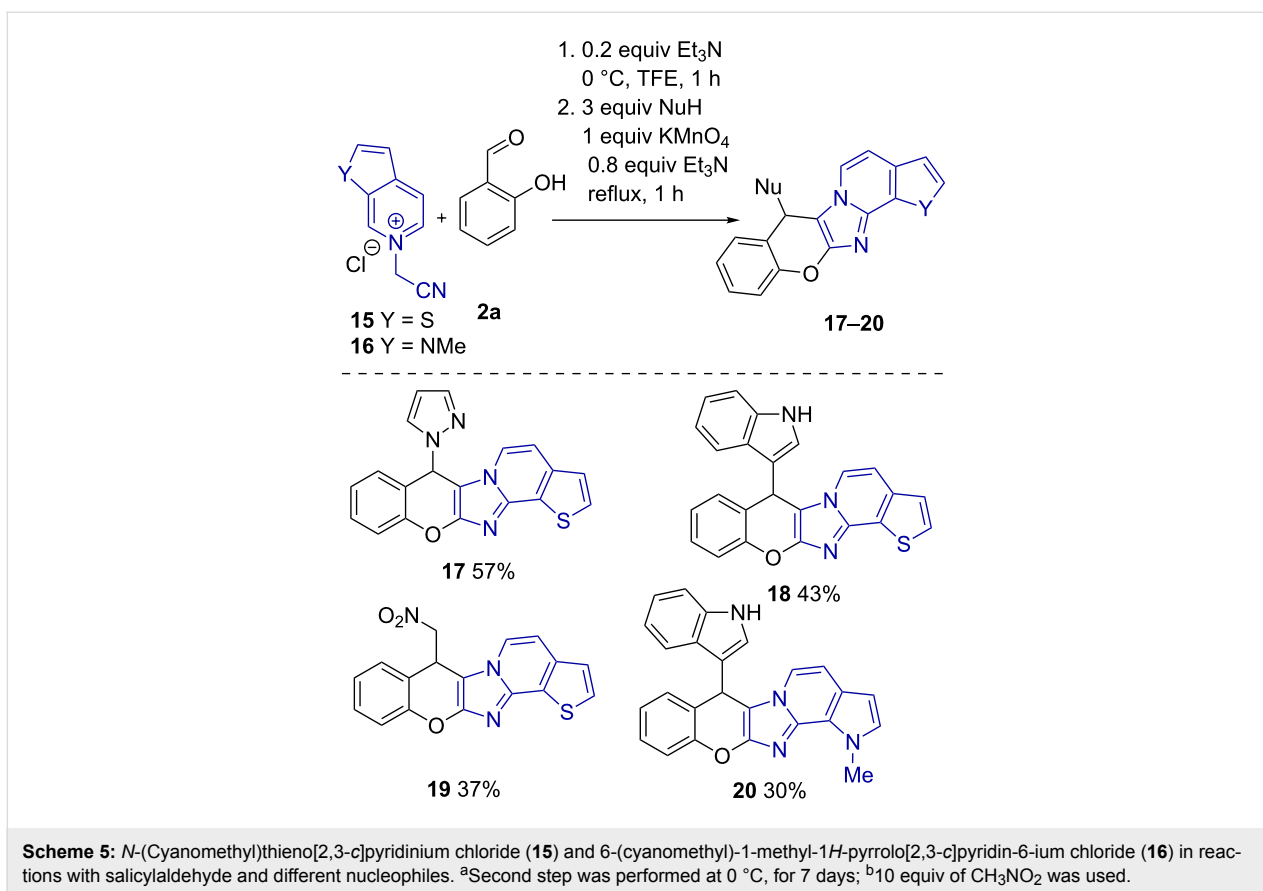
The structures of the synthesized compounds **5a–h**, **6a–k**, **7–14**, **17–20** were confirmed by <sup>1</sup>H, <sup>13</sup>C NMR, IR spectroscopy and HRMS spectra (see Supporting Information File 1 for details). The structure of the compound **7b** was unambiguously determined by a single crystal X-ray diffraction study (Figure 2).

The sequential domino reaction presumably starts with the Knoevenagel condensation of *o*-hydroxybenzaldehyde and *N*-(cyanomethyl)pyridinium salt forming styryl derivative **A**, which undergoes intramolecular cyclization to give 2-iminochromene salt **3**. Subsequent treatment of the reaction mixture with nucleophile, oxidant and a base leads to the Michael addition on C(4) of the chromene ring to produce 2-aminochromene **B** with incorporated nucleophilic moiety. Further cyclization and deprotonation furnishes anion **C**, which is easily oxidized to final product **5** (Scheme 6, reaction 1). The key 2-iminochromene intermediate **3** may be isolated as a perchlorate salt with 80% yield (Scheme 6, reaction 2). To confirm the reaction



**Scheme 4:** Scope of the nucleophiles in the reaction of *o*-hydroxyarylaldehydes with *N*-(cyanomethyl)pyridinium chloride and various nucleophiles.

<sup>a</sup>The second step was performed at 0 °C, for 5–8 days; <sup>b</sup>1 equiv EtO<sub>2</sub>CCH<sub>2</sub>CO<sub>2</sub>Et was used at the first step at 0 °C for 2 days, after which KMnO<sub>4</sub> was added and the reaction mixture was refluxed for 1 h.

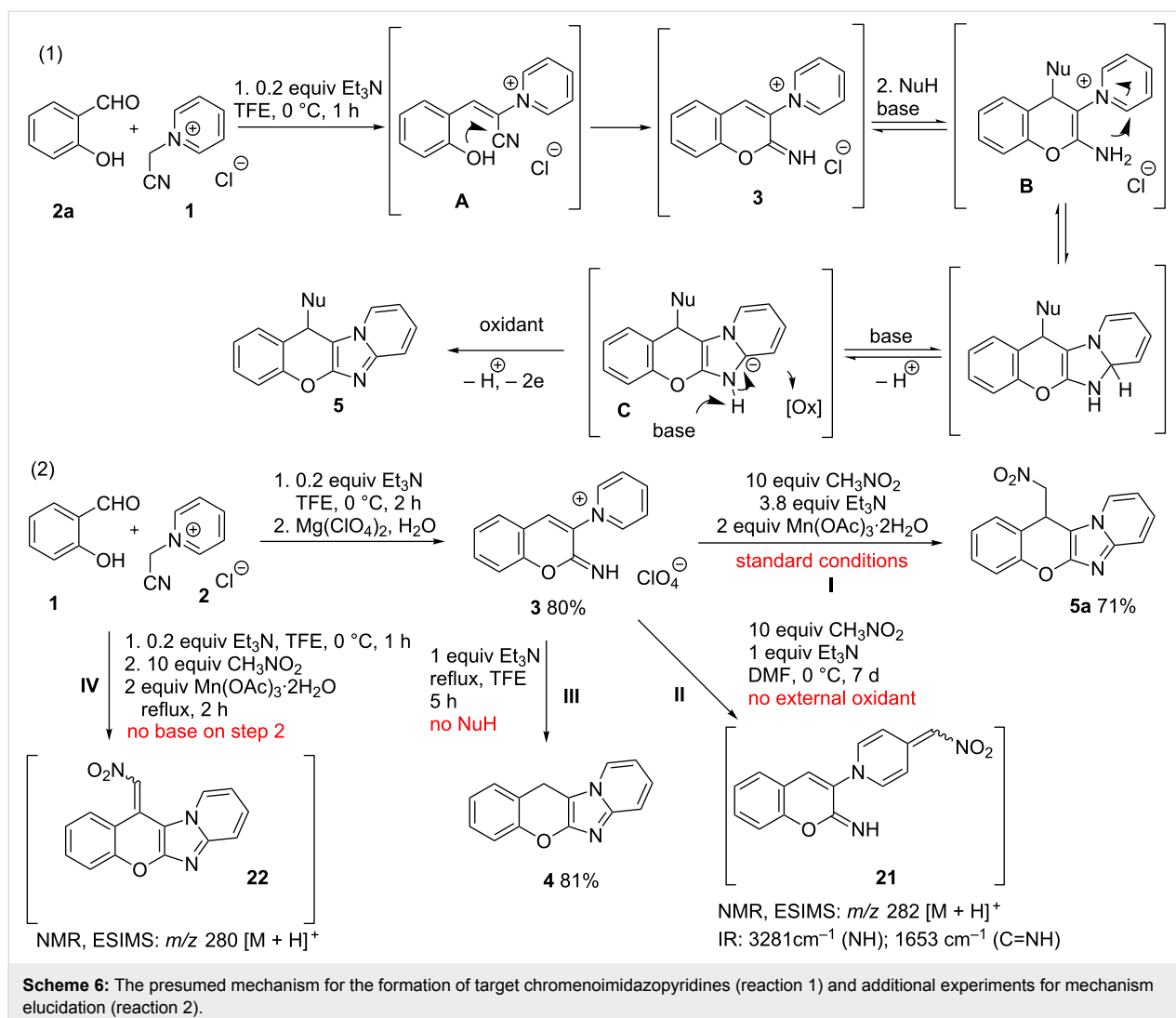


pathway, perchlorate **3** was converted into the product **5a** under the standard conditions with 71% yield (Scheme 6, reaction 2, **I**). Without an external oxidant, the reaction of perchlorate **3** with nitromethane fails to give the desired product, while com-

pound **21**, arisen from nucleophilic attack on pyridinium moiety, was the only isolated material (Scheme 6, reaction 2, **II**). Without a nucleophile, the perchlorate **3** was confidently converted into the product **4** with 81% yield (Scheme 6, reaction 2, **III**). The importance of the base on a second step of the transformation and its involvement in the oxidation part was affirmed experimentally. Thus, when the reaction was performed under the standard conditions, but no triethylamine was added at the second step, target product **5a** was not observed, and compound **22** was isolated in trace amounts. Its formation may be explained by an initial nucleophilic addition of water to intermediate chromene **3**, oxidation to keto-derivative and condensation with nitromethane (Scheme 6, reaction 2, **IV**).

## Conclusion

In conclusion, we have developed a practical route towards substituted chromenoimidazopyridines through a sequential three-component domino Knoevenagel/cyclization/Michael addition/oxidative cyclization reaction, employing cheap and abundant oxidants. The discovered process works in a broad substrate scope with special emphasis to the tolerance to a wide range of nucleophiles, despite high proximity of the nucleophilic and reductive properties. We presume the transformation finds its place in the diversity-oriented synthesis toolbox to



produce libraries of chromenoimidazoles with complex substitution and annulation patterns.

## Supporting Information

### Supporting Information File 1

Experimental part, copies of NMR spectra and X-ray diffraction data.

[<https://www.beilstein-journals.org/bjoc/content/supplementary/1860-5397-14-287-S1.pdf>]

## Acknowledgements

The publication was prepared with the support of the “RUDN University Program 5-100” and RFBR Grant 18-33-00536. A.A.F and L.G.V express sincere gratitude to Prof. Lutz F. Tietze for an inspirational meeting in the University of Göttingen.

## ORCID® iDs

Alexey A. Festa - <https://orcid.org/0000-0002-5113-1938>

Alexander V. Aksenov - <https://orcid.org/0000-0002-6644-9949>

Leonid G. Voskressensky - <https://orcid.org/0000-0002-9676-5846>

## References

- Tietze, L. F. *Domino Reactions: Concepts for Efficient Organic Synthesis*; Wiley-VCH, 2014; p 648. doi:10.1002/9783527671304
- Li, D.; Zeng, F. *Org. Lett.* **2017**, *19*, 6498–6501. doi:10.1021/acs.orglett.7b03164
- Men, Y.; Dong, J.; Wang, S.; Xu, X. *Org. Lett.* **2017**, *19*, 6712–6715. doi:10.1021/acs.orglett.7b03434
- Su, Z.; Gu, W.; Qian, S.; Xue, S.; Wang, C. *Eur. J. Org. Chem.* **2018**, 1019–1025. doi:10.1002/ejoc.201701674
- Furuta, M.; Hanaya, K.; Sugai, T.; Shoji, M. *Tetrahedron* **2017**, *73*, 2316–2322. doi:10.1016/j.tet.2017.03.021
- Li, Z.; Wu, S.-S.; Luo, Z.-G.; Liu, W.-K.; Feng, C.-T.; Ma, S.-T. *J. Org. Chem.* **2016**, *81*, 4386–4392. doi:10.1021/acs.joc.6b00569
- Liu, Y.; Hu, H.; Wang, X.; Zhi, S.; Kan, Y.; Wang, C. *J. Org. Chem.* **2017**, *82*, 4194–4202. doi:10.1021/acs.joc.7b00180

8. Tang, S.; Liu, K.; Long, Y.; Gao, X.; Gao, M.; Lei, A. *Org. Lett.* **2015**, *17*, 2404–2407. doi:10.1021/acs.orglett.5b00912
9. Wu, B.; Gao, X.; Yan, Z.; Chen, M.-W.; Zhou, Y.-G. *Org. Lett.* **2015**, *17*, 6134–6137. doi:10.1021/acs.orglett.5b03148
10. Lou, J.; Wang, Q.; Wu, K.; Wu, P.; Yu, Z. *Org. Lett.* **2017**, *19*, 3287–3290. doi:10.1021/acs.orglett.7b01431
11. Gebauer, K.; Reuß, F.; Spanka, M.; Schneider, C. *Org. Lett.* **2017**, *19*, 4588–4591. doi:10.1021/acs.orglett.7b02185
12. Yue, Y.; Zhang, Y.; Song, W.; Zhang, X.; Liu, J.; Zhuo, K. *Adv. Synth. Catal.* **2014**, *356*, 2459–2464. doi:10.1002/adsc.201400097
13. Pandey, K.; Rangan, K.; Kumar, A. *J. Org. Chem.* **2018**, *83*, 8026–8035. doi:10.1021/acs.joc.8b00884
14. Ibarra, I. A.; Islas-Jácome, A.; González-Zamora, E. *Org. Biomol. Chem.* **2018**, *16*, 1402–1418. doi:10.1039/c7ob02305g
15. Dömling, A.; Wang, W.; Wang, K. *Chem. Rev.* **2012**, *112*, 3083–3135. doi:10.1021/cr100233r
16. Volla, C. M. R.; Atodiresei, I.; Rueping, M. *Chem. Rev.* **2014**, *114*, 2390–2431. doi:10.1021/cr400215u
17. D'Souza, D. M.; Müller, T. J. J. *Chem. Soc. Rev.* **2007**, *36*, 1095–1108. doi:10.1039/b608235c
18. Moni, L.; Banfi, L.; Riva, R.; Basso, A. *Synthesis* **2016**, *48*, 4050–4059. doi:10.1055/s-0035-1562527
19. Deep, A.; Bhatia, R. K.; Kaur, R.; Kumar, S.; Jain, U. K.; Singh, H.; Batra, S.; Kaushik, D.; Deb, P. K. *Curr. Top. Med. Chem.* **2017**, *17*, 238–250. doi:10.2174/1568026616666160530153233
20. Goel, R.; Luxami, V.; Paul, K. *Curr. Top. Med. Chem.* **2016**, *16*, 3590–3616. doi:10.2174/1568026616666160414122644
21. Ramya, P. V. S.; Guntuku, L.; Angapelly, S.; Digwal, C. S.; Lakshmi, U. J.; Sigalapalli, D. K.; Babu, B. N.; Naidu, V. G. M.; Kamal, A. *Eur. J. Med. Chem.* **2018**, *143*, 216–231. doi:10.1016/j.ejmech.2017.11.010
22. Vasu, K. K.; Digwal, C. S.; Pandya, A. N.; Pandya, D. H.; Sharma, J. A.; Patel, S.; Agarwal, M. *Bioorg. Med. Chem. Lett.* **2017**, *27*, 5463–5466. doi:10.1016/j.bmcl.2017.10.060
23. Whitehead, B. R.; Lo, M. M.-C.; Ali, A.; Park, M. K.; Hoyt, S. B.; Xiong, Y.; Cai, J.; Carswell, E.; Cooke, A.; MacLean, J.; Ratcliffe, P.; Robison, J.; Bennett, D. J.; Clemas, J. A.; Wisniewski, T.; Struthers, M.; Cully, D.; MacNeil, D. J. *Bioorg. Med. Chem. Lett.* **2017**, *27*, 143–146. doi:10.1016/j.bmcl.2016.12.003
24. Desroy, N.; Housseman, C.; Bock, X.; Joncour, A.; Bienvenu, N.; Cherel, L.; Labeguere, V.; Rondet, E.; Peixoto, C.; Grassot, J.-M.; Picolet, O.; Annot, D.; Triballeau, N.; Monjardet, A.; Wakselman, E.; Roncoroni, V.; Le Tallec, S.; Blaque, R.; Cottreaux, C.; Vandervoort, N.; Christophe, T.; Mollat, P.; Lamers, M.; Auberval, M.; Hrvacic, B.; Ralic, J.; Oste, L.; van der Aar, E.; Brys, R.; Heckmann, B. *J. Med. Chem.* **2017**, *60*, 3580–3590. doi:10.1021/acs.jmedchem.7b00032
25. Pericherla, K.; Kaswan, P.; Pandey, K.; Kumar, A. *Synthesis* **2015**, *47*, 887–912. doi:10.1055/s-0034-1380182
26. Bagdi, A. K.; Santra, S.; Monir, K.; Hajra, A. *Chem. Commun.* **2015**, *51*, 1555–1575. doi:10.1039/c4cc08495k
27. Ravi, C.; Adimurthy, S. *Chem. Rec.* **2017**, *17*, 1019–1038. doi:10.1002/tcr.201600146
28. Pandey, K.; Kaswan, P.; Saroy, Kumar, A. *ChemistrySelect* **2016**, *1*, 6669–6672. doi:10.1002/slct.201601294
29. Balalaie, S.; Derakhshan-Panah, F.; Zolfigol, M. A.; Rominger, F. *Synlett* **2018**, *29*, 89–93. doi:10.1055/s-0036-1590906
30. Guo, P.; Huang, S.; Mo, J.; Chen, X.; Jiang, H.; Chen, W.; Cai, H.; Zhan, H. *Catal. Commun.* **2017**, *90*, 43–46. doi:10.1016/j.catcom.2016.10.033
31. Cai, S. X.; Drewe, J.; Kemnitzer, W. *Anti-Cancer Agents Med. Chem.* **2009**, *9*, 437–456. doi:10.2174/1871520610909040437
32. Akyol-Salman, İ.; Leçe-Sertöz, D.; Baykal, O. *J. Ocul. Pharmacol. Ther.* **2007**, *23*, 280–283. doi:10.1089/jop.2006.108
33. Oset-Gasque, M. J.; González, M. P.; Pérez-Peña, J.; García-Font, N.; Romero, A.; del Pino, J.; Ramos, E.; Hadjipavlou-Litina, D.; Soriano, E.; Chioua, M.; Samadi, A.; Raghuvanshi, D. S.; Singh, K. N.; Marco-Contelles, J. *Eur. J. Med. Chem.* **2014**, *74*, 491–501. doi:10.1016/j.ejmech.2013.12.021
34. Lima, C. F.; Costa, M.; Proença, M. F.; Pereira-Wilson, C. *Eur. J. Pharm. Sci.* **2015**, *72*, 34–45. doi:10.1016/j.ejps.2015.02.019
35. Safarov, S.; Voskressensky, L. G.; Bizhko, O. V.; Kulikova, L. N.; Khurstalev, V. N. *Acta Crystallogr., Sect. E: Struct. Rep. Online* **2010**, *66*, o710. doi:10.1107/s1600536810006744
36. Voskressensky, L. G.; Kulikova, L. N.; Listratova, A. V.; Borisov, R. S.; Kukaniev, M. A.; Varlamov, A. V. *Tetrahedron Lett.* **2010**, *51*, 2269–2270. doi:10.1016/j.tetlet.2010.02.102
37. Proença, M. F.; Costa, M. *Tetrahedron* **2010**, *66*, 4542–4550. doi:10.1016/j.tet.2010.04.059
38. Costa, M.; Proença, M. F. *Tetrahedron* **2011**, *67*, 8622–8627. doi:10.1016/j.tet.2011.09.054
39. Yang, G.; Luo, C.; Mu, X.; Wang, T.; Liu, X.-Y. *Chem. Commun.* **2012**, *48*, 5880. doi:10.1039/c2cc30731f
40. Li, W.; Huang, J.; Wang, J. *Org. Biomol. Chem.* **2013**, *11*, 400–406. doi:10.1039/c2ob27102h
41. Koz, G.; Koz, Ö. *Z. Naturforsch., B: J. Chem. Sci.* **2017**, *72*, 647–653. doi:10.1515/znb-2017-0040
42. Voskressensky, L. G.; Festa, A. A.; Storozhenko, O. A.; Le, T. A.; Nguyen, V. T.; Varlamov, A. V. *RSC Adv.* **2015**, *5*, 12442–12445. doi:10.1039/c4ra14122a
43. Voskressensky, L. G.; Storozhenko, O. A.; Festa, A. A.; Novikov, R. A.; Varlamov, A. V. *Synthesis* **2017**, *49*, 2753–2760. doi:10.1055/s-0036-1589496
44. Golantsov, N. E.; Nguyen, H. M.; Varlamov, A. V.; Aksenov, A. V.; Voskressensky, L. G. *Chem. Heterocycl. Compd.* **2017**, *53*, 446–450. doi:10.1007/s10593-017-2073-1
45. Festa, A. A.; Storozhenko, O. A.; Bella Ndoutoume, D. R.; Varlamov, A. V.; Voskressensky, L. G. *Mendeleev Commun.* **2017**, *27*, 451–453. doi:10.1016/j.mencom.2017.09.006
46. Gulevskaya, A. V.; Pozharskii, A. F. *The S N H -Amination of Heteroaromatic Compounds. Metal Free C-H Functionalization of Aromatics*; Topics in Heterocyclic Chemistry; Springer International Publishing: Cham, Switzerland, 2013; pp 179–239. doi:10.1007/7081\_2013\_114
47. Ye, M.-C.; Yang, Y.-Y.; Tang, Y.; Sun, X.-L.; Ma, Z.; Qin, W.-M. *Synlett* **2006**, 1240–1244. doi:10.1055/s-2006-932472
48. Chen, W.; Cai, Y.; Fu, X.; Liu, X.; Lin, L.; Feng, X. *Org. Lett.* **2011**, *13*, 4910–4913. doi:10.1021/ol2019949
49. Nickerson, D. M.; Mattson, A. E. *Chem. – Eur. J.* **2012**, *18*, 8310–8314. doi:10.1002/chem.201201206
50. Gao, Y.; Du, D.-M. *Tetrahedron: Asymmetry* **2013**, *24*, 1312–1317. doi:10.1016/j.tetasy.2013.08.018
51. Desyatkin, V. G.; Beletskaya, I. P. *Synthesis* **2017**, *49*, 4327–4334. doi:10.1055/s-0036-1589024
52. Feofanov, M. N.; Anokhin, M. V.; Averin, A. D.; Beletskaya, I. P. *Synthesis* **2017**, *49*, 5045–5058. doi:10.1055/s-0036-1589068

## License and Terms

This is an Open Access article under the terms of the Creative Commons Attribution License (<http://creativecommons.org/licenses/by/4.0>). Please note that the reuse, redistribution and reproduction in particular requires that the authors and source are credited.

The license is subject to the *Beilstein Journal of Organic Chemistry* terms and conditions: (<https://www.beilstein-journals.org/bjoc>)

The definitive version of this article is the electronic one which can be found at:  
[doi:10.3762/bjoc.14.287](https://doi.org/10.3762/bjoc.14.287)



# Microwave-assisted synthesis of *N,N*-bis(phosphinoylmethyl)amines and *N,N,N*-tris(phosphinoylmethyl)amines bearing different substituents on the phosphorus atoms

Erika Bálint\*, Anna Tripolszky, László Hegedűs and György Keglevich

## Full Research Paper

Open Access

Address:  
Department of Organic Chemistry and Technology, Budapest  
University of Technology and Economics, 1521 Budapest, Hungary

Email:  
Erika Bálint\* - ebalint@mail.bme.hu

\* Corresponding author

Keywords:  
(aminomethyl)phosphine oxides; Kabachnik–Fields reaction; ligand;  
microwave; *N,N*-bis(phosphinoylmethyl)amines;  
*N,N,N*-tris(phosphinoylmethyl)amines

*Beilstein J. Org. Chem.* **2019**, *15*, 469–473.  
doi:10.3762/bjoc.15.40

Received: 03 December 2018  
Accepted: 30 January 2019  
Published: 15 February 2019

This article is part of the thematic issue "Multicomponent reactions III".

Guest Editor: T. J. J. Müller

© 2019 Bálint et al.; licensee Beilstein-Institut.  
License and terms: see end of document.

## Abstract

A family of *N,N*-bis(phosphinoylmethyl)amines bearing different substituents on the phosphorus atoms was synthesized by the microwave-assisted and catalyst-free Kabachnik–Fields reaction of (aminomethyl)phosphine oxides with paraformaldehyde and diphenylphosphine oxide. The three-component condensation of *N,N*-bis(phosphinoylmethyl)amine, paraformaldehyde and a secondary phosphine oxide affording *N,N,N*-tris(phosphinoylmethyl)amine derivatives was also elaborated. This method is a novel approach for the synthesis of the target products.

## Introduction

$\alpha$ -Aminophosphine oxides are of considerable importance as potential precursors of  $\alpha$ -aminophosphine ligands [1].  $\alpha$ -Aminophosphines play an important role in the synthesis of P(III)-transition metal complexes [2], which are often applied catalysts in homogeneous catalytic reactions [2-4]. In addition, a few Pt, Ru and Au complexes incorporating phosphine ligands show significant anticancer activity [5,6].

One of the most common synthetic routes to  $\alpha$ -aminophosphine oxides is the Kabachnik–Fields (phospha-Mannich) reaction, where an amine, an oxo compound (aldehyde or ketone) and a secondary phosphine oxide react in a condensation reaction [1]. However, only a few papers deal with the synthesis of

$\alpha$ -aminophosphine oxides. (Phenylaminomethyl)dibenzylphosphine oxide was prepared by the three-component reaction of aniline, paraformaldehyde and dibenzylphosphine oxide [7], as well as by the reaction of (hydroxymethyl)dibenzylphosphine oxide and aniline [8]. The condensation of butylamine, paraformaldehyde and di(*p*-tolyl)phosphine oxide to afford (butylaminomethyl)di(*p*-tolyl)phosphine oxide was also described [9]. A microwave (MW)-assisted, catalyst-free method was elaborated by us for the synthesis of several (aminomethyl)phosphine oxides [10,11].

As regards  $\alpha$ -aminophosphine oxides with different P-substituents, only two different types were reported. Olszewski and

co-workers synthesized chiral thiazole-substituted aminophosphine oxides **2** through the Pudovik reaction of alkylphenylphosphine oxides and the corresponding aldimine derivatives of thiazole **1** (Scheme 1) [12].

Cherkasov and his group applied the Kabachnik–Fields reaction to synthesize a P-chiral aminophosphine oxide with a 2-pyridyl substituent **3** (Scheme 2) [13].

Bis(aminophosphine oxide) derivatives were also prepared by the double Kabachnik–Fields reaction using primary amines [11,14,15], amino acids [16,17] or aminoethanol [14] as the amine component.

To the best of our knowledge, only one example can be found for a bis( $\alpha$ -aminophosphine oxide) containing different P-functions that was prepared by the condensation of (octylaminomethyl)dihexylphosphine oxide, paraformaldehyde and di(*p*-tolyl)phosphine oxide in the presence of *p*-toluenesulfonic acid in boiling acetonitrile (Scheme 3) [12].

Furthermore, tris( $\alpha$ -aminophosphine oxide) derivatives have not been described in the literature up to now. In this paper, we report the efficient, catalyst-free and MW-assisted synthesis of

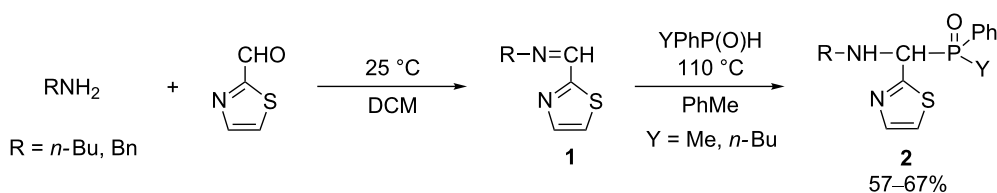
*N,N*-bis(phosphinoylmethyl)amine and *N,N,N*-tris(phosphinoylmethyl)amine derivatives bearing different substituents on the phosphorus atoms.

## Results and Discussion

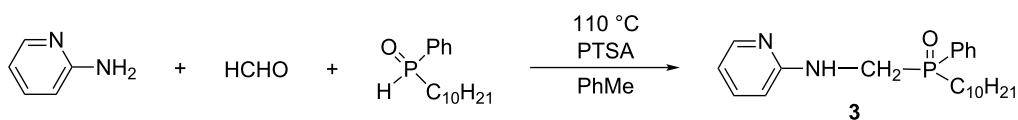
### Synthesis of *N,N*-bis(phosphinoylmethyl)alkylamines containing different substituents on the phosphorus atoms

First, the (aminomethyl)phosphine oxide starting materials **5–7** were synthesized following our previous protocol [11]. Thus, the MW-assisted Kabachnik–Fields reaction of primary amines (butyl-, cyclohexyl- or benzylamine), paraformaldehyde and di(*p*-tolyl)- or dibenzylphosphine oxide was carried out in acetonitrile at 100 °C for 1 h affording the products with excellent yields (Scheme 4).

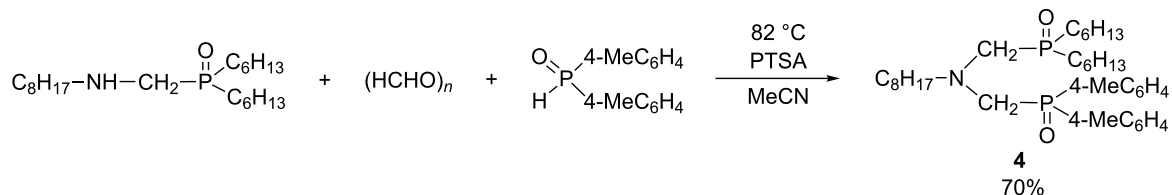
Then, (aminomethyl)diphenylphosphine oxide (**9**) was prepared through debenzylation of (benzylaminomethyl)diphenylphosphine oxide (**8**, Scheme 5). The reduction was carried out in the presence of a 10% palladium on carbon catalyst (Selcat Q), in methanol, at 75 °C for 3 h, and the (aminomethyl)diphenylphosphine oxide (**9**) was obtained in a yield of 47% after column chromatography.



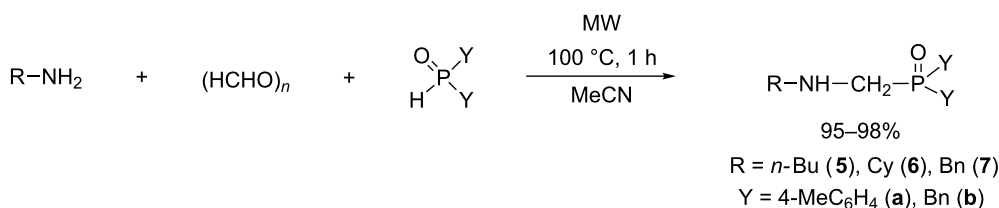
**Scheme 1:** Synthesis of chiral thiazole-substituted aminophosphine oxides.



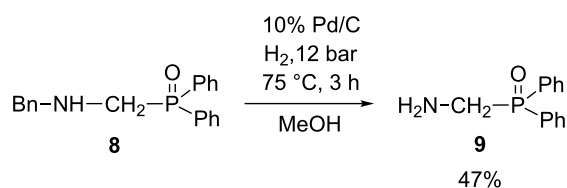
**Scheme 2:** Synthesis of a P-chiral aminophosphine oxide containing a 2-pyridyl moiety.



**Scheme 3:** Condensation of (octylaminomethyl)dihexylphosphine oxide with paraformaldehyde and di(*p*-tolyl)phosphine oxide.



Scheme 4: Synthesis of (aminomethyl)phosphine oxides 5–7.

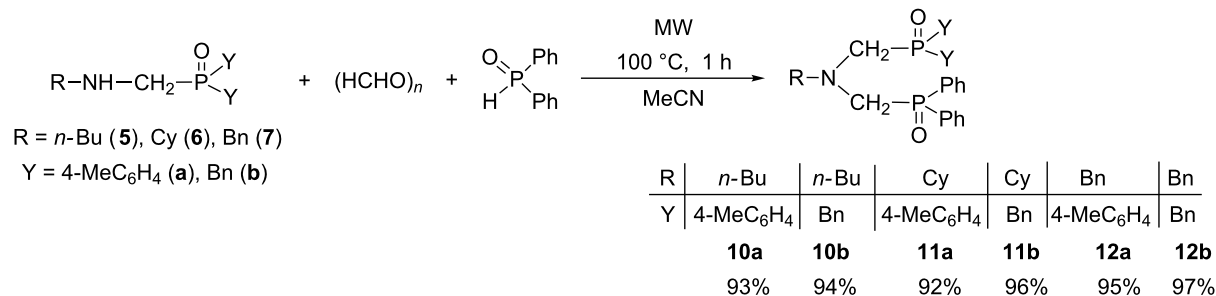
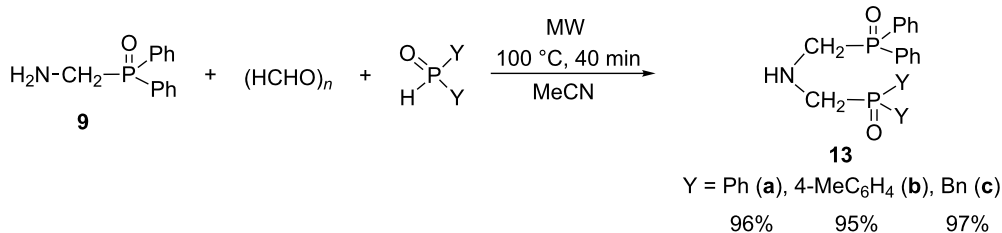


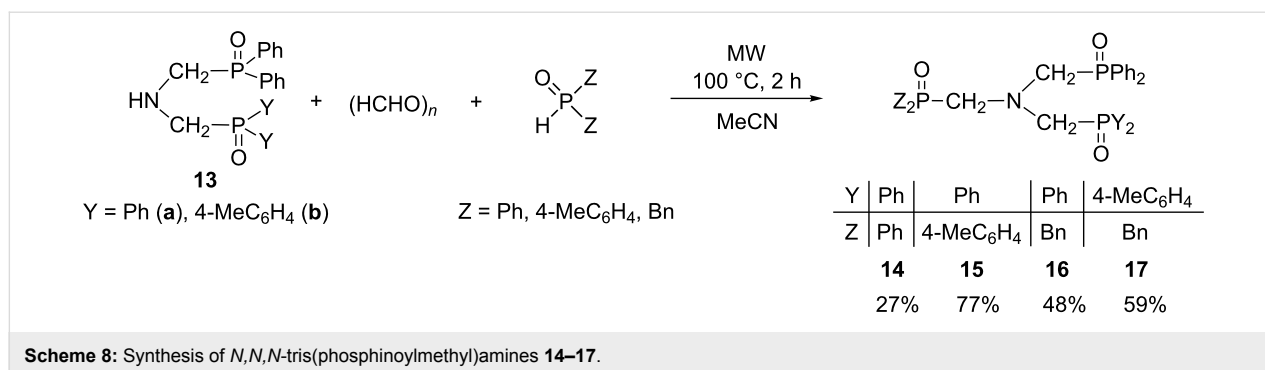
Scheme 5: Synthesis of (aminomethyl)diphenylphosphine oxide (9).

In the next step, (aminomethyl)phosphine oxides **5–7** were converted to bis(phosphinoylmethyl)amine derivatives bearing different substituents at the phosphorous atoms (Y<sub>2</sub>P=O) by reacting them with one equivalent of paraformaldehyde and diphenylphosphine oxide under MW conditions (Scheme 6). The three-component condensations were performed in the absence of any catalyst in acetonitrile as the solvent to over-

come the heterogeneity of the reaction mixture. After an irradiation of 1 h at 100 °C, the mixed *N,N*-bis(phosphinoylmethyl)amines **10a,b**, **11a,b** and **12a,b** were obtained in yields of 92–97% and their structures were confirmed by <sup>31</sup>P, <sup>13</sup>C and <sup>1</sup>H NMR, as well as HRMS measurements. Due to the two differently substituted phosphorous nuclei in the molecules, two signals were observed in the <sup>31</sup>P NMR spectra.

The valuable intermediate **9** was then utilized in the synthesis of *N,N*-bis(phosphinoylmethyl)amines **13a–c** (Scheme 7). The condensation of (aminomethyl)diphenylphosphine oxide (**9**), paraformaldehyde and various secondary phosphine oxides, such as diphenyl, di(*p*-tolyl) or dibenzylphosphine oxide, at 100 °C for 40 min led to the corresponding *N,N*-bis(phosphinoylmethyl)amines containing identical (**13a**) or different substituents on the phosphorus atoms (**13b** and **13c**) in excellent yields (95–97%).

Scheme 6: Synthesis of *N,N*-bis(phosphinoylmethyl)amines **10a,b**, **11a,b** and **12a,b** bearing different substituents at the phosphorus atoms (Y<sub>2</sub>P=O).Scheme 7: Synthesis of *N,N*-bis(phosphinoylmethyl)amines **13a–c**.



## Synthesis of *N,N,N*-tris(phosphinoylmethyl)amines

Finally, *N,N*-bis(phosphinoylmethyl)amines **13a** and **13b** were reacted further with paraformaldehyde and a secondary phosphine oxide (diphenyl-, di(*p*-tolyl)- or dibenzylphosphine oxide) to afford the *N,N,N*-tris(phosphinoylmethyl)amine derivatives bearing identical (**14**) and different Y<sub>2</sub>P=O groups (**15–17**) (Scheme 8). The condensations were performed as mentioned above. The introduction of a third phosphinoylmethyl moiety into the bis-derivatives containing an NH unit (**13a** and **13b**) required a longer reaction time (2 h) at 100 °C. In these cases, the conversion was 70–95%, and the corresponding *N,N,N*-tris(phosphinoylmethyl)amine derivatives **14–17** were isolated in yields of 27–77%. However, applying a higher temperature and/or longer reaction time, lead to decomposition.

## Conclusion

In summary, we have developed an efficient, catalyst-free and MW-assisted method for the synthesis of *N,N*-bis(phosphinoylmethyl)amines and *N,N,N*-tris(phosphinoylmethyl)amines bearing different substituents on the phosphorus atoms by the Kabachnik–Fields reaction. This method is a novel approach for the synthesis of the target products. In all, thirteen new derivatives were isolated in high yields and fully characterized.

## Supporting Information

### Supporting Information File 1

Experimental procedures, characterization data, details of the NMR structural determination of all products and copies of <sup>31</sup>P, <sup>1</sup>H, and <sup>13</sup>C NMR spectra for all compounds synthesized.

[<https://www.beilstein-journals.org/bjoc/content/supplementary/1860-5397-15-40-S1.pdf>]

## Acknowledgements

The above project was supported by the Hungarian Research Development and Innovation Fund (FK123961 and K119202),

and in part (E. B.) by the János Bolyai Research Scholarship of the Hungarian Academy of Sciences (BO/00278/17/7) and by the ÚNKP-18-4-BME-131 New National Excellence Program of the Ministry of Human Capacities. The authors thank for Zoltán Márta to the HRMS measurements.

## ORCID® IDs

Erika Bálint - <https://orcid.org/0000-0002-5107-7089>

Anna Tripolszky - <https://orcid.org/0000-0002-3223-7315>

László Hegedűs - <https://orcid.org/0000-0002-7980-0443>

György Keglevich - <https://orcid.org/0000-0002-5366-472X>

## References

- Goud, E. V.; Sivaramakrishna, A.; Vijayakrishna, K. *Top. Curr. Chem.* **2017**, *375*, 10. doi:10.1007/s41061-016-0090-7
- Bálint, E.; Tajti, Á.; Tripolszky, A.; Keglevich, G. *Dalton Trans.* **2018**, *47*, 4755–4778. doi:10.1039/c8dt00178b
- Tsujii, J. *Transition Metal Reagents and Catalysts*; Wiley: Chichester, 2002. doi:10.1002/0470854766
- Beller, M.; Bolm, C. *Transition Metals for Organic Synthesis: Building Blocks and Fine Chemicals*; Wiley: Weinheim, 2004. doi:10.1002/9783527619405
- Berners-Price, S. J.; Sadler, P. J. Phosphines and metal phosphine complexes: Relationship of chemistry to anticancer and other biological activity. *Bioinorganic Chemistry. Structure and Bonding*; Springer: Berlin, Heidelberg, Germany, 1988; Vol. 70, pp 27–102. doi:10.1007/3-540-50130-4\_2
- Nazarov, A. A.; Dyson, P. J. Metal Phosphorus Complexes as Antitumor Agents. In *Phosphorus Compounds*; Luca, G.; Peruzzini, M., Eds.; Springer: Dordrecht, Netherlands, 2011; Vol. 37, pp 445–461. doi:10.1007/978-90-481-3817-3\_13
- Petrov, K. A.; Chauzov, V. A.; Erokhina, T. S.; Chernobrovkina, L. P. *Zh. Obshch. Khim.* **1976**, *46*, 493.
- Petrov, K. A.; Chauzov, V. A.; Erokhina, T. S. *Khim. Elementoorg. Soedin.* **1976**, 200.
- Garifzyanov, A. R.; Vasil'ev, R. I.; Cherkasov, R. A. *Russ. J. Gen. Chem.* **2005**, *75*, 217–224. doi:10.1007/s11176-005-0201-6
- Keglevich, G.; Szekrényi, A. *Lett. Org. Chem.* **2008**, *5*, 616–622. doi:10.2174/157017808786857598
- Bálint, E.; Tripolszky, A.; Jablonkai, E.; Karaghiosoff, K.; Czugler, M.; Mucsi, Z.; Kollár, L.; Pongrácz, P.; Keglevich, G. *J. Organomet. Chem.* **2016**, *801*, 111–121. doi:10.1016/j.jorganchem.2015.10.029

12. Olszewski, T. K.; Boduszek, B.; Sobek, S.; Kozłowski, H. *Tetrahedron* **2006**, *62*, 2183–2189. doi:10.1016/j.tet.2005.12.016
13. Cherkasov, R. A.; Garifzyanov, A. R.; Koshkin, S. A. *Russ. J. Gen. Chem.* **2011**, *81*, 773–774. doi:10.1134/s107036321104027x
14. Cherkasov, R. A.; Garifzyanov, A. R.; Talan, A. S.; Davletshin, R. R.; Kurmosova, N. V. *Russ. J. Gen. Chem.* **2009**, *79*, 1835–1849. doi:10.1134/s1070363209090114
15. Bálint, E.; Fazekas, E.; Pongrácz, P.; Kollár, L.; Drahos, L.; Holczbauer, T.; Czugler, M.; Keglevich, G. *J. Organomet. Chem.* **2012**, *717*, 75–82. doi:10.1016/j.jorganchem.2012.07.031
16. Bálint, E.; Fazekas, E.; Kóti, J.; Keglevich, G. *Heteroat. Chem.* **2015**, *26*, 106–115. doi:10.1002/hc.21221
17. Zefirov, N. S.; Matveeva, E. D. *ARKIVOC* **2008**, No. i, 1–17. doi:10.3998/ark.5550190.0009.101

## License and Terms

This is an Open Access article under the terms of the Creative Commons Attribution License (<http://creativecommons.org/licenses/by/4.0>). Please note that the reuse, redistribution and reproduction in particular requires that the authors and source are credited.

The license is subject to the *Beilstein Journal of Organic Chemistry* terms and conditions: (<https://www.beilstein-journals.org/bjoc>)

The definitive version of this article is the electronic one which can be found at:  
[doi:10.3762/bjoc.15.40](https://doi.org/10.3762/bjoc.15.40)



## Design of indole- and MCR-based macrocycles as p53-MDM2 antagonists

Constantinos G. Neochoritis<sup>1</sup>, Maryam Kazemi Miraki<sup>2</sup>, Eman M. M. Abdelraheem<sup>1</sup>, Ewa Surmiak<sup>3</sup>, Tryfon Zarganes-Tzitzikas<sup>1</sup>, Beata Łabuzek<sup>3</sup>, Tad A. Holak<sup>3</sup> and Alexander Dömling<sup>\*1</sup>

### Full Research Paper

[Open Access](#)**Address:**

<sup>1</sup>Department of Drug Design, University of Groningen, Antonius Deusinglaan 1, 9700 AD Groningen, The Netherlands, <sup>2</sup>Chemistry Department, Tarbiat Modares University, P.O. Box 14155-4838, Tehran, Iran and <sup>3</sup>Faculty of Chemistry, Jagiellonian University, Gronostajowa 2, 30-387 Krakow, Poland

**Email:**

Alexander Dömling\* - a.s.s.domling@rug.nl

\* Corresponding author

**Keywords:**

<sup>1</sup>H, <sup>15</sup>N HSQC NMR; indole; macrocycles; multicomponent; p53-MDM2; Ugi reaction

*Beilstein J. Org. Chem.* **2019**, *15*, 513–520.

doi:10.3762/bjoc.15.45

Received: 25 October 2018

Accepted: 14 February 2019

Published: 20 February 2019

This article is part of the thematic issue "Multicomponent reactions III".

Guest Editor: T. J. J. Müller

© 2019 Neochoritis et al.; licensee Beilstein-Institut.

License and terms: see end of document.

### Abstract

Macrocycles were designed to antagonize the protein–protein interaction p53-MDM2 based on the three-finger pharmacophore F<sup>19</sup>W<sup>23</sup>L<sup>25</sup>. The synthesis was accomplished by a rapid, one-pot synthesis of indole-based macrocycles based on Ugi macrocyclization. The reaction of 12 different  $\alpha,\omega$ -amino acids and different indole-3-carboxaldehyde derivatives afforded a unique library of macrocycles otherwise difficult to access. Screening of the library for p53-MDM2 inhibition by fluorescence polarization and <sup>1</sup>H, <sup>15</sup>N HSQC NMR measurements confirm MDM2 binding.

### Introduction

Macrocycles are the chemical entities that are consisting of a 12-membered or even bigger ring. It is estimated that 3% of the known natural products consists of a macrocyclic ring [1-5]. Compared to macrocycles in synthetic molecules, the aforementioned occurrence is still over proportional; for that reason, these compounds have delighted scientists worldwide due to their special physicochemical properties, their roles in biological systems and the associated synthetic challenges [6,7]. However, only few synthetic methods allow for the convergent and fast access to a large macrocyclic chemical space [8-10]; most

of the times their synthesis is complex, multistep and sequential [11,12]. For this reason a great effort is ongoing to utilize multicomponent reactions for the synthesis of macrocycles [8,13-25].

The p53 protein is a well-studied protein which has a leading role in protecting our organism from cancer. It was found that most of the human cancers have either mutated the p53 itself or the p53 pathway is inhibited. The latter group of tumors retains the wild type p53 (wt-p53) but its pathway is inactivated by

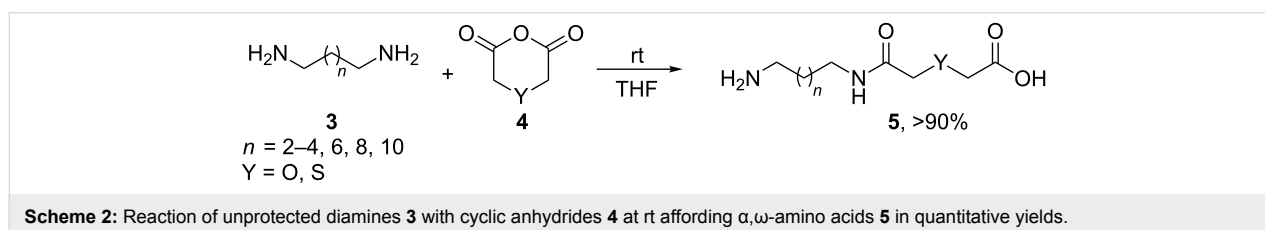
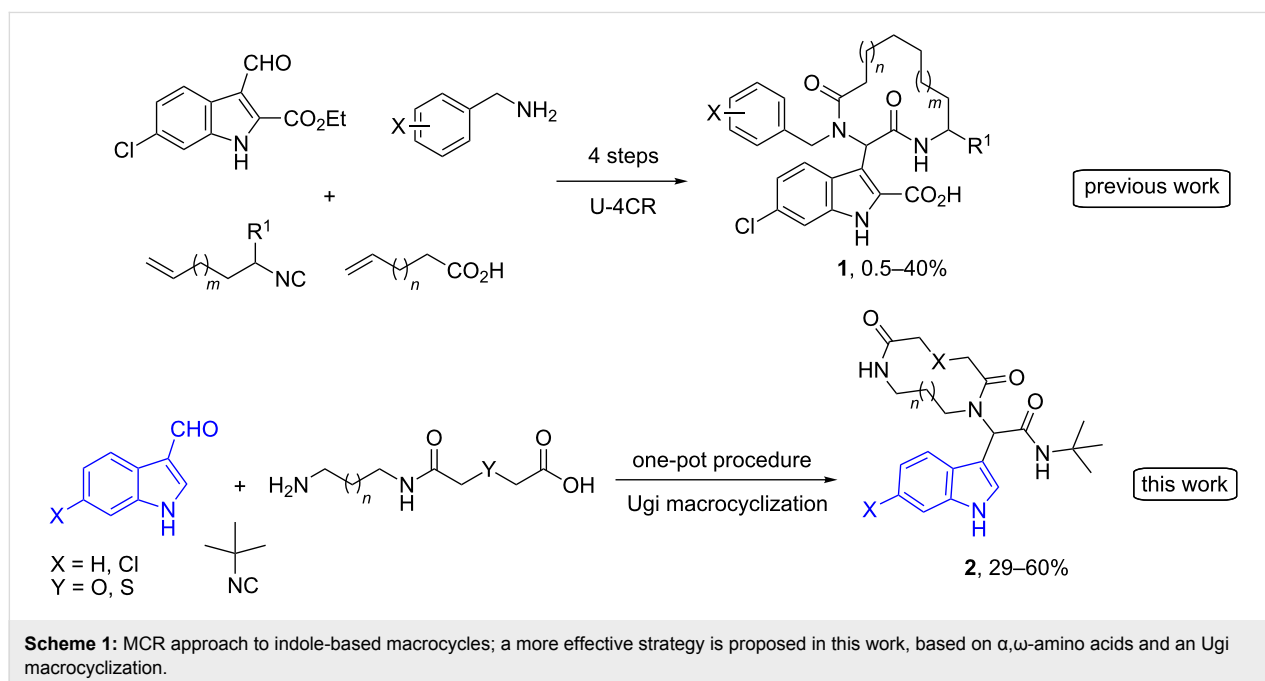
negative regulators, mainly the MDM2 and MDMX proteins. Thus, the design and synthesis of an inhibitor of the MDM2–p53 interaction could enable p53 and reverse tumor formation [26–28]. Based on our knowledge to antagonize the oncogenic protein–protein interaction p53–MDM2 [23,29–40] we designed macrocyclic inhibitors in continuation of our previous work [13,23]. Herein, an indole-based macrocycle synthesis is reported in a one-pot fashion based on Ugi macrocyclization with readily available  $\alpha,\omega$ -amino acids. Moreover, in continuation of our efforts in the design and synthesis of macrocycles targeting the p53–MDM2 interaction demonstrating the potential of these indole-based macrocycles, a subset of them was screened searching for MDM2 inhibitors. Compared to our previous indole-based macrocycles **1** following a different strategy (employing a classical Ugi-4C as the key reaction) [23], this one-pot Ugi macrocyclization leading to macrocycles **2** offers speed (one-pot procedure with one purification step), much better yields, no need of expensive catalysts as in ring-closing metathesis (RCM) reaction and higher complexity/diversity on the macrocyclic ring, e.g., insertion of heteroatoms that could improve the ADMET properties (Scheme 1) [4].

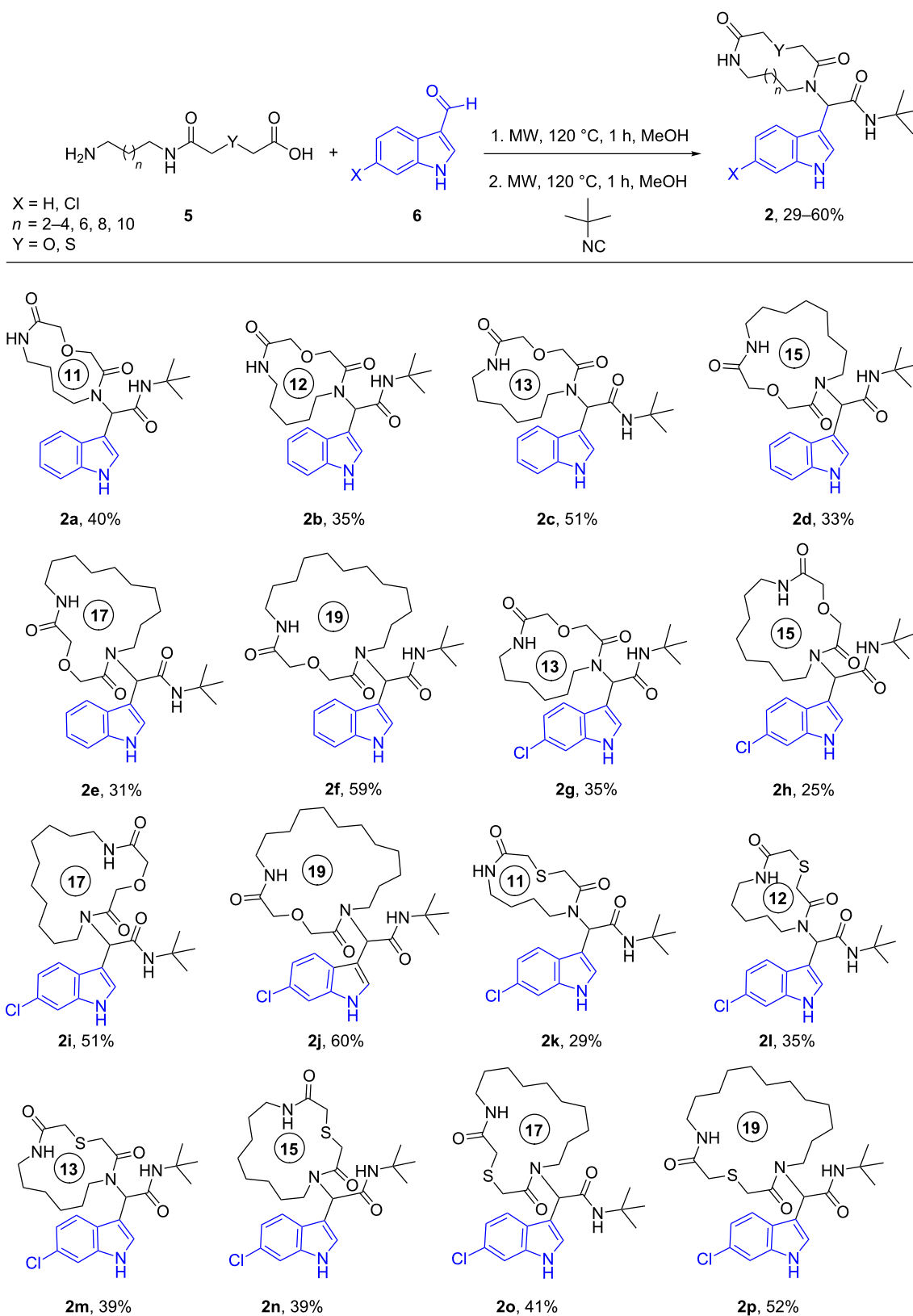
## Results and Discussion

### Synthesis

Based on our previous studies [13], unprotected diamines **3** were reacted in one-step with cyclic anhydrides **4** at rt affording the appropriate  $\alpha,\omega$ -amino acids **5** in excellent yields (see Supporting Information File 1). Elongated diamines ( $n = 2–4, 6, 8$  and 10) and cyclic anhydrides that bear a heteroatom in the 4-position as oxygen or sulfur ( $Y = O, S$ , Scheme 2) were employed in order to enhance the diversity of our macrocycles [4]. Thus, in a parallel way, we readily synthesized 12 different amino acids which were subsequently subjected to the Ugi macrocyclization.

After quite some optimization, we improved the Ugi-macrocyclization procedure compared to our previous findings utilizing microwave irradiation (see Supporting Information File 1); Firstly, the corresponding amino acid was irradiated with indole-3-carboxaldehyde derivatives **6** using MeOH as solvent (5 mL) at 120 °C for 1 h. Then, *tert*-butyl isocyanide was added, diluted with more MeOH and irradiated again the reaction mixture at 120 °C for an additional 1 h in a final concentration of 0.1 M (Scheme 3). By this way, a rapid, one-





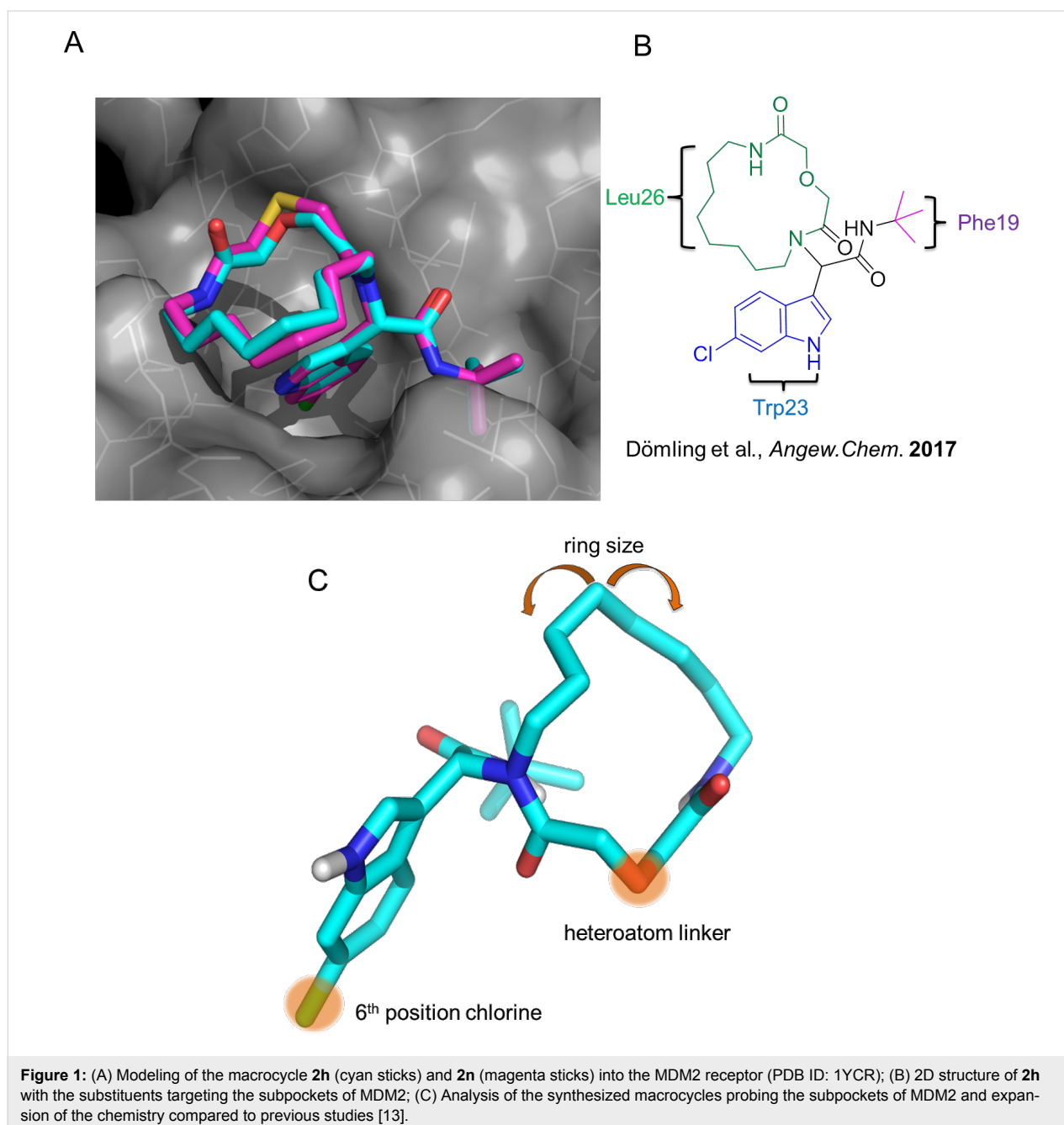
**Scheme 3:** Ugi macrocyclization in a one-pot fashion and synthesis of diverse indole-based macrocycles. The circle depicts the size number of the macrocycle.

pot access to macrocycles **2a–p** was achieved otherwise very difficult to synthesize in relatively good yields (29–60%). 16 different indole-based macrocycles were synthesized with their size varying from 11–13, 15, 17 and 19 atoms (Scheme 3).

### Biological evaluation

Our previously introduced three-point pharmacophore model on mimicking the hot triad (Phe19, Trp23 and Leu26, F<sup>19</sup>W<sup>23</sup>L<sup>26</sup>) was the basis of the evaluation of the current derivatives as potent inhibitors [33]. The indole moiety could be used not only to

constrain the two other substituents but also as an “anchor” mimicking the Trp23. The bulky *tert*-butyl group would mimic the Phe19 and the macrocyclic ring would fill the Leu26 sub-pocket as shown by our docking studies (Figure 1A,B, Figure S4 in Supporting Information File 1). Thus, extending our previous work [13], the Leu26 subpocket was probed by utilizing the different ring sizes and the different heteroatoms (oxygen or sulfur) of our macrocyclic library. In addition, the influence of the chlorine atom in the 6-position of the indole ring (Figure 1C) was examined. Macrocycles **2a–j** consist of an oxygen linker whereas **2g–j** bear also a chlorine atom in the

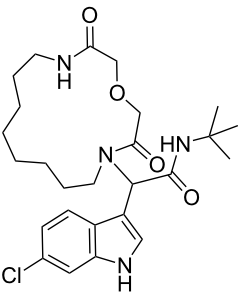
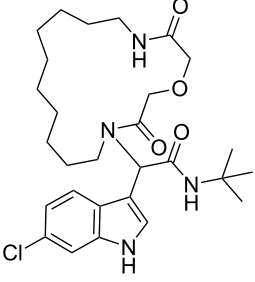
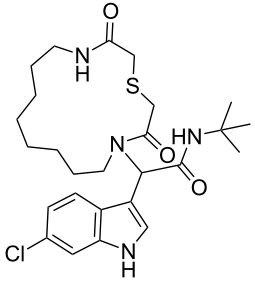
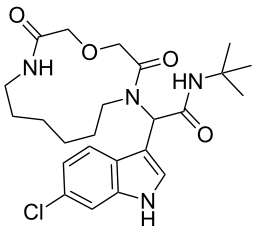


6-position in the indole ring. Macrocycles **2k–p** incorporate both a sulfur linker and the chlorine on the indole ring (Scheme 3).

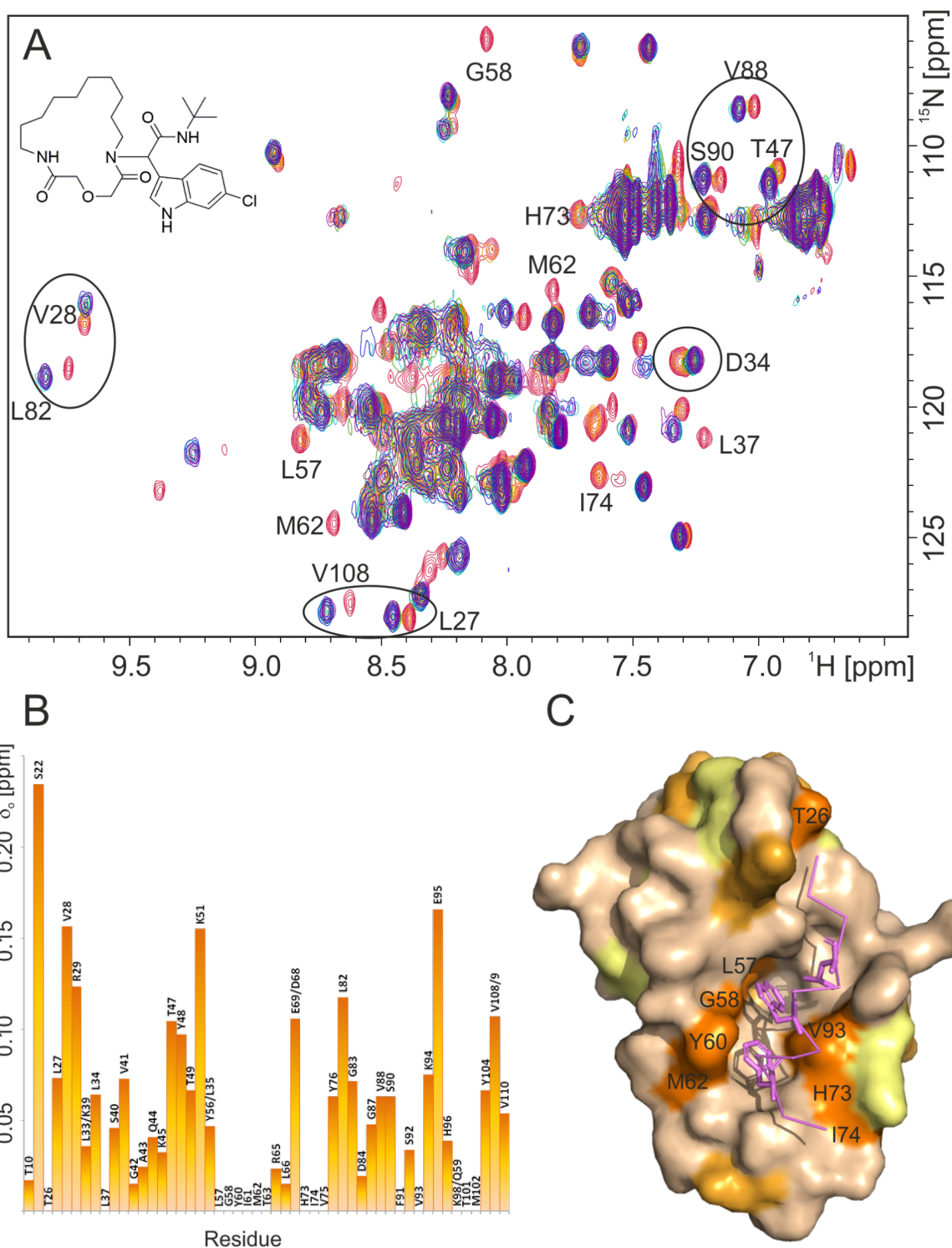
In order to exclude false positive hits, two biorthogonal assays were chosen;  $^1\text{H},^{15}\text{N}$  HSQC NMR and fluorescence polarization (FP, Table 1). FP assay was employed to determine the inhibitory affinities ( $K_i$ ) of the derivatives against MDM2 as previously described [36]. Besides **2h** ( $K_i = 2.3 \mu\text{M}$ ,  $K_d = 12.1 \mu\text{M}$ ), it was shown that **2i** demonstrated a promising activity with a  $K_i$  of  $5.5 \mu\text{M}$ . Furthermore,  $^1\text{H},^{15}\text{N}$  HSQC

showed a  $K_d$  of  $4.8 \mu\text{M}$  (Table 1, Figure 2). Moreover, macrocycles **2g** and **2n** demonstrated a  $K_d$  of  $9 \mu\text{M}$  and  $17 \mu\text{M}$ , respectively (Table 1). With this preliminary analysis, it was found that a ring size of 15–17 atoms and an oxygen as the heteroatom linker improves the binding affinity. All the active macrocycles have a 6-chloro-substituted indole core. It is well established that at the bottom of the Try23 pocket a hydrophobic small subpocket exists which is formed by Phe86, Ile103, Leu82 and Leu57. This pocket when filled with a smaller hydrophobic substituent such as -Cl boosts the inhibitor activity in accordance with literature [33].

**Table 1:** Measurement of  $K_i$  and  $K_d$  of the selected macrocycles based on FP and  $^1\text{H},^{15}\text{N}$  HSQC NMR assays, respectively.<sup>a</sup>

Entry	Name	Structure	$K_i$ MDM2 [ $\mu\text{M}$ ]	$K_d$ MDM2 [ $\mu\text{M}$ ]
1	<b>2h</b>		2.3	$12.1 \pm 8.5$
2	<b>2i</b>		5.5	$4.8 \pm 1.5$
3	<b>2n</b>		316	$17.2 \pm 3.8$
4	<b>2g</b>		n.a.	$8.9 \pm 1.2$

<sup>a</sup>n.a. no activity against MDM2 protein.  $K_i$  and  $K_d$  values were calculated based on fluorescence polarization binding and  $^1\text{H},^{15}\text{N}$  HSQC NMR assay, respectively.



**Figure 2:** (A) Overlay of  $^1\text{H}$ ,  $^{15}\text{N}$ -HSQC spectra of the reference MDM2 (red) and the titration steps with the **2i** inhibitor. MDM2/**2i** ratios 4:1 (orange), 4:2 (yellow), 4:3 (green), 1:1 (light blue), 1:2 (blue), 1:5 (purple). Examples of most perturbed residues are labeled on the spectrum. (B) Normalized chemical shift perturbations ( $\delta_0$ ) of MDM2 residue (calculated according to Stoll et al. [41]). Residue with  $\delta_0$  equal 0 are either disappearing from MDM2 spectrum upon titration or cannot be identified. (C) Chemical shift perturbations plotted onto the structure of MDM2 (wheat); orange (despairing – indicating stronger binding), light orange ( $>0.1$  ppm), yellow (0.05–0.1 ppm). Residues which disappear upon titration experiment are labeled on the Mdm2 surface.

## Conclusion

We effectively synthesized p53-MDM2 antagonists based on an artificial macrocyclic scaffold. 16 different derivatives were obtained and screened. The aforementioned artificial macrocycles combine the indole ring, a motif found in many bioactive molecules with the drug-like properties of a non-peptide macrocycle. We hypothesize that these chimeric derivatives of an indole and a macrocycle will offer new potential on specific PPIs and other postgenomic targets as it was demonstrated with the p53-MDM2 interaction.

## Supporting Information

### Supporting Information File 1

Experimental procedures, analytical data, NMR spectra, fluorescence polarization binding assays, <sup>1</sup>H, <sup>15</sup>N HSQC NMR spectra of <sup>15</sup>N-labeled MDM2 and computational modeling studies.

[<https://www.beilstein-journals.org/bjoc/content/supplementary/1860-5397-15-45-S1.pdf>]

## Acknowledgements

This research has been supported to (AD) by the National Institute of Health (NIH) (2R01GM097082-05), the European Lead Factory (IMI) under grant agreement number 115489, the Qatar National Research Foundation (NPRP6-065-3-012) and to (TAH) by Grant UMO-2014/12/W/NZ1/00457 from the National Science Centre, Poland. Moreover funding was received through ITN “Accelerated Early stage drug dIScovery” (AEGIS, grant agreement No 675555) and COFUND ALERT (grant agreement No 665250), Hartstichting (ESCAPE-HF, 2018B012) and KWF Kankerbestrijding grant (grant agreement No 10504).

## ORCID® iDs

Constantinos G. Neochoritis - <https://orcid.org/0000-0001-5098-5504>

Maryam Kazemi Miraki - <https://orcid.org/0000-0003-4834-1990>

Eman M. M. Abdelraheem - <https://orcid.org/0000-0002-9008-2729>

Ewa Surmiak - <https://orcid.org/0000-0002-4103-4675>

Tad A. Holak - <https://orcid.org/0000-0001-9369-6024>

## References

- Giordanetto, F.; Kihlberg, J. *J. Med. Chem.* **2014**, *57*, 278–295. doi:10.1021/jm400887j
- Davis, A. M.; Plowright, A. T.; Valeur, E. *Nat. Rev. Drug Discovery* **2017**, *16*, 681–698. doi:10.1038/nrd.2017.146
- Scott, D. E.; Bayly, A. R.; Abell, C.; Skidmore, J. *Nat. Rev. Drug Discovery* **2016**, *15*, 533–550. doi:10.1038/nrd.2016.29
- Villar, E. A.; Beglov, D.; Chennamadhavuni, S.; Porco, J. A.; Kozakov, D.; Vajda, S.; Whitty, A. *Nat. Chem. Biol.* **2014**, *10*, 723–731. doi:10.1038/nchembio.1584
- Doak, B. C.; Zheng, J.; Dobritsch, D.; Kihlberg, J. *J. Med. Chem.* **2016**, *59*, 2312–2327. doi:10.1021/acs.jmedchem.5b01286
- Yu, X.; Sun, D. *Molecules* **2013**, *18*, 6230–6268. doi:10.3390/molecules18066230
- White, C. J.; Yudin, A. K. *Nat. Chem.* **2011**, *3*, 509–524. doi:10.1038/nchem.1062
- Failli, A.; Immer, H.; Götz, M. *Can. J. Chem.* **1979**, *57*, 3257–3261. doi:10.1139/v79-533
- Gartner, Z. J. *Science* **2004**, *305*, 1601–1605. doi:10.1126/science.1102629
- Jebraill, M. J.; Ng, A. H. C.; Rai, V.; Hili, R.; Yudin, A. K.; Wheeler, A. R. *Angew. Chem., Int. Ed.* **2010**, *49*, 8625–8629. doi:10.1002/anie.201001604
- Koopmanschap, G.; Ruijter, E.; Orru, R. V. A. *Beilstein J. Org. Chem.* **2014**, *10*, 544–598. doi:10.3762/bjoc.10.50
- Iyoda, M.; Yamakawa, J.; Rahman, M. J. *Angew. Chem., Int. Ed.* **2011**, *50*, 10522–10553. doi:10.1002/anie.201006198
- Madhavachary, R.; Abdelraheem, E. M. M.; Rossetti, A.; Twarda-Clapa, A.; Musielak, B.; Kurpiewska, K.; Kalinowska-Tłuścik, J.; Holak, T. A.; Dömling, A. *Angew. Chem., Int. Ed.* **2017**, *56*, 10725–10729. doi:10.1002/anie.201704426
- Abdelraheem, E.; Khaksar, S.; Dömling, A. *Synthesis* **2018**, *50*, 1027–1038. doi:10.1055/s-0036-1590946
- Janvier, P.; Bois-Choussy, M.; Bienaymé, H.; Zhu, J. *Angew. Chem., Int. Ed.* **2003**, *42*, 811–814. doi:10.1002/anie.200390216
- Wessjohann, L. A.; Voigt, B.; Rivera, D. G. *Angew. Chem., Int. Ed.* **2005**, *44*, 4785–4790. doi:10.1002/anie.200500019
- Wessjohann, L. A.; Rivera, D. G.; Vercillo, O. E. *Chem. Rev.* **2009**, *109*, 796–814. doi:10.1021/cr8003407
- Abdelraheem, E. M. M.; Kurpiewska, K.; Kalinowska-Tłuścik, J.; Dömling, A. *J. Org. Chem.* **2016**, *81*, 8789–8795. doi:10.1021/acs.joc.6b01430
- Beck, B.; Larbig, G.; Mejat, B.; Magnin-Lachaux, M.; Picard, A.; Herdtweck, E.; Dömling, A. *Org. Lett.* **2003**, *5*, 1047–1050. doi:10.1021/ol034077e
- Liao, G. P.; Abdelraheem, E. M. M.; Neochoritis, C. G.; Kurpiewska, K.; Kalinowska-Tłuścik, J.; McGowan, D. C.; Dömling, A. *Org. Lett.* **2015**, *17*, 4980–4983. doi:10.1021/acs.orglett.5b02419
- Abdelraheem, E. M. M.; Khaksar, S.; Kurpiewska, K.; Kalinowska-Tłuścik, J.; Shaabani, S.; Dömling, A. *J. Org. Chem.* **2018**, *83*, 1441–1447. doi:10.1021/acs.joc.7b02984
- Abdelraheem, E.; Shaabani, S.; Dömling, A. *Synlett* **2018**, *29*, 1136–1151. doi:10.1055/s-0036-1591975
- Estrada-Ortiz, N.; Neochoritis, C. G.; Twarda-Clapa, A.; Musielak, B.; Holak, T. A.; Dömling, A. *ACS Med. Chem. Lett.* **2017**, *8*, 1025–1030. doi:10.1021/acsmedchemlett.7b00219
- Abdelraheem, E. M. M.; de Haan, M. P.; Patil, P.; Kurpiewska, K.; Kalinowska-Tłuścik, J.; Shaabani, S.; Dömling, A. *Org. Lett.* **2017**, *19*, 5078–5081. doi:10.1021/acs.orglett.7b02319
- Abdelraheem, E. M. M.; Madhavachary, R.; Rossetti, A.; Kurpiewska, K.; Kalinowska-Tłuścik, J.; Shaabani, S.; Dömling, A. *Org. Lett.* **2017**, *19*, 6176–6179. doi:10.1021/acs.orglett.7b03094
- Gu, J.; Wang, B.; Liu, Y.; Zhong, L.; Tang, Y.; Guo, H.; Jiang, T.; Wang, L.; Li, Y.; Cai, L. *Eur. J. Cancer* **2014**, *50*, 1184–1194. doi:10.1016/j.ejca.2013.12.027
- Brown, C. J.; Lain, S.; Verma, C. S.; Fersht, A. R.; Lane, D. P. *Nat. Rev. Cancer* **2009**, *9*, 862–873. doi:10.1038/nrc2763

28. Cheok, C. F.; Verma, C. S.; Baselga, J.; Lane, D. P. *Nat. Rev. Clin. Oncol.* **2011**, *8*, 25–37. doi:10.1038/nrclinonc.2010.174
29. Huang, Y.; Wolf, S.; Beck, B.; Köhler, L.-M.; Khoury, K.; Popowicz, G. M.; Goda, S. K.; Subklewe, M.; Twarda, A.; Holak, T. A.; Dömling, A. *ACS Chem. Biol.* **2014**, *9*, 802–811. doi:10.1021/cb400728e
30. Bista, M.; Wolf, S.; Khoury, K.; Kowalska, K.; Huang, Y.; Wrona, E.; Arciniega, M.; Popowicz, G. M.; Holak, T. A.; Dömling, A. *Structure* **2013**, *21*, 2143–2151. doi:10.1016/j.str.2013.09.006
31. Estrada-Ortiz, N.; Neochoritis, C. G.; Dömling, A. *ChemMedChem* **2016**, *11*, 757–772. doi:10.1002/cmdc.201500487
32. Neochoritis, C. G.; Wang, K.; Estrada-Ortiz, N.; Herdtweck, E.; Kubica, K.; Twarda, A.; Zak, K. M.; Holak, T. A.; Dömling, A. *Bioorg. Med. Chem. Lett.* **2015**, *25*, 5661–5666. doi:10.1016/j.bmcl.2015.11.019
33. Czarna, A.; Beck, B.; Srivastava, S.; Popowicz, G. M.; Wolf, S.; Huang, Y.; Bista, M.; Holak, T. A.; Dömling, A. *Angew. Chem., Int. Ed.* **2010**, *49*, 5352–5356. doi:10.1002/anie.201001343
34. Neochoritis, C.; Estrada-Ortiz, N.; Khoury, K.; Dömling, A. *Annu. Rep. Med. Chem.* **2014**, *49*, 167–187. doi:10.1016/b978-0-12-800167-7.00012-2
35. Popowicz, G. M.; Czarna, A.; Wolf, S.; Wang, K.; Wang, W.; Dömling, A.; Holak, T. A. *Cell Cycle* **2010**, *9*, 1104–1111. doi:10.4161/cc.9.6.10956
36. Czarna, A.; Popowicz, G. M.; Pecak, A.; Wolf, S.; Dubin, G.; Holak, T. A. *Cell Cycle* **2009**, *8*, 1176–1184. doi:10.4161/cc.8.8.8185
37. Huang, Y.; Wolf, S.; Koes, D.; Popowicz, G. M.; Camacho, C. J.; Holak, T. A.; Dömling, A. *ChemMedChem* **2012**, *7*, 49–52. doi:10.1002/cmdc.201100428
38. Surmiak, E.; Neochoritis, C. G.; Musielak, B.; Twarda-Clapa, A.; Kurpiewska, K.; Dubin, G.; Camacho, C.; Holak, T. A.; Dömling, A. *Eur. J. Med. Chem.* **2017**, *126*, 384–407. doi:10.1016/j.ejmech.2016.11.029
39. Shaabani, S.; Neochoritis, C. G.; Twarda-Clapa, A.; Musielak, B.; Holak, T. A.; Dömling, A. *Med. Chem. Commun.* **2017**, *8*, 1046–1052. doi:10.1039/c7md00058h
40. Koes, D. R.; Dömling, A.; Camacho, C. J. *Protein Sci.* **2018**, *27*, 229–232. doi:10.1002/pro.3303
41. Stoll, R.; Renner, C.; Hansen, S.; Palme, S.; Klein, C.; Belling, A.; Zeslawski, W.; Kamionka, M.; Rehm, T.; Mühlhahn, P.; Schumacher, R.; Hesse, F.; Kaluza, B.; Voelter, W.; Engh, R. A.; Holak, T. A. *Biochemistry* **2001**, *40*, 336–344. doi:10.1021/bi000930v

## License and Terms

This is an Open Access article under the terms of the Creative Commons Attribution License (<http://creativecommons.org/licenses/by/4.0>). Please note that the reuse, redistribution and reproduction in particular requires that the authors and source are credited.

The license is subject to the *Beilstein Journal of Organic Chemistry* terms and conditions:

(<https://www.beilstein-journals.org/bjoc>)

The definitive version of this article is the electronic one which can be found at:

doi:10.3762/bjoc.15.45



# Selectivity in multiple multicomponent reactions: types and synthetic applications

Ouldouz Ghashghaei<sup>1</sup>, Francesca Seghetti<sup>2</sup> and Rodolfo Lavilla<sup>\*1</sup>

## Review

Open Access

### Address:

<sup>1</sup>Laboratory of Medicinal Chemistry, Faculty of Pharmacy and Food Sciences and Institute of Biomedicine (IBUB), University of Barcelona, Av. de Joan XXIII, 27-31, 08028 Barcelona, Spain and <sup>2</sup>Department of Pharmacy and Biotechnology (FaBiT), University of Bologna, Via Belmeloro, 6, 40126, Bologna, Italy

### Email:

Rodolfo Lavilla\* - rlavilla@ub.edu

\* Corresponding author

### Keywords:

isocyanides; multicomponent reactions; reaction discovery; selectivity

*Beilstein J. Org. Chem.* **2019**, *15*, 521–534.

doi:10.3762/bjoc.15.46

Received: 13 December 2018

Accepted: 07 February 2019

Published: 21 February 2019

This article is part of the thematic issue "Multicomponent reactions III".

Guest Editor: T. J. J. Müller

© 2019 Ghashghaei et al.; licensee Beilstein-Institut.

License and terms: see end of document.

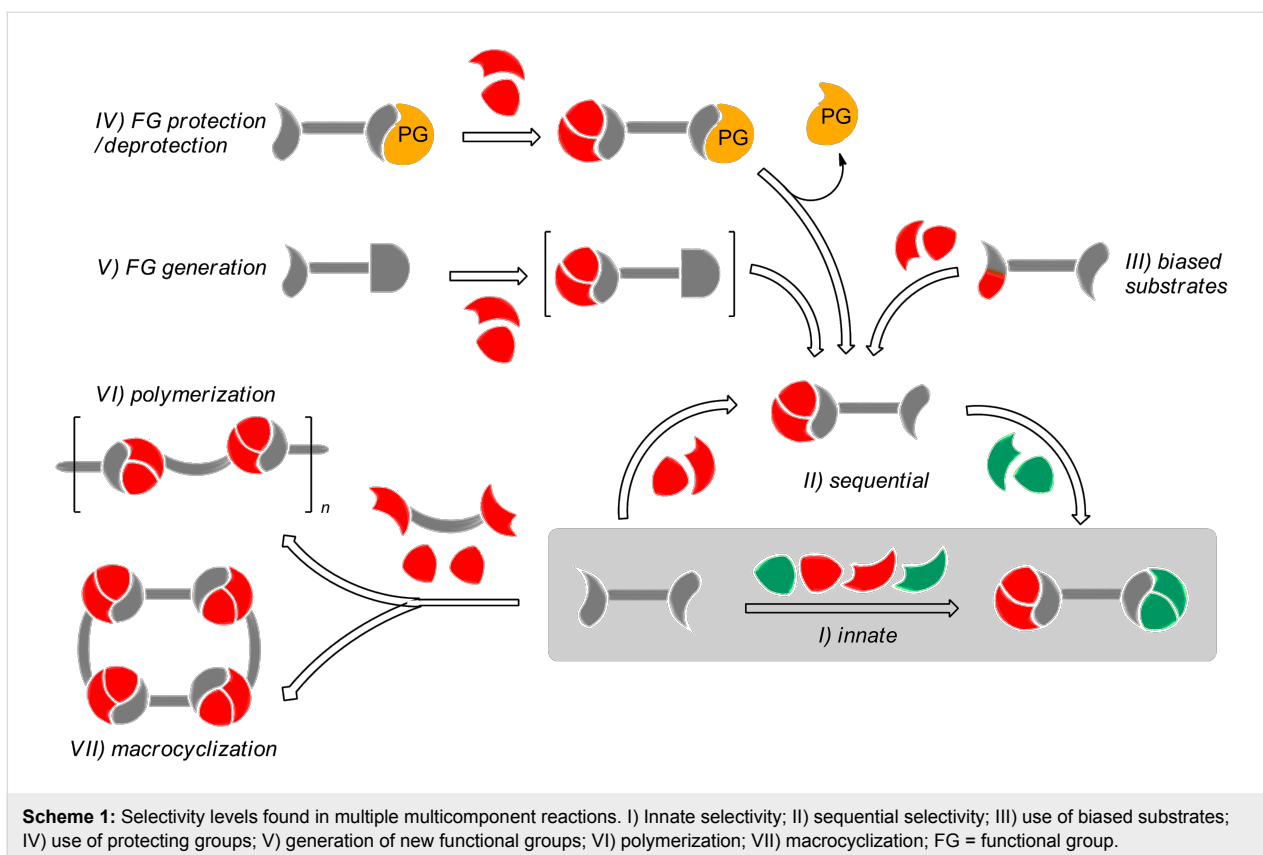
## Abstract

Multiple multicomponent reactions reach an unparalleled level of connectivity, leading to highly complex adducts. Usually, only one type of transformation involving the same set of reactants takes place. However, in some occasions this is not the case. Selectivity issues then arise, and different scenarios are analyzed. The structural pattern of the reactants, the reaction design and the experimental conditions are the critical factors dictating selectivity in these processes.

## Introduction

Organic synthesis has become fundamental in science and technology, affecting many aspects of our lives. Therefore, there is a big need for the optimized preparation of a variety of compounds [1-3]. In this context, multicomponent reactions (MCRs) hold a privileged position, allowing the formation of many bonds and connecting three or more reactants in one step [4]. A particularly attractive and synthetically productive set of MCRs involve di/polyfunctionalized substrates that can, consequently, lead to repeated processes. The so-called multiple multicomponent reactions (MMCRs) display impressive power regarding connectivity and bond-forming efficiency and can be considered as ideal synthetic processes in many aspects [5].

These features may be maximized if the controlled incorporation of distinct reactant units, belonging to the same class, along the transformation would be feasible (Scheme 1). This review, which does not intend to be exhaustive, deals with the selectivity levels found in the literature and their impact on the synthetic outcome. In this way we may find different scenarios: i) completely unselective combinations leading to mixtures, symmetrical adducts or polymers; ii) structurally preorganized systems allowing the generation of macrocycles and iii) selective processes in which a determined combination arises in a sequential manner, either directly or indirectly, through functional group deprotection/generation. Stereoselectivity (where



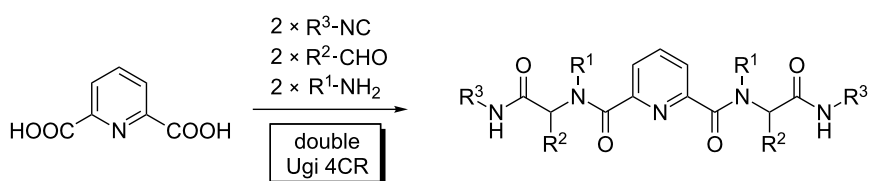
applicable) arising out of the individual MCRs or in the final adduct, is not contemplated. Only the connectivity issues related with the identity of the reactants are taken into account.

## Review

Substrates displaying two (or more) identical functional groups (FGs) have been reacted in a variety of MCRs. An early example involves the synthesis of protease inhibitors by double Ugi 4CR using pyridine-2,6-dicarboxylic acid, isocyanides, amines and aldehydes (Scheme 2), and the combinatorial implications of this protocol were analyzed [6]. Ugi and Dömling soon realized the potential of such experiments, which helped to pave the way of combinatorial chemistry and its applications for the fast generation of pharmacological hits through library deconvolution. The reactivity of the system led to complex product mixtures, with no practical substrate selectivity.

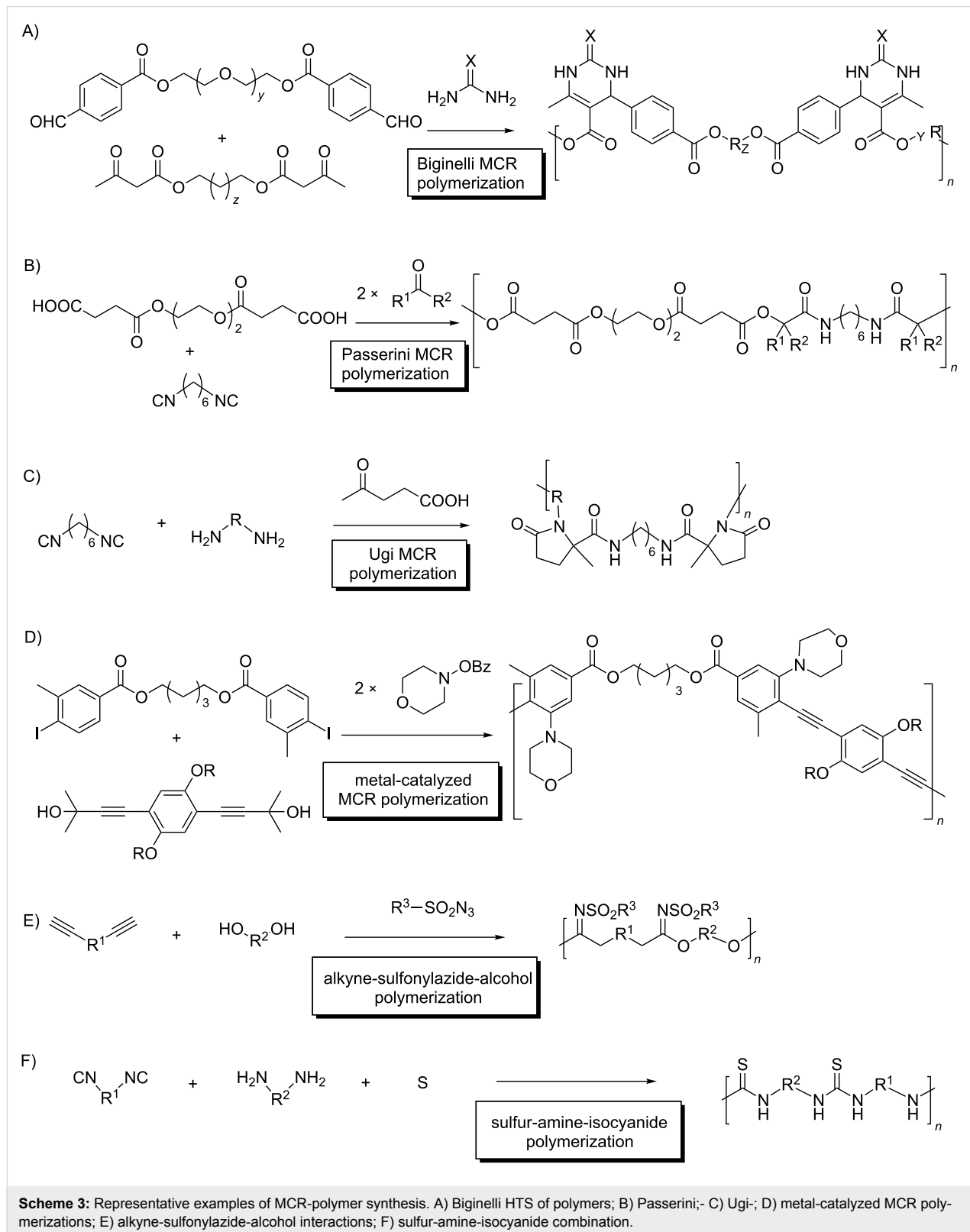
However, if in analogous experiments several reactants of a kind, displaying different reactivities, are used, their relative nucleophilicities/electrophilicities [7] may lead, in principle, to biased mixtures. At the same time, this innate selectivity is not straightforward, as the most reactive combination would promote a fast first MCR, and likely the following MCR processes may also involve this same set [8]. Experimental findings showing complex mixtures, although far from statistical product ratios, are the usual outcome of MMCRs involving several reactants of one kind.

There are, however, cases where this indiscriminate reactivity is synthetically useful: MCR polymerizations, typically involving two doubly functionalized reactants, which yield macromolecular adducts [9-11]. In these processes, the reactivity of the equivalent FGs is nearly identical in the reactants and in the



oligo/polymeric intermediates, as they are usually connected through long linear alkyl chains. Representative examples include polymerizations using Biginelli [12], Passerini [13], Ugi

[14], metal-catalyzed MCRs [15], and reactive combinations involving an alkyne-sulfonyl azide nucleophile [16] and sulfur, amines and isocyanides [17] (Scheme 3).



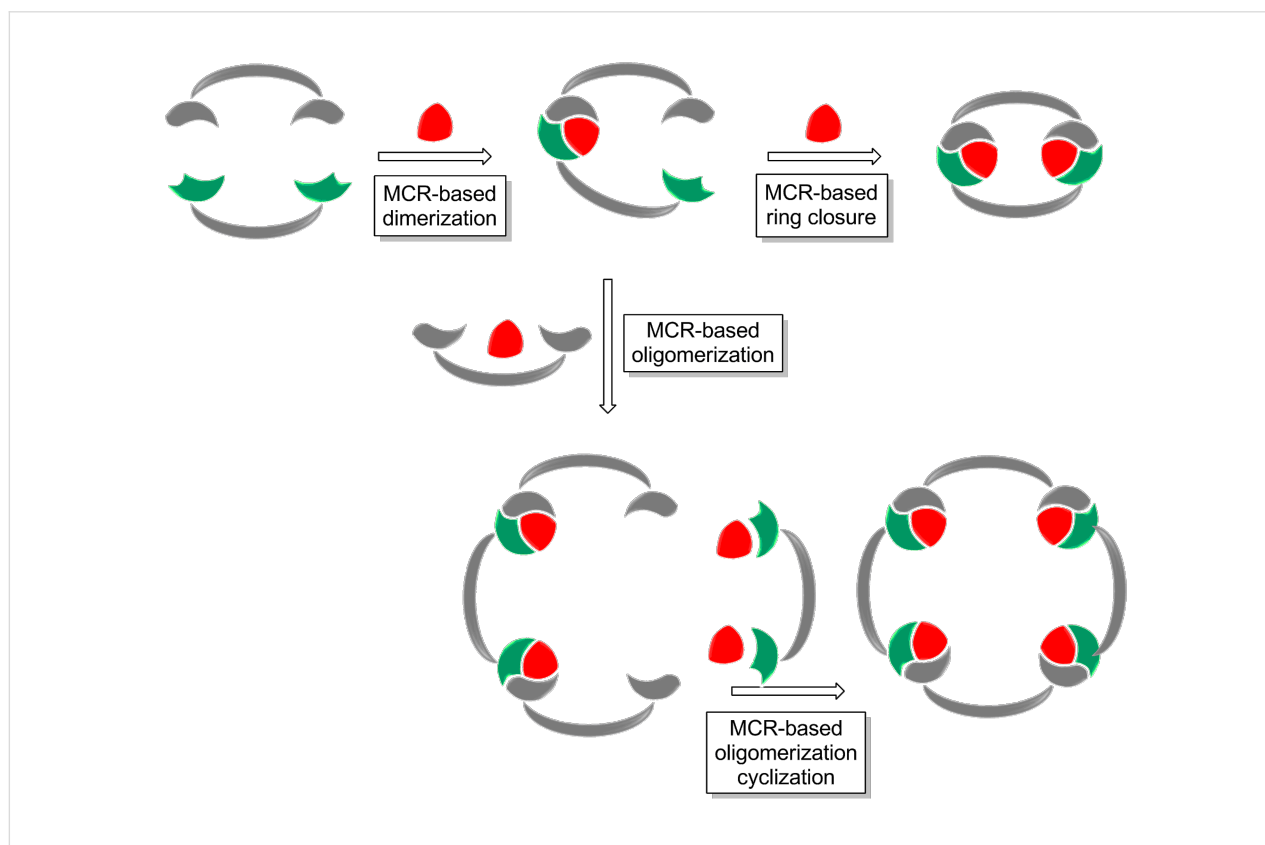
An interesting case, where this principle does not apply, is introduced by Wessjohann [5,18], who introduced a family of MMCRs leading to complex macrocyclic structures instead of linear polymer chains. In these examples, a low concentration together with the use of specific substrates tune the reactivity pattern, promoting intramolecular interactions over intermolecular polymerizations. Thus, the use of the right conditions and the intelligent choice of the polyfunctionalized building blocks, enable an “architectural approach” towards the MMCR synthesis of macrocyclic adducts [19].

This multiple multicomponent macrocyclization strategy [18,20] (Scheme 4) constitutes a breakthrough in the field, providing a powerful synthetic tool to systematically design and prepare a variety of structures. The implementation of this approach goes beyond simple macrocycles, and was exploited to deliver macromulticycles [21], supramolecular structures (cryptands, cages, cryptophanes, podands, etc.) [22–24], cyclic/macrocylic peptides [25] and other complex structures in a straightforward manner (Scheme 5). The diversity in these systems arises not only from combining a variety of building blocks (from simple aromatic and aliphatic substrates to peptides, steroids, sugars, etc.) [26], but also from the different MCRs used. Although the Ugi 4CR is the most commonly used

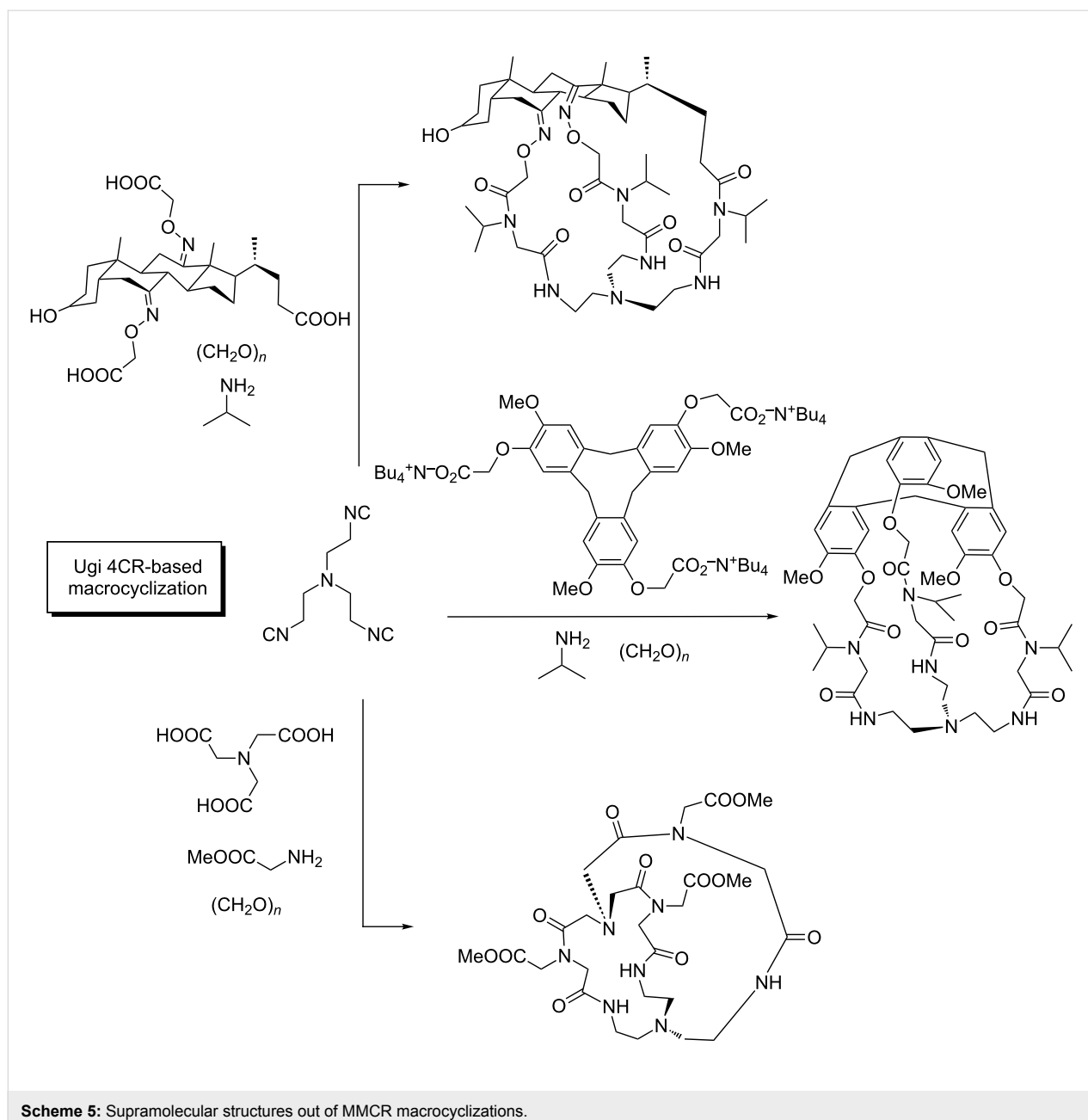
transformation in this context, interesting examples exploiting other MCRs have been reported (Scheme 6) [27,28].

However, when the first MCR step in the process leads to a less reactive intermediate, the system may stop temporarily at this level, and once completed, a second MCR with a distinct set of reagents may take place under more vigorous activation. This allows for selective sequential MMCRs, although there is a clear dependency on the structural features of a given substrate. For instance, all known examples deal with ditopic compounds, where the two reactive FGs are conjugated. In this way, after the initial MCR, the intermediate adduct is somewhat deactivated with respect to the initial substrate, and the remaining FG is less prone to suffer the same transformation. Relevant examples are shown in Scheme 7.

Terephthalaldehyde is capable of undergoing sequential MCRs in a selective manner with two different sets of reactants. In this way, a variety of transformations involving Groebke–Blackburn–Bienaymé (GBB)/Hantzsch, and Biginelli/Ugi-azide sequential reactions were reported by Shahrissa [29]. Similarly, Sharma and co-workers disclosed a related approach [30]. Moreover, 2,4-diaminopyrimidine underwent selective GBB processes leading to a single monoadduct, which reacted again



**Scheme 4:** Concept of multicomponent macrocyclization.

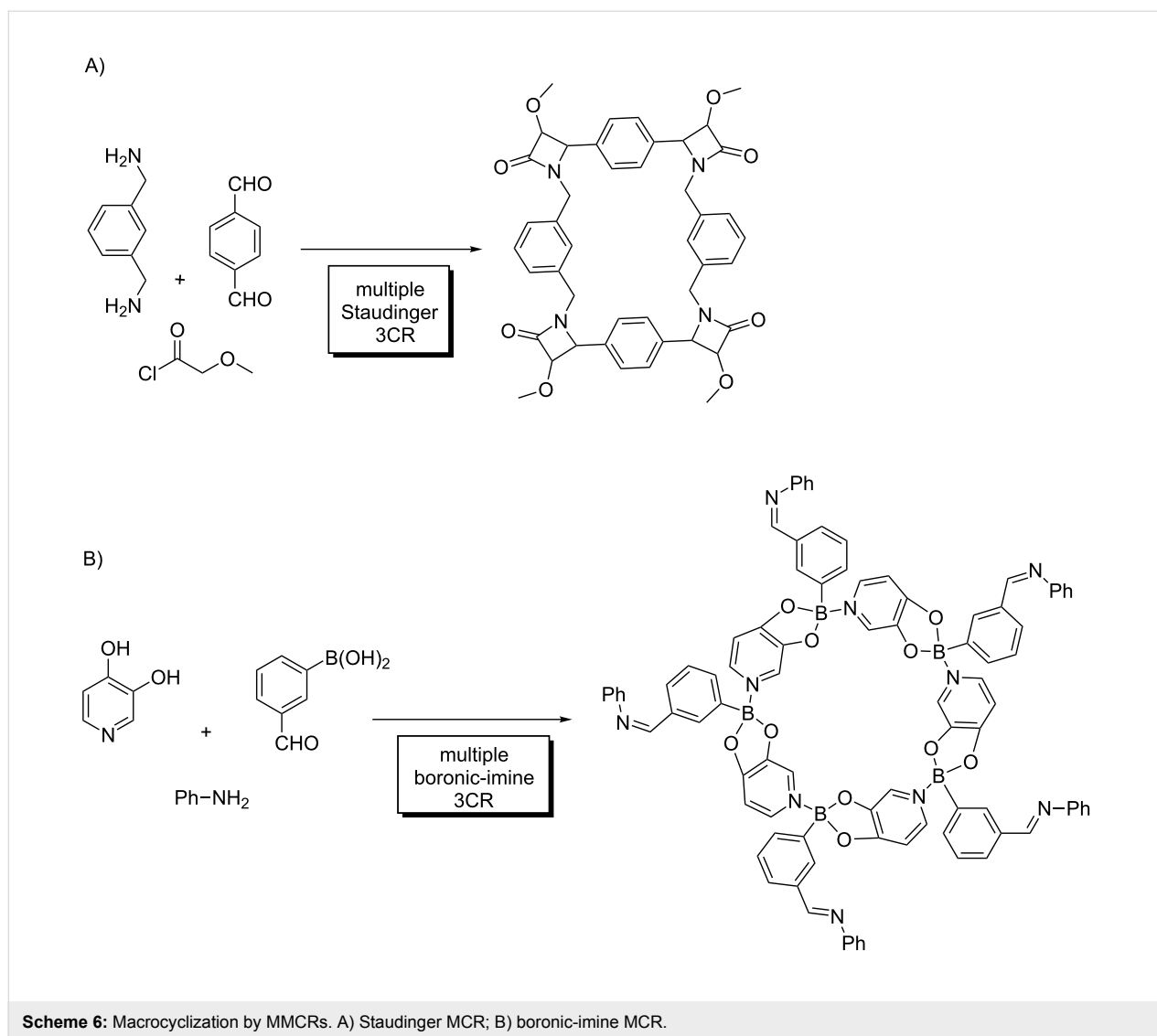


with another isocyanide/aldehyde pair to yield a 5-component adduct in a selective manner. Interestingly, the protocol allows control of the respective localization of all reactant inputs. Thus, inverting the order of the MCRs leads to the complementary disposition of the residues in the final MCR adduct [31].

Non-symmetrically polyfunctionalized components can significantly diversify the synthetic output of MMCRs. However, a limiting factor in the design of MMCRs with such components is the risk of generating undesired cross-adducts. This problem can be avoided by introduction of protecting groups or through the sequential generation of repeating FGs (see below). An al-

ternative strategy is to include those duplicated FGs displaying distinct reactivity. In this way, one FG selectively reacts through the first MCR, while its counterpart remains intact to be exploited in a subsequent transformation.

This elegant concept has been reported by Orru [32], exploiting a non-symmetrical diisocyanide **A** (Scheme 8). The designed sequence requires the  $\alpha$ -acidic isocyanide to undergo the 3CR leading to a 2-imidazoline in the first step, the aliphatic isocyanide remaining intact (without protection) and being later incorporated in a variety of isocyanide-based MCRs. In this way, the selective formation of intermediate **B**, leads to the

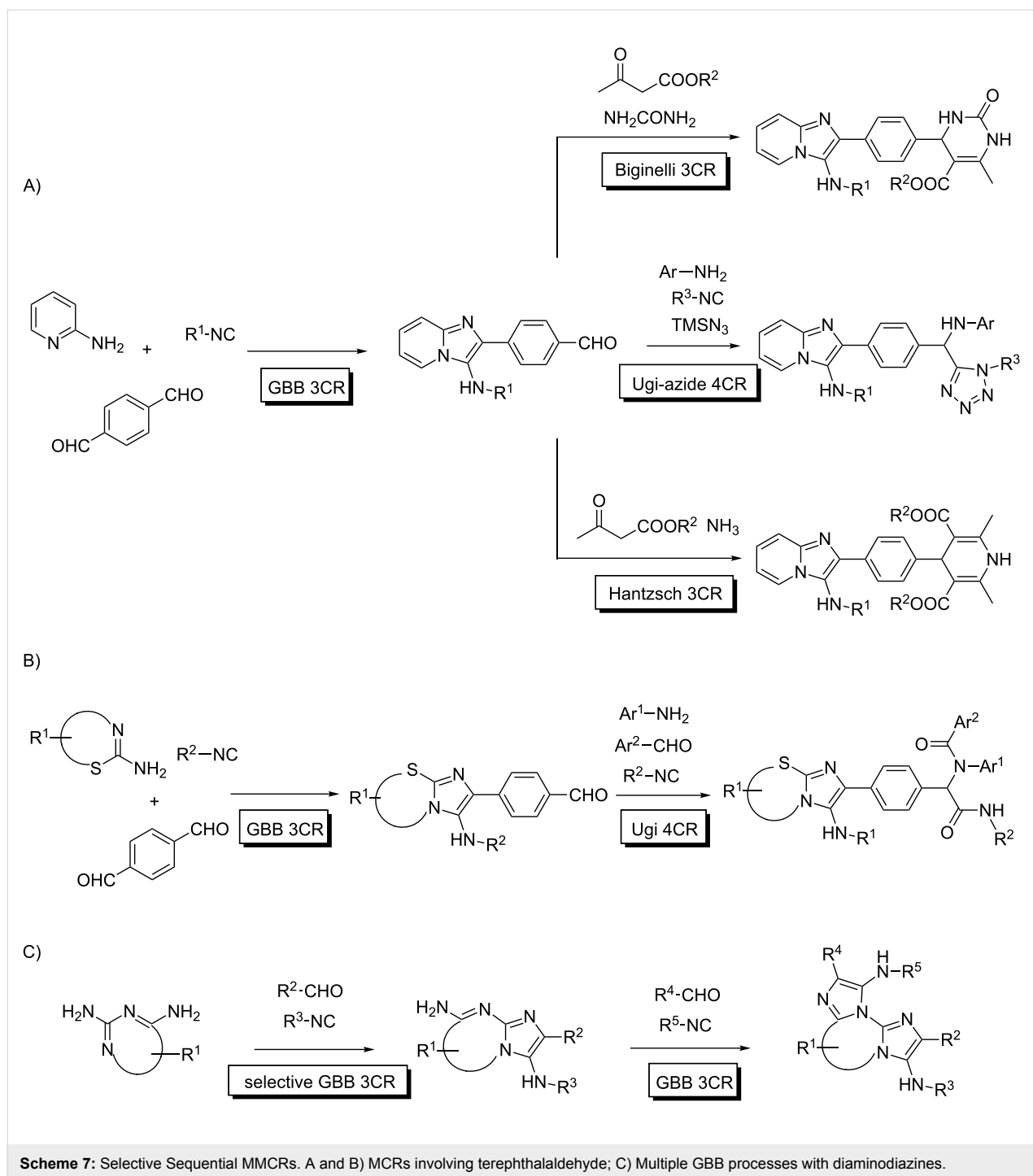


following MCR processes based in different isocyanide MCRs. This approach made possible a remarkable 8-CR process for the one-pot synthesis of compounds with up to 11 diversity points.

A conceptually distinct approach for selective MMCRs is based in reactivity features. The Union concept (the combination of MCRs) [33,34] is extremely fruitful and was developed by Ugi and Dömling to perform a 7CR out of the combination of Asinger and Ugi transformations (Scheme 9A) [35]. In this context, chemoselectivity can be achieved when the key polyfunctionalized reactants bear the adequate FGs and the combination of MCRs becomes feasible. This can happen either by the orthogonal reactivity of the participating FGs or because the sequential character of the process implies the participation of the first MCR adduct as a reactant in the following transformation. Several examples use this approach with the same set of reagents leading to MMCRs, with limited structural variability

(Scheme 9B and C) [36,37]. However, in some occasions the two processes are split up and higher levels of diversity can be achieved.

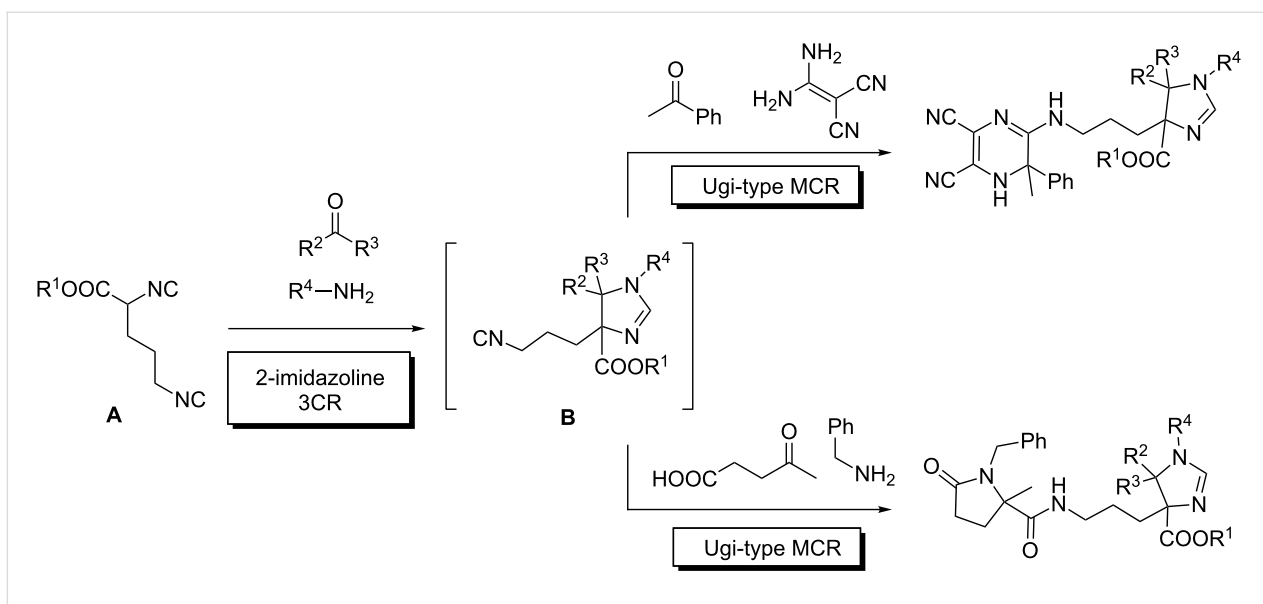
In these cases, the consecutive reactions lead to adducts displaying a diversity of substituents at several positions, which, in principle, can be located at will, in a controlled manner. For instance, the combination of a Petasis 3CR with an Ugi 4CR led to a peptide structure with six diversity points arising directly from the reactants (Scheme 10A) [38]. Similarly, a suitably substituted aldehyde participates in a GBB MCR to yield an adduct which participated in standard Ugi–Passerini processes through the carboxylic acid functional group, untouched in the first MCR (Scheme 10B) [39]. Furthermore, Reissert or Reissert/Ugi reactions can be linked with Povarov MCRs through the intermediacy of the enamine-containing adducts from the former processes (Scheme 10C) [40].



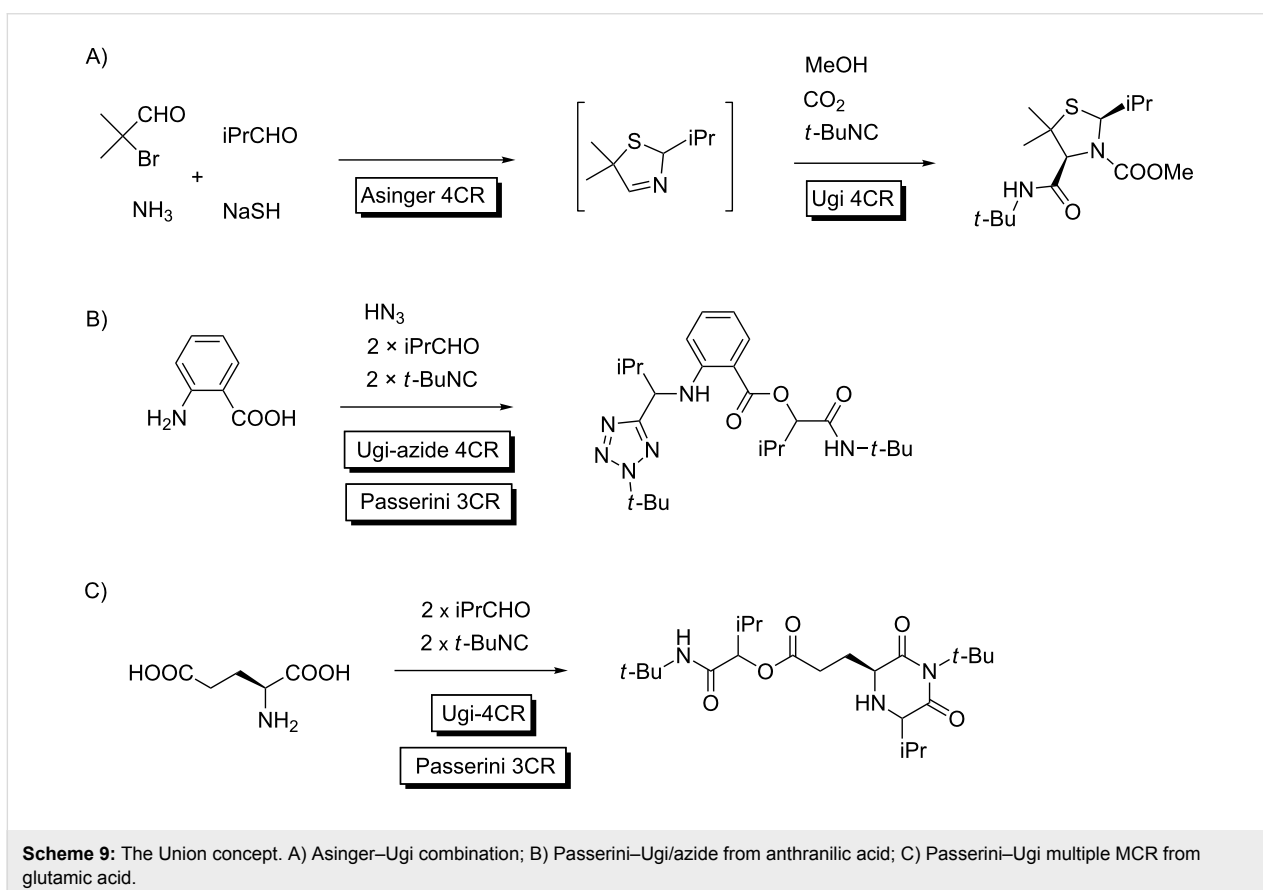
Many additional combinations arise from the Union concept, such as Bredereck–Passerini [41], pyridone-cyclocondensation/Passerini–Ugi [42], azadiene-keteneimine Diels–Alder [43], Asinger–Ugi [44], etc.

Another class of reactions highlight the importance of the distinct kinetic reactivity of similar FGs present in the reactants and in the initial adducts of the first transformation, then

enabling productive and selective combinations of the MCRs. The synthesis of aminomethyltetrazoles arising from two consecutive isocyanide-MCRs shows excellent selectivity and broad scope, and although it combines two different transformations, the amine component (ammonia in the starting mixture and a primary amino group in the first adduct) reacts at different rates in each substrate, allowing the controlled performance of both processes, leading to a formal two-step 6CR [45]



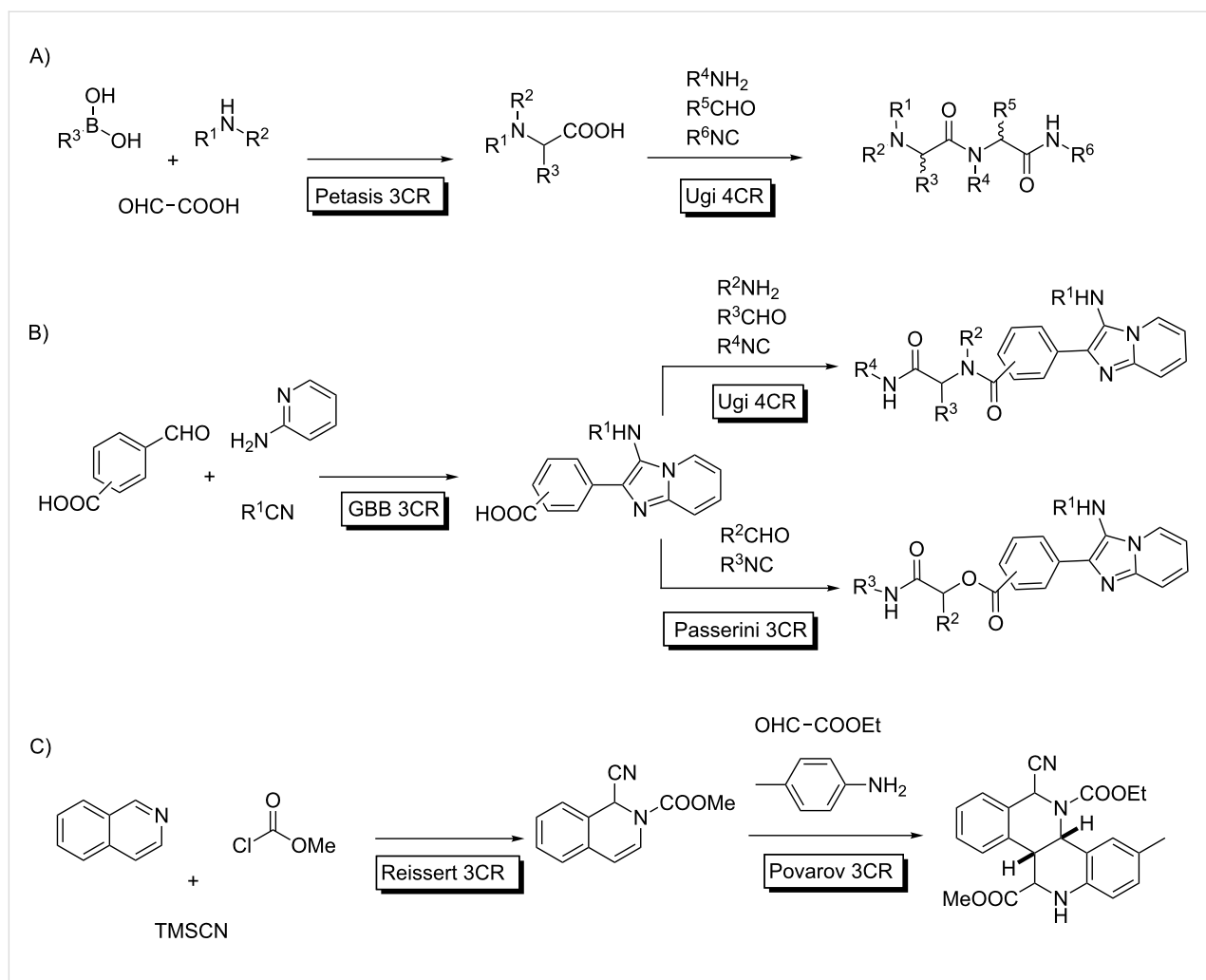
**Scheme 8:** Biased substrates for selective MMCRs.



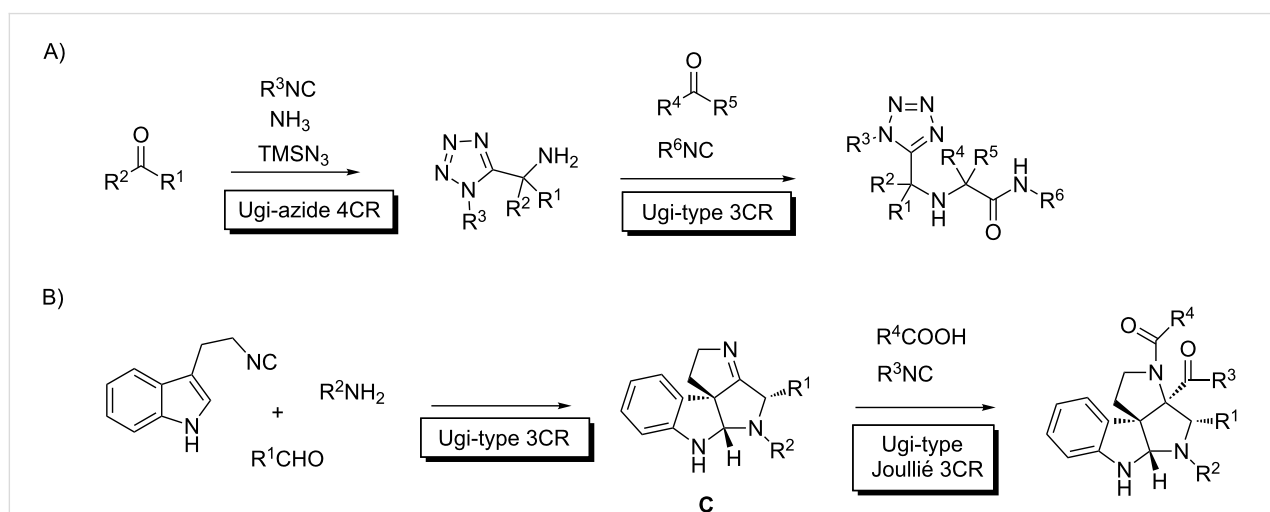
**Scheme 9:** The Union concept. A) Asinger–Ugi combination; B) Passerini–Ugi/azide from anthranilic acid; C) Passerini–Ugi multiple MCR from glutamic acid.

(Scheme 11A). Analogously, Ruijter reported an interrupted Ugi process [46] involving a 2-(3-indolyl)ethyl isocyanide, an aldehyde and an amine which elegantly led to the iminospiro adduct **C** (Scheme 11B). This compound does not react under

the initial reaction conditions, but can be forced to do so in a Joullié MCR with a new isocyanide/carboxylic acid pair [47]. Incidentally, this last process is also remarkably stereoselective, something very unusual in Ugi-type reactions.



**Scheme 10:** Relevant examples of consecutive MCRs exploiting the Union Concept. A) Petasis-Ugi combination; B) GBB-Ugi/Passerini combination; C) Reissert MCRs linked to a Povarov reaction.



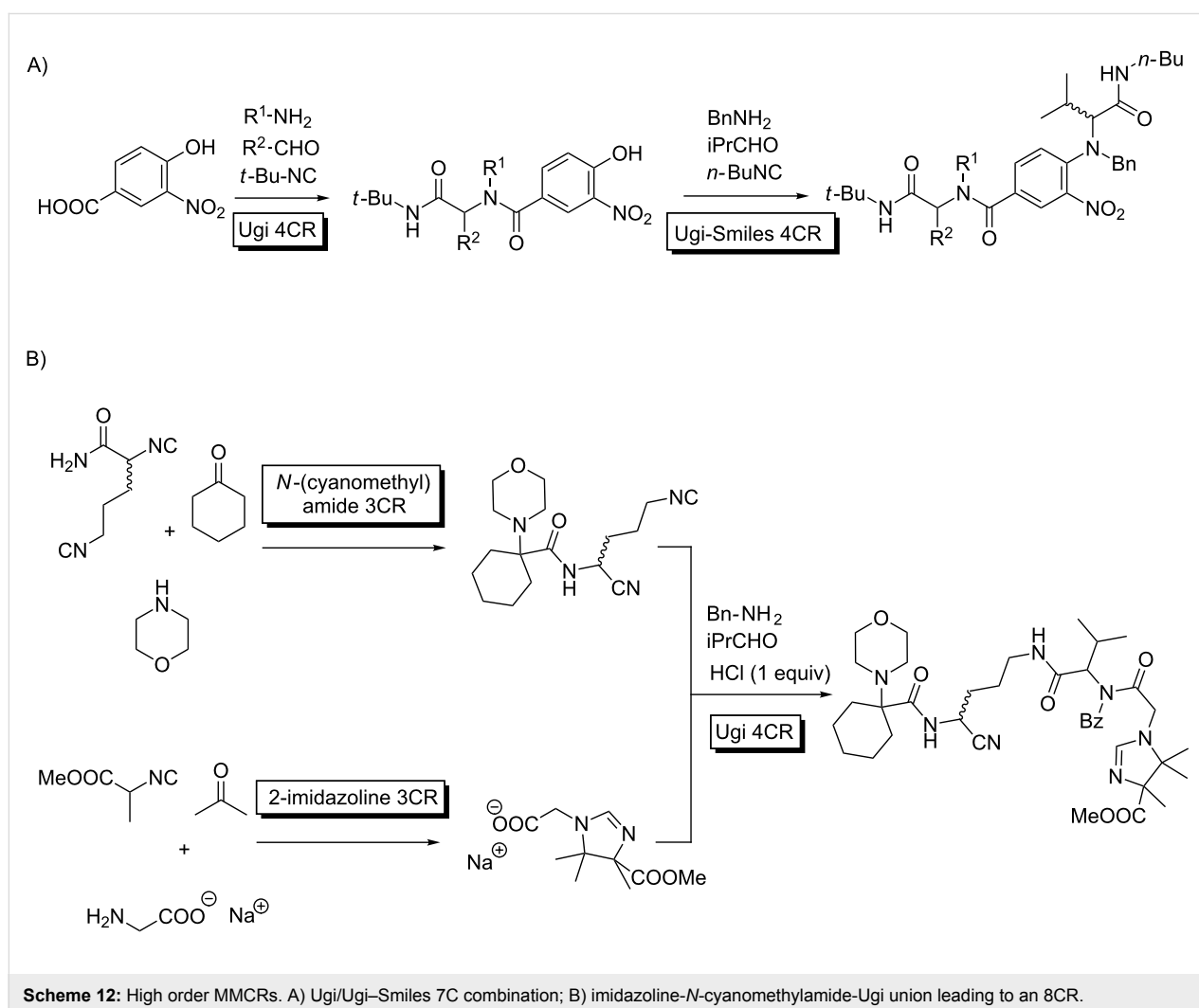
**Scheme 11:** Selective MMCRs featuring FGs with distinct reactivity along the sequence. A) Synthesis of aminomethyltetrazoles by consecutive isocyanide MCRs. B) Interrupted Ugi/Joullié sequence.

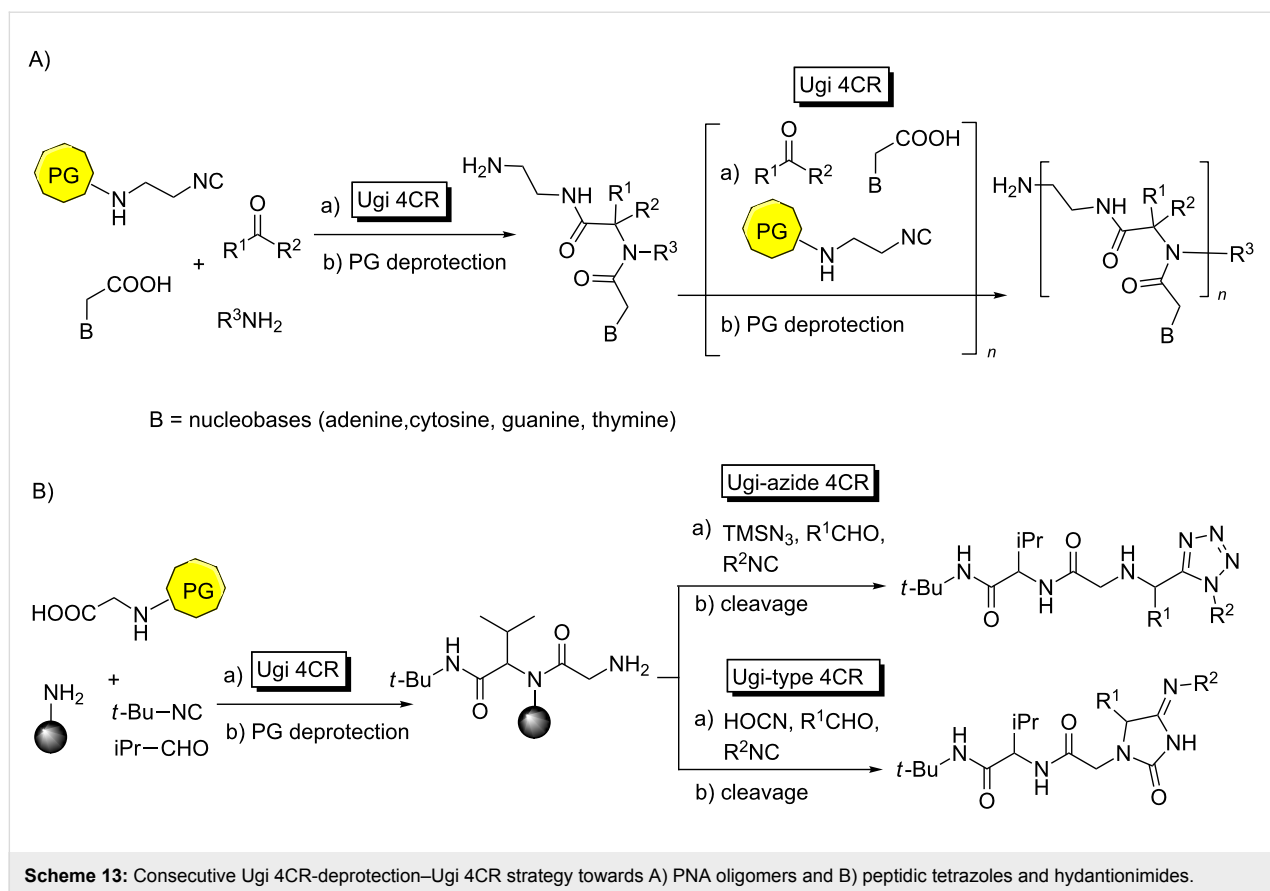
Finally, to exemplify the complexity levels that can be achieved with this approach, we list two multiple MCRs showing their power to reach very elaborate scaffolds with several diversity points in short sequences. Westermann described a remarkable Ugi/Ugi–Smiles protocol using a carboxylic acid provided with a phenol group, which led to a 7-component transformation in a sequential manner (Scheme 12A) [48]. The process can be kinetically justified taking into account that the Ugi MCR with the acid input is much faster than the Ugi–Smiles transformation involving the phenol. In another impressive transformation, a formal 8-component adduct can be assembled through a one-pot protocol combining imidazoline, cyanomethylamide and Ugi MCRs. Although the final product is a complex stereoisomeric mixture, the process stands as a milestone for the rapid construction of complex structures, amenable to combinatorial diversification (Scheme 12B) [32]. Incidentally, the reactivity of the diisocyanide leading to the cyanomethylamide MCR, features a distinct reactivity between the two FGs (see above).

Another scenario involves substrates with different FGs where the selective combination of consecutive MCRs can be carried out by temporarily blocking one of the reactive sites along the process. This sequential approach involves protection/deprotection steps in which one of the building blocks contains a protected FG to be subsequently (and selectively) activated for the following MCRs.

For instance, the examples shown in Scheme 13 illustrate a repetitive Ugi 4CR-deprotection-Ugi 4CR protocol to obtain peptide nucleic acid (PNA) oligomers (Scheme 13A) [49], peptidic tetrazoles and hydantoinimides (Scheme 13B) [50], respectively. Incidentally, the later processes take place in solid phase, which enhances their synthetic suitability.

The same strategy was exploited by Wessjohann for the synthesis of RGD (Arg-Gly-Asp)cyclopeptides [51]. In this case, they developed a stepwise protocol in which two Ugi 4CRs, flanking a deprotection, provided linear peptidic adducts. Afterwards,





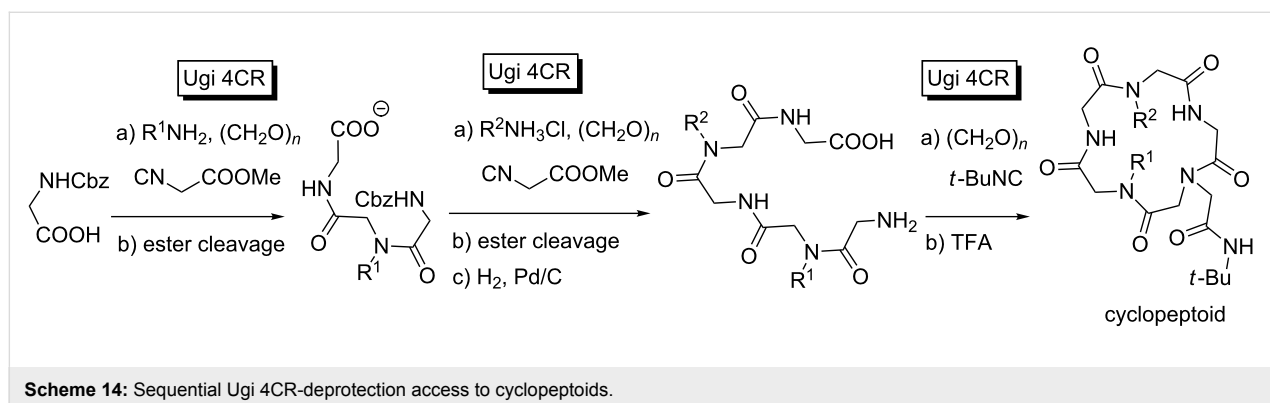
these intermediates were again deprotected and a final Ugi 4CR-macrocyclization efficiently afforded the final target (Scheme 14).

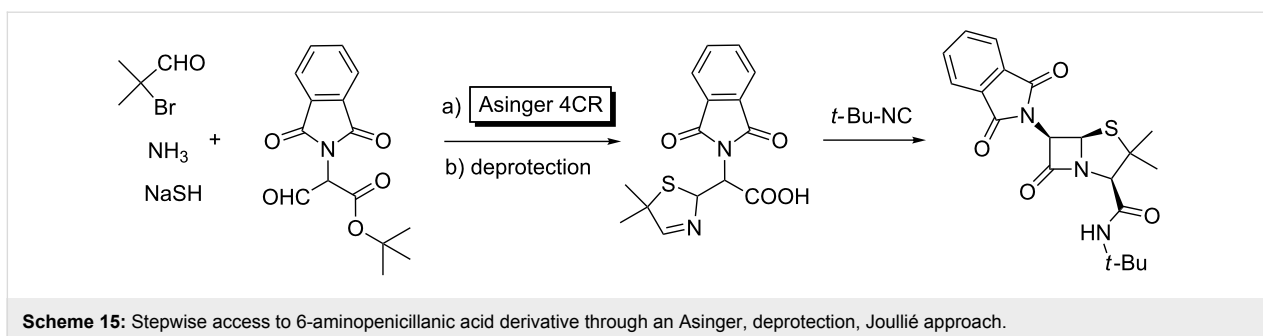
Furthermore, additional sequential versions of multiple MCRs have been employed to construct natural products. For instance, Ugi reported the synthesis of a 6-aminopenicillanic acid derivative using two different MCRs [33,52]. As shown in Scheme 15, the initial Asinger 4CR yielded an adduct which was selectively deprotected for the following intramolecular Joullié reaction, leading to the penam derivative.

Finally, an elegant MCR–deprotection strategy was reported by Wessjohann for the synthesis of Tubugis, highly potent anti-tumor peptidomimetics (Scheme 16) [53]. The convergent approach employs three different isocyanide-MCRs, efficiently prepares the building blocks and combines them, intercalating protecting group cleavages.

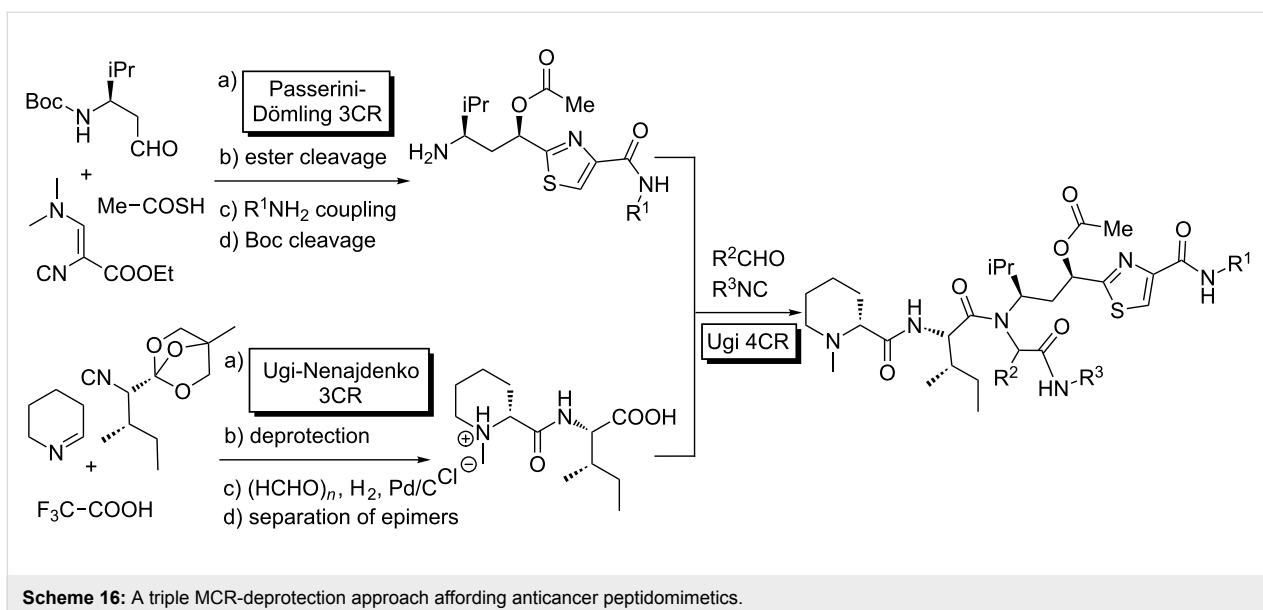
## Conclusion

The MMCRs approach represents the most efficient way to build chemical complexity and structural diversity around meaningful scaffolds. When different sets of reactants are





**Scheme 15:** Stepwise access to 6-aminopenicillanic acid derivative through an Asinger, deprotection, Joullié approach.



**Scheme 16:** A triple MCR-deprotection approach affording anticancer peptidomimetics.

involved in these processes, the control of the selectivity becomes a fundamental issue. In this respect, a variety of scenarios can be considered. Innate selectivity (the spontaneous selection of reactants) is unknown and, arguably, it would be difficult to reach under standard conditions. However, this lack of selectivity allows the generation of complex mixtures of adducts, useful in combinatorial chemistry for biological purposes. On the other hand, MCR polymerization takes advantage of this behaviour, and a variety of transformations lead to well-defined macromolecules. An interesting case is found in systems where the reaction conditions and the preorganization of some inputs leads to selective macrocyclization, affording extremely complex MCR adducts in just one step. Rationalization of these processes allows programmed access to a variety of structural types. On the contrary, when di(poly)functionalized substrates display conjugation between the reactive FGs, selectivity may arise. When the initial MCR adduct is less reactive than the starting material, a sequential procedure may lead to the following transformation with different reactants to afford the final adducts in a selective manner. Alternatively, substrates with two chemically distinct FGs of the same kind (i.e.,

isocyanides) may react at different rates, prompting selectivity, usually in a sequential manner. Moreover, the generation of novel FGs in the course of a given MCR can trigger a new one, then allowing for selectivity in another sequential approach.

Finally, the use of protecting groups in reactants undergoing MCRs leads to multistep transformations which, after suitable deprotections, selectively afford the final adducts. Active research is pursued in the field, aiming at the generalization of the aforementioned concepts and their extension to diverse synthetic outcomes.

## Acknowledgements

Financial support from the Ministerio de Economía y Competitividad-Spain (MINECO, CTQ2015-67870-P) and Generalitat de Catalunya (2017 SGR 1439) is gratefully acknowledged.

## ORCID® iDs

Ouldouz Ghashghaei - <https://orcid.org/0000-0002-5524-3697>

Francesca Seghetti - <https://orcid.org/0000-0003-0478-7341>

Rodolfo Lavilla - <https://orcid.org/0000-0002-5006-9917>

## References

- Wender, P. A.; Verma, V. A.; Paxton, T. J.; Pillow, T. H. *Acc. Chem. Res.* **2008**, *41*, 40–49. doi:10.1021/ar700155p
- Newhouse, T.; Baran, P. S.; Hoffmann, R. W. *Chem. Soc. Rev.* **2009**, *38*, 3010–3021. doi:10.1039/b821200g
- Gaich, T.; Baran, P. S. *J. Org. Chem.* **2010**, *75*, 4657–4673. doi:10.1021/jo1006812
- Zhu, J.; Wang, Q.; Wang, M.-X., Eds. *Multicomponent Reactions in Organic Synthesis*; Wiley-VCH Verlag GmbH: Weinheim, Germany, 2014. doi:10.1002/9783527678174
- Wessjohann, L. A.; Neves Filho, R. A. W.; Rivera, D. G. Multiple Multicomponent Reactions with Isocyanides. In *Isocyanide Chemistry: Applications in Synthesis and Material Science*; Nenajdenko, V., Ed.; Wiley-VCH Verlag GmbH: Weinheim, 2012; pp 233–262. doi:10.1002/9783527652532.ch7  
See for an overview.
- Ugi, I.; Goebel, M.; Gruber, B.; Heilingbrunner, M.; Heiß, C.; Hörl, W.; Kern, O.; Starnecker, M.; Dömling, A. *Res. Chem. Intermed.* **1996**, *22*, 625–644. doi:10.1163/156856796x00115  
See for an early example.
- Mayr, H. *Tetrahedron* **2015**, *71*, 5095–5111. doi:10.1016/j.tet.2015.05.055  
See for a review on this topic.
- Yoshida, S.; Kanno, K.; Kii, I.; Misawa, Y.; Hagiwara, M.; Hosoya, T. *Chem. Commun.* **2018**, *54*, 3705–3708. doi:10.1039/c8cc01195h  
See for an analogy in a simpler system involving standard bicomponent reactions.
- Kakuchi, R. *Angew. Chem., Int. Ed.* **2014**, *53*, 46–48. doi:10.1002/anie.201305538
- Llevot, A.; Boukis, A. C.; Oelmann, S.; Wetzel, K.; Meier, M. A. R. *Top. Curr. Chem.* **2017**, *375*, 66. doi:10.1007/s41061-017-0153-4
- Zhang, Z.; You, Y.; Hong, C. *Macromol. Rapid Commun.* **2018**, *39*, 1800362. doi:10.1002/marc.201800362
- Xue, H.; Zhao, Y.; Wu, H.; Wang, Z.; Yang, B.; Wei, Y.; Wang, Z.; Tao, L. *J. Am. Chem. Soc.* **2016**, *138*, 8690–8693. doi:10.1021/jacs.6b04425
- Zhang, J.; Wu, Y.-H.; Wang, J.-C.; Du, F.-S.; Li, Z.-C. *Macromolecules* **2018**, *51*, 5842–5851. doi:10.1021/acs.macromol.8b01168
- Hartweg, M.; Becer, C. R. *Green Chem.* **2016**, *18*, 3272–3277. doi:10.1039/c6gc00372a
- Yoon, K.-Y.; Dong, G. *Angew. Chem., Int. Ed.* **2018**, *57*, 8592–8596. doi:10.1002/anie.201804116
- Kim, H.; Choi, T.-L. *ACS Macro Lett.* **2014**, *3*, 791–794. doi:10.1021/mz5003239
- Tian, T.; Hu, R.; Tang, B. Z. *J. Am. Chem. Soc.* **2018**, *140*, 6156–6163. doi:10.1021/jacs.8b02886
- Wessjohann, L. A.; Rivera, D. G.; Vercillo, O. E. *Chem. Rev.* **2009**, *109*, 796–814. doi:10.1021/cr8003407
- Rivera, D. G.; Wessjohann, L. A. *J. Am. Chem. Soc.* **2009**, *131*, 3721–3732. doi:10.1021/ja809005k
- Wessjohann, L. A.; Ruijter, E. *Mol. Diversity* **2005**, *9*, 159–169. doi:10.1007/s11030-005-1313-y
- Wessjohann, L. A.; Kreye, O.; Rivera, D. G. *Angew. Chem., Int. Ed.* **2017**, *56*, 3501–3505. doi:10.1002/anie.201610801
- Wessjohann, L. A.; Rivera, D. G.; León, F. *Org. Lett.* **2007**, *9*, 4733–4736. doi:10.1021/ol7021033
- Rivera, D. G.; Wessjohann, L. A. *J. Am. Chem. Soc.* **2006**, *128*, 7122–7123. doi:10.1021/ja060720r
- Rivera, D. G.; León, F.; Concepción, O.; Morales, F. E.; Wessjohann, L. A. *Chem. – Eur. J.* **2013**, *19*, 6417–6428. doi:10.1002/chem.201201591
- Ricardo, M. G.; Morales, F. E.; Garay, H.; Reyes, O.; Vasilev, D.; Wessjohann, L. A.; Rivera, D. G. *Org. Biomol. Chem.* **2015**, *13*, 438–446. doi:10.1039/c4ob01915f
- Masson, G.; Neuville, L.; Bughin, C.; Fayol, A.; Zhu, J. In *Synthesis of Heterocycles via Multicomponent Reactions II*; Orru, R. V. A.; Ruijter, E., Eds.; Topics in Heterocyclic Chemistry; Springer: Berlin, Heidelberg, 2010; pp 1–24.
- Leon, F.; Rivera, D. G.; Wessjohann, L. A. *J. Org. Chem.* **2008**, *73*, 1762–1767. doi:10.1021/jo7022125
- Christinat, N.; Scopelliti, R.; Severin, K. *J. Org. Chem.* **2007**, *72*, 2192–2200. doi:10.1021/jo062607p
- Shahrisa, A.; Esmati, S. *Synlett* **2013**, *24*, 595–602. doi:10.1055/s-0032-1318221
- Kaur, T.; Gautam, R. N.; Sharma, A. *Chem. – Asian J.* **2016**, *11*, 2938–2945. doi:10.1002/asia.201601009
- Ghashghaei, O.; Caputo, S.; Sintes, M.; Revés, M.; Kielland, N.; Estarellas, C.; Luque, F. J.; Aviñó, A.; Eritja, R.; Serna-Gallego, A.; Marrugal-Lorenzo, J. A.; Pachón, J.; Sánchez-Céspedes, J.; Treadwell, R.; de Moliner, F.; Vendrell, M.; Lavilla, R. *Chem. – Eur. J.* **2018**, *24*, 14513–14521. doi:10.1002/chem.201802877
- Elders, N.; van der Born, D.; Hendrickx, L. J. D.; Timmer, B. J. J.; Krause, A.; Janssen, E.; de Kanter, F. J. J.; Ruijter, E.; Orru, R. V. A. *Angew. Chem., Int. Ed.* **2009**, *48*, 5856–5859. doi:10.1002/anie.200902683
- Zarganes-Tzitzikas, T.; Chandgude, A. L.; Dömling, A. *Chem. Rec.* **2015**, *15*, 981–996. doi:10.1002/tcr.201500201
- Brauch, S.; van Berkel, S. S.; Westermann, B. *Chem. Soc. Rev.* **2013**, *42*, 4948–4962. doi:10.1039/c3cs35505e
- Dömling, A.; Ugi, I. *Angew. Chem., Int. Ed. Engl.* **1993**, *32*, 563–564. doi:10.1002/anie.199305631
- Ugi, I. K.; Ebert, B.; Hörl, W. *Chemosphere* **2001**, *43*, 75–81. doi:10.1016/s0045-6535(00)00326-x
- Ugi, I.; Demharter, A.; Hörl, W.; Schmid, T. *Tetrahedron* **1996**, *52*, 11657–11664. doi:10.1016/0040-4020(96)00647-3
- Portlock, D. E.; Ostaszewski, R.; Naskar, D.; West, L. *Tetrahedron Lett.* **2003**, *44*, 603–605. doi:10.1016/s0040-4039(02)02619-9
- Al-Tel, T. H.; Al-Qawasmeh, R. A.; Voelter, W. *Eur. J. Org. Chem.* **2010**, 5586–5593. doi:10.1002/ejoc.201000808
- Lavilla, R.; Carranco, I.; Díaz, J. L.; Bernabeu, M. C.; de la Rosa, G. *Mol. Diversity* **2003**, *6*, 171–175. doi:10.1023/b:modi.0000006756.83821.80
- Bienaymé, H. *Tetrahedron Lett.* **1998**, *39*, 4255–4258. doi:10.1016/s0040-4039(98)00696-0
- Scheffelaar, R.; Klein Nijenhuis, R. A.; Paravidino, M.; Lutz, M.; Spek, A. L.; Ehlers, A. W.; de Kanter, F. J. J.; Groen, M. B.; Orru, R. V. A.; Ruijter, E. *J. Org. Chem.* **2009**, *74*, 660–668. doi:10.1021/jo802052j
- Coffinier, D.; El Kaïm, L.; Grimaud, L.; Ruijter, E.; Orru, R. V. A. *Tetrahedron Lett.* **2011**, *52*, 3023–3025. doi:10.1016/j.tetlet.2011.04.007
- Kröger, D.; Stalling, T.; Martens, J. *Synthesis* **2016**, *48*, 4189–4198. doi:10.1055/s-0035-1562457
- Patil, P.; Mishra, B.; Sheombarsing, G.; Kurpiowska, K.; Kalinowska-Tłuścik, J.; Dömling, A. *ACS Comb. Sci.* **2018**, *20*, 70–74. doi:10.1021/acscombsci.7b00137

46. Giustiniano, M.; Moni, L.; Sangaletti, L.; Pelliccia, S.; Basso, A.; Novellino, E.; Tron, G. C. *Synthesis* **2018**, *50*, 3549–3570. doi:10.1055/s-0037-1610193  
See for a review.
47. Saya, J. M.; Oppelaar, B.; Cioc, R. C.; van der Heijden, G.; Vande Velde, C. M. L.; Orru, R. V. A.; Ruijter, E. *Chem. Commun.* **2016**, *52*, 12482–12485. doi:10.1039/c6cc07459f
48. Brauch, S.; Gabriel, L.; Westermann, B. *Chem. Commun.* **2010**, *46*, 3387–3389. doi:10.1039/b927388c
49. Dömling, A.; Chi, K.-Z.; Barrère, M. *Bioorg. Med. Chem. Lett.* **1999**, *9*, 2871–2874. doi:10.1016/s0960-894x(99)00491-6
50. Constabel, F.; Ugi, I. *Tetrahedron* **2001**, *57*, 5785–5789. doi:10.1016/s0040-4020(01)00516-6
51. Vercillo, O. E.; Andrade, C. K. Z.; Wessjohann, L. A. *Org. Lett.* **2008**, *10*, 205–208. doi:10.1021/ol702521g
52. Ugi, I. *Angew. Chem., Int. Ed. Engl.* **1982**, *21*, 810–819. doi:10.1002/anie.198208101
53. Pando, O.; Stark, S.; Denkert, A.; Porzel, A.; Preusentanz, R.; Wessjohann, L. A. *J. Am. Chem. Soc.* **2011**, *133*, 7692–7695. doi:10.1021/ja2022027

## License and Terms

This is an Open Access article under the terms of the Creative Commons Attribution License (<http://creativecommons.org/licenses/by/4.0>). Please note that the reuse, redistribution and reproduction in particular requires that the authors and source are credited.

The license is subject to the *Beilstein Journal of Organic Chemistry* terms and conditions: (<https://www.beilstein-journals.org/bjoc>)

The definitive version of this article is the electronic one which can be found at:  
[doi:10.3762/bjoc.15.46](https://doi.org/10.3762/bjoc.15.46)



# Catalyst-free assembly of giant tris(heteroaryl)methanes: synthesis of novel pharmacophoric triads and model sterically crowded tris(heteroaryl/aryl)methyl cation salts

Rodrigo Abonia<sup>1</sup>, Luisa F. Gutiérrez<sup>1,2</sup>, Braulio Insuasty<sup>1</sup>, Jairo Quiroga<sup>1</sup>, Kenneth K. Laali<sup>\*2</sup>, Chunqing Zhao<sup>2</sup>, Gabriela L. Borosky<sup>3</sup>, Samantha M. Horwitz<sup>4</sup> and Scott D. Bunge<sup>4</sup>

## Full Research Paper

[Open Access](#)

### Address:

<sup>1</sup>Research Group of Heterocyclic Compounds (GICH), Department of Chemistry, Universidad del Valle, A. A. 25360, Cali, Colombia, <sup>2</sup>Department of Chemistry, University of North Florida, 1 UNF Drive, Jacksonville, FL 32224, USA, <sup>3</sup>INFIQC, CONICET and Departamento de Química Teórica y Computacional, Facultad de Ciencias Químicas, Universidad Nacional de Córdoba, Ciudad Universitaria, Córdoba 5000, Argentina and <sup>4</sup>Department of Chemistry and Biochemistry, Kent State University, Kent, OH 44242, USA

### Email:

Kenneth K. Laali<sup>\*</sup> - Kenneth.Laali@UNF.edu

<sup>\*</sup> Corresponding author

### Keywords:

model heteroaryl/methyl cation salts; multicomponent; one-pot catalyst-free assembly; pharmacophoric triads; three-component synthesis; tris(heteroaryl)methanes; Yonemitsu-type reaction

*Beilstein J. Org. Chem.* **2019**, *15*, 642–654.

doi:10.3762/bjoc.15.60

Received: 06 December 2018

Accepted: 26 February 2019

Published: 12 March 2019

This article is part of the thematic issue "Multicomponent reactions III".

Guest Editor: T. J. J. Müller

© 2019 Abonia et al.; licensee Beilstein-Institut.

License and terms: see end of document.

## Abstract

A series of giant tris(heteroaryl)methanes are easily assembled by one-pot three-component synthesis by simple reflux in ethanol without catalyst or additives. Diversely substituted indoles ( $\text{Ar}^1$ ) react with quinoline aldehydes, quinolone aldehydes, chromone aldehydes, and fluorene aldehydes ( $\text{Ar}^2\text{CHO}$ ) and coumarins ( $\text{Ar}^3$ ) in 1:1:1 ratio to form the corresponding tris(heteroaryl)methanes ( $\text{Ar}^1\text{Ar}^2\text{Ar}^3\text{CH}$ ) along with ( $\text{Ar}^1\text{Ar}^1\text{Ar}^2\text{CH}$ ) triads. A series of new 2:1 triads were also synthesized by coupling substituted indoles with  $\text{Ar}^2\text{CHO}$ . The coupling reactions could also be carried out in water (at circa 80 °C) but with chemoselectivity favoring ( $\text{Ar}^1\text{Ar}^1\text{Ar}^2\text{CH}$ ) over ( $\text{Ar}^1\text{Ar}^2\text{Ar}^3\text{CH}$ ). The molecular structure of a representative ( $\text{Ar}^1\text{Ar}^2\text{Ar}^3\text{CH}$ ) triad was confirmed by X-ray analysis. Model tris(heteroaryl/aryl)methyl cation salts were generated by reaction with DDQ/HPF<sub>6</sub> and studied by NMR and by DFT and GIAO-DFT.

## Introduction

During the last few decades multicomponent reactions (MCRs) have gained importance as a suitable strategy for the synthesis of diverse synthetic and naturally occurring compounds of bio-

logical and practical interest. This approach offers several advantages including simplicity, high reaction rates, and high bond-forming efficiency [1-5]. Furthermore, it is highly desir-

able to perform these reactions in environmentally friendly solvents such as water, ethanol, and PEG [6,7].

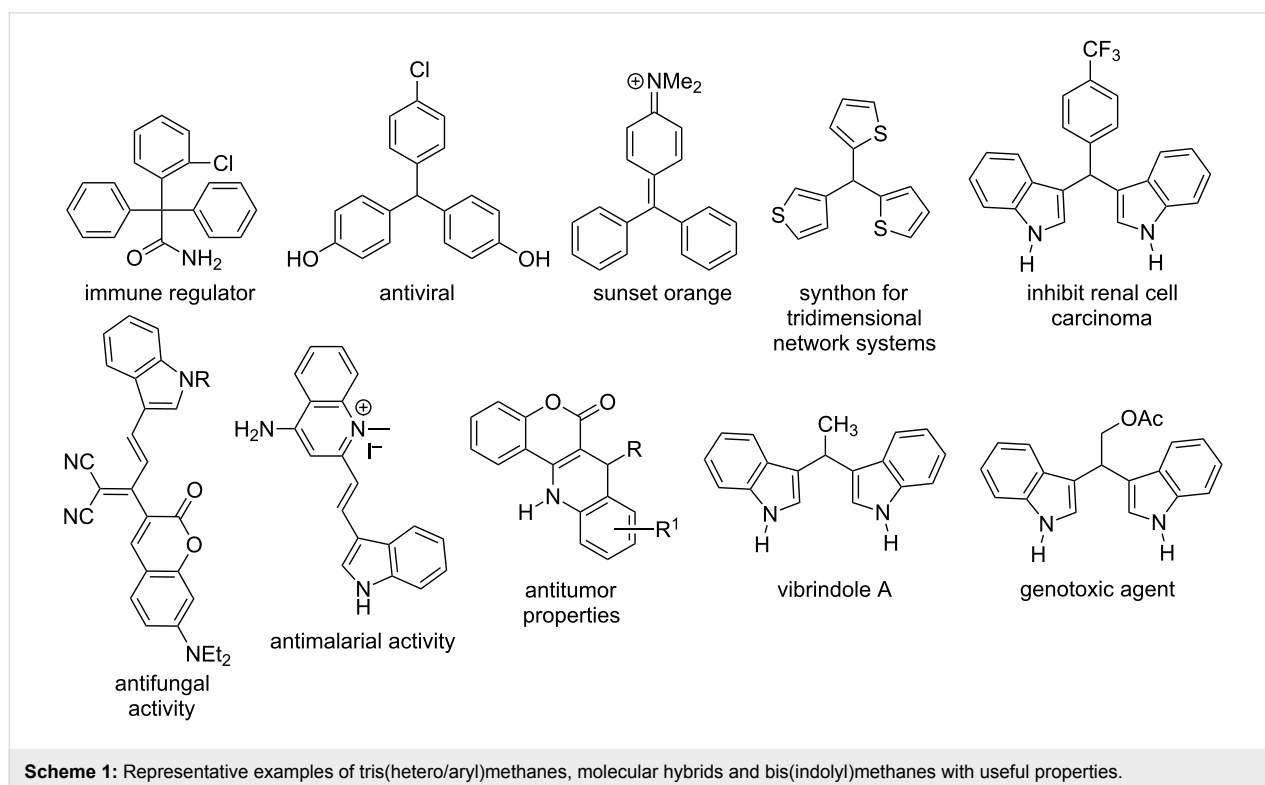
Motifs bearing triarylmethane ( $\text{Ar}_3\text{CH}$ ) [8-10] and their heterocyclic variants ( $\text{Het-Ar}$ ) $_3\text{CH}$  [8-12], constitute an integral part of a number of bioactive compounds [13-16]. Due to their valuable properties, they are also well exploited by the chemical industry as dyes and photochromic agents [17,18], protective groups in organic synthesis [19] and as building blocks for dendrimers [20] and nonlinear optical (NLO) properties [21] (Scheme 1). Numerous methods for the construction of triarylmethane frameworks have been developed, with the majority of them bearing simple diaryl or triaryl moieties in their structures [22], and many are performed in multistep processes or require harsh reaction conditions [1-22]. Although, “Yonemitsu-type” three-component reactions have been employed for the synthesis of indole-based triarylmethanes [23-26] (Scheme 2), there still exists a need for the development of new approaches for easy access to libraries of triarylmethanes of higher complexity by employing simpler, more efficient, catalytic methods that are also environmentally friendly.

Molecular hybridization has emerged as an interesting strategy for the synthesis of bioactive molecules with improved properties by combining two or more pharmacophore fragments in a new structure. This concept has recently received attention by the pharmaceutical industry because it provides new options to

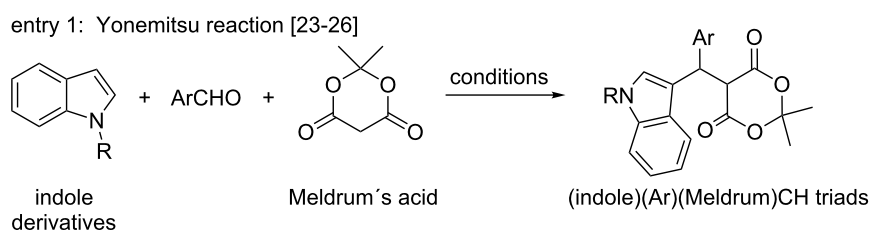
develop more specific drugs for the treatment of persistent and challenging pathologies [27,28] (Scheme 1).

The indole, coumarin, quinoline, chromone and fluorene moieties are a set of “privileged structural motifs” that are present in both synthetic and naturally occurring compounds of practical and biological interest [29-36]. Consequently, there have been many attempts to produce hybrid structures with interesting properties by combining two such pharmacophores in one molecule, using both catalytic and non-catalytic reactions [37-48].

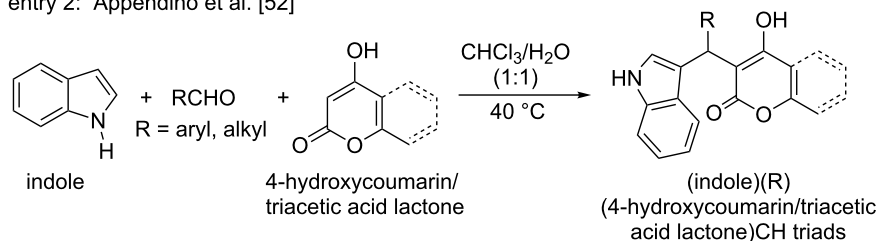
However, a remaining challenge is to discover methods to construct asymmetric triads consisting of three different pharmacophores (i.e., heterodimeric entities) via a simple synthetic step. According to the literature, most attempts in this direction have resulted in isolation of symmetric and asymmetric bis(indolyl)methane derivatives as the main components [39-41,49-52] (Scheme 1). Some exceptions to this tendency have been reported by Appendino et al. [52] and by Mousavizadeh et al. [53] through the three-component reactions of indole and coumarin, but in all cases, ordinary aliphatic and aromatic aldehydes as the third partner, mediated by a catalyst or by a biphasic system as solvent, respectively, were used. The lack of structural diversity in the indole and coumarin partners also characterizes these approaches, Scheme 2.



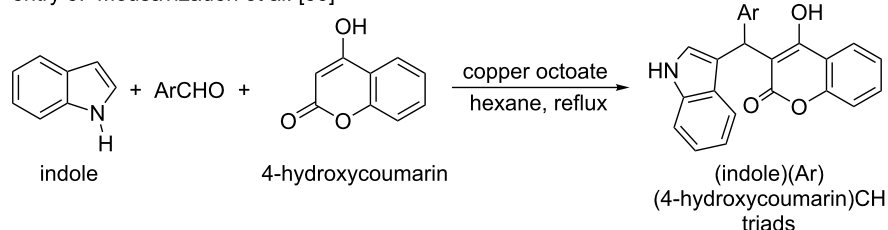
## previous work



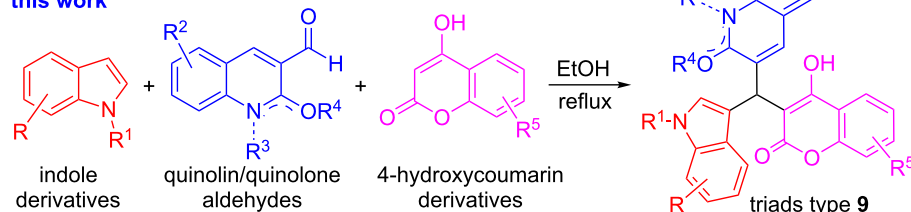
entry 2: Appendino et al. [52]



entry 3: Mousavizadeh et al. [53]



## this work



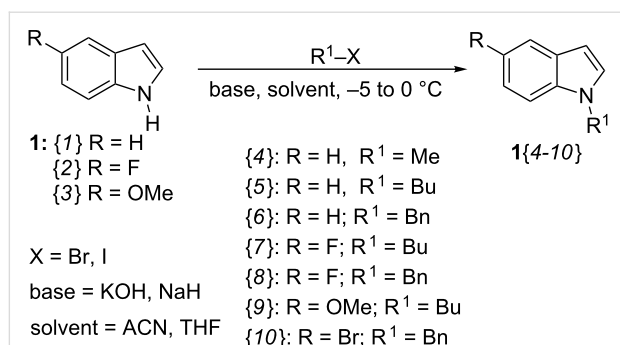
Scheme 2: Previous synthetic approaches for the synthesis of triarylmethane analogues in comparison to the present study.

Continuing our current program on the synthesis of quinoline-based heterocyclic compounds of biological interest [54–57], we describe here a Yonemitsu-based direct and reproducible three-component synthesis of ternary heteroarylmethane-inspired hybrids by coupling diversely substituted indoles ( $\text{Ar}^1$ ) with quinoline aldehydes, quinolone aldehydes, chromone aldehydes, and fluorene aldehydes ( $\text{Ar}^2\text{CHO}$ ) and coumarins ( $\text{Ar}^3$ ) in 1:1:1 ratio by simple reflux in ethanol solvent to form the corresponding highly crowded tris(heteroaryl)methanes ( $\text{Ar}^1\text{Ar}^2\text{Ar}^3\text{CH}$ ) (Scheme 2). Formation of ( $\text{Ar}^1\text{Ar}^1\text{Ar}^2$ )CH triads is a competing process, whose relative proportion varies depending on the choice of the substituents. The efficacy to perform these remarkable reactions in water as solvent, and to generate highly crowded triarylmethyl cations by hydride abstraction from ( $\text{Ar}^1\text{Ar}^1\text{Ar}^2$ )CH are also demonstrated.

## Results and Discussion

At the onset a series of non-commercial *N*-alkylindoles **1**{4–10} and quinoline-/quinolone aldehydes **6**{1–7} were prepared (Scheme 3 and Scheme 4). The *N*-methyl-, *N*-butyl- and *N*-benzylindoles **1**{4–10} were synthesized in 80–98% yield by *N*-alkylation of commercially available *N*-H indoles **1**{1–3} ({1} R = H; {2} R = F and {3} R = OMe), by adopting a procedure similar to that described by Kong et al. [58] (Scheme 3).

The quinolone aldehydes **5** were synthesized via 2-chloroquinoline-3-carbaldehydes **4** mediated by a Meth-Cohn type methodology through the Vilsmeier–Haack (DMF +  $\text{POCl}_3$ ) reagent [59,60]. A subsequent sequence of hydrolysis and *N/O*-alkylation processes, respectively, afforded the starting quinoline-/



**Scheme 3:** Synthesis of the starting *N*-alkylindoles **1**{4–10}.

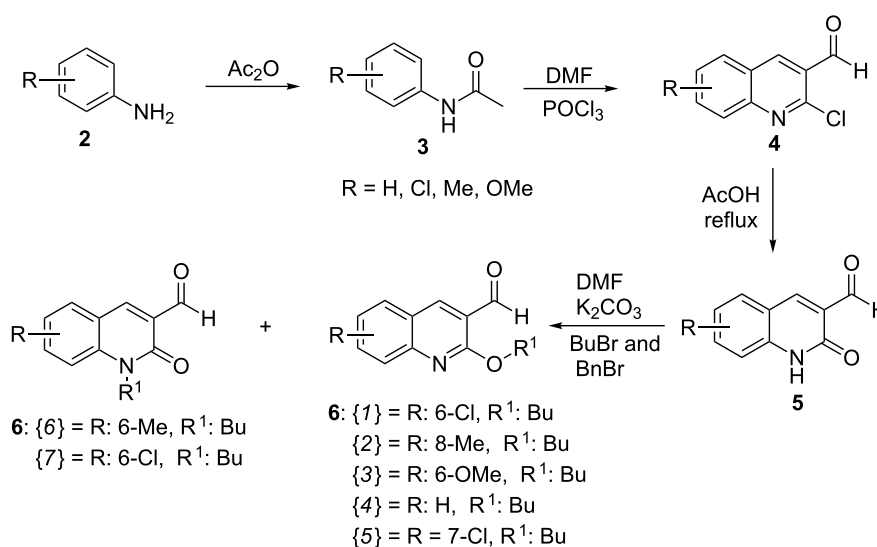
quinolone aldehydes **6**{1–7} in 70–85% yield as described previously [54] (Scheme 4).

Additionally, a chemset of hydroxycoumarins **7**{1–4} (Scheme 5) was chosen as the second source of nucleophilic partners for elaboration in our MCR experiments.

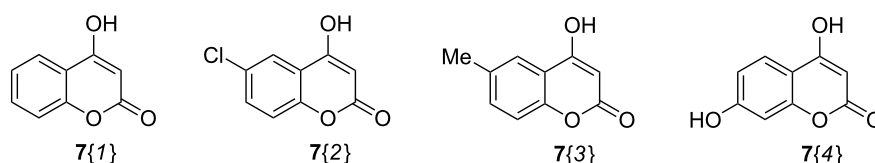
With these building blocks at hand, an initial three-component assay was performed starting with indole **1**{1} (1.0 equiv),

quinoline aldehyde **6**{1} (1.0 equiv) and coumarin **7**{1} (1.0 equiv) in ethanol as solvent with no catalyst. The mixture was subjected to stirring at ambient temperature, and the reaction progress was monitored by TLC. After 24 h, the starting materials **1**{1} and **6**{1} were almost totally consumed, but several spots were observed (including unreacted **7**{1}), with two of them as main components. A white solid fell out of solution, which was collected by filtration and washed with cold ethanol. NMR and HRMS analysis showed that it corresponded to the bisindole derivative **8**{1,1,1}. The remaining crude reaction mixture was purified by column chromatography, and led to isolation of a second major component corresponding to the desired three-component product **9**{1,1,1}. The relative weight ratios of the two isolated products **8**{1,1,1} and **9**{1,1,1} were circa 1:1 (Scheme 6).

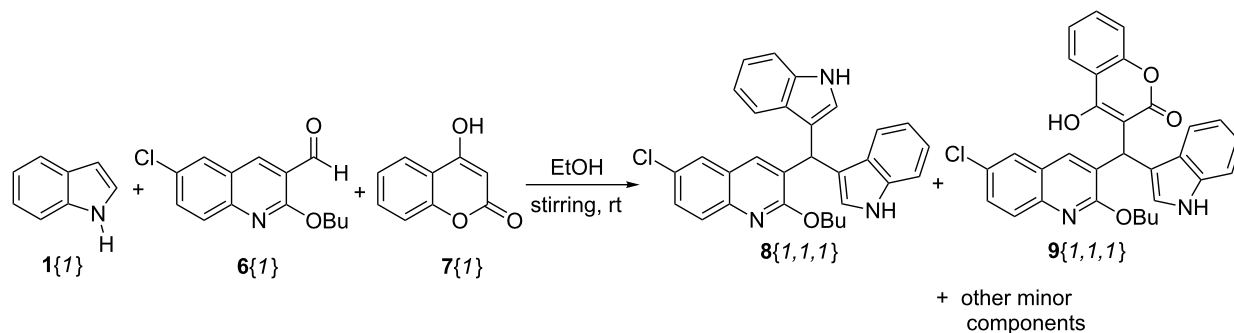
These initial findings encouraged us to perform an in-depth study aimed at optimizing chemoselectivity. As a model reaction, an equimolar three-component mixture of precursors **1**{1}, **6**{2} and **7**{1} was subjected to various catalyzed and uncatalyzed conditions and the results are summarized in Table 1.



**Scheme 4:** General procedure for the synthesis of the starting quinoline/quinolone aldehydes **6**{1–7}.



**Scheme 5:** Chemset of coumarins **7**{1–4} for elaboration in the MCR experiments.



**Scheme 6:** Exploratory reaction leading to isolation of products **8{1,1,1}** and **9{1,1,1}**.

**Table 1:** Optimization of the reaction conditions for the three-component synthesis of triads **8{1,1,2}** and **9{1,2,1}**.

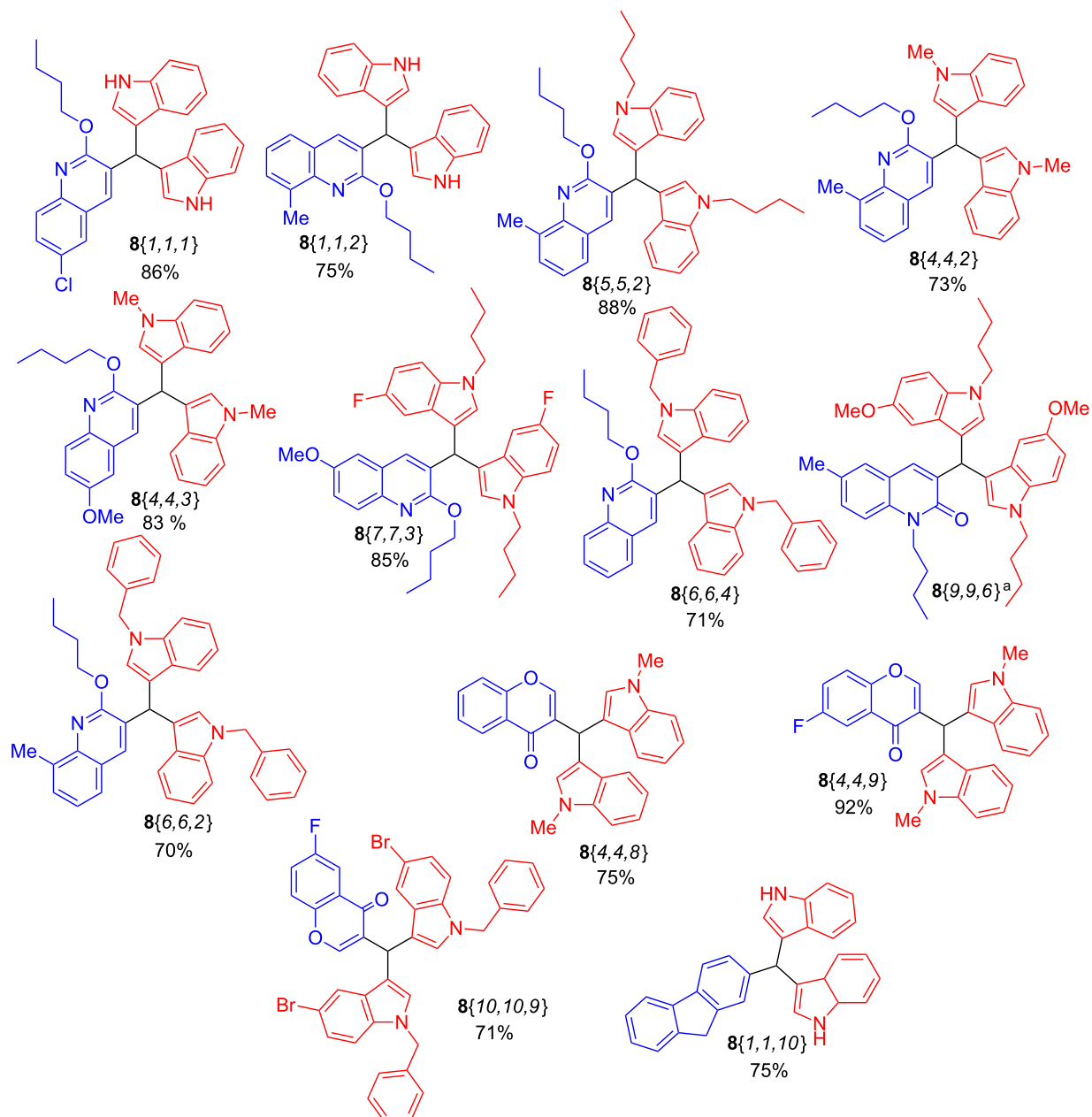
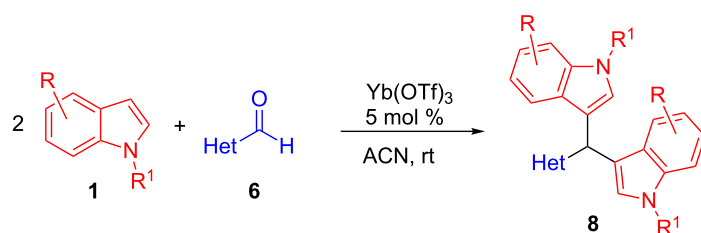
entry <sup>a</sup>	solvent (2 mL)	catalyst (mol %)	temp. (°C)	time (h)	bisindole triad <b>8{1,1,2}</b> (% w/w)	tris-triad <b>9{1,2,1}</b> (% w/w)
1	EtOH	–	rt	24	≈50	≈50
2	EtOH	–	reflux	3	≈50	≈50
3	ACN	Yb(OTf) <sub>3</sub> (5)	rt	6	100	–
4	ACN	Sc(OTf) <sub>3</sub> (5)	rt	3	100	–
5	ACN	Al(OTf) <sub>3</sub> (5)	rt	3	100	–
6	ACN	Bi(OTf) <sub>3</sub> (5)	rt	3	100	–
7	ACN	I <sub>2</sub> (5)	rt	1	100	–
8	ACN	BF <sub>3</sub> ·OEt (5)	rt	2	100	–
9	ACN	–	rt	48	≈50	≈50
10	EtOH <sup>b</sup>	AcOH (0.5 mL)	rt	8	≈50	≈50
11	H <sub>2</sub> O	–	reflux	3	≈67	≈33

<sup>a</sup>All reactions were performed starting with compound **1{1}** (10 mg), **6{2}** (20 mg) and **7{1}** (13 mg) corresponding to a 1:1:1 mmolar ratio. <sup>b</sup>1.5 mL of EtOH was used.

Further studies showed that the Lewis acid-catalyzed reactions (Table 1, entries 3–8) greatly favored the formation of bisindole triad **8{1,1,2}**, while EtOH at room temperature produced an optimal (circa 1:1 w/w) mixture of **8{1,1,2}** and **9{1,2,1}** (Table 1, entry 1), and reflux accelerated the process without affecting the w/w ratio (Table 1, entry 2). The reaction time was notably shorter in EtOH at rt in the presence of AcOH as catalyst (Table 1, entry 10), while longer reaction times were noted when MeCN was used as solvent at rt (compare entry 9 and

entry 1). Finally, performing the reaction in hot water instead of EtOH resulted in a 2:1 mixture of **8** and **9**.

Using the outcomes in Table 1 as a guide, an adaptation of entry 3 was chosen to obtain a library of diversely substituted bisindole triads **8**. Since coumarin **7** remained unreacted in this approach the examples described in Figure 1 were performed by employing a 2:1 ratio of precursors **1** and **6**, respectively, in the absence of coumarin **7**.



**Figure 1:** Pseudo-three-component synthesis of bisindole triads **8** employing quinoline-/quinolone-CHO **6**{1–6}, chromone-CHO **6**{8–9} and fluorene-CHO **6**{10} as coupling partners. Although entries 4 and 7 (Table 1) were satisfactory, reactions of Figure 1 were performed by following an adaptation of entry 3 (using Yb(OTf)<sub>3</sub> with a 2:1 ratio of **1** and **6**, respectively) due to lower catalyst cost (in comparison with Sc(OTf)<sub>3</sub>) and/or easier work-up (in comparison with I<sub>2</sub>) (see experimental section). <sup>a</sup>This product was obtained as an inseparable mixture along compound **9**{9,6,2} from the approach described in entry 2 of Table 1 (see also Supporting Information File 1).

For a broader scope of this approach, bisindole triads **8**{4,4,8}, **8**{4,4,9}, **8**{10,10,9} and **8**{1,1,10} were also synthesized in good yields by replacing the corresponding quinoline-/quinolone aldehydes **6**{1–6} with 4-oxo-4*H*-chromene-3-carbaldehyde (**6**{8}), 6-fluoro-4-oxo-4*H*-chromene-3-carbaldehyde (**6**{9}), and 9*H*-fluorene-2-carbaldehyde (**6**{10}), respectively (Scheme 7 and Figure 1).

Focusing our attention on the synthesis of diversely substituted tris(heteroaryl)methane triads of type **9** via a three-component procedure, the approach described in Table 1, entry 2 was adopted, and the method was extended to a variety of indoles **1**, quinoline-/quinolone- and chromene aldehydes **6**, and hydroxycoumarins **7** as illustrated in Schemes 3–5, leading to a set of novel tris(heteroaryl)methane triads **9**{1,1,1} to **9**{6,4,1}, as shown in Figure 2.

Structures of the newly obtained triads **8** and **9** were ascertained by 1D and 2D NMR spectroscopy and by EIMS, elemental analysis, and HRMS (see experimental section and Supporting Information File 1). Additionally, single crystals of compound **9**{4,7,1} suitable for X-ray analysis were grown from ACN at room temperature. Compound **9**{4,7,1} crystallizes in the triclinic space group  $P\bar{1}$  (Figure 3). The asymmetric unit corresponds to one molecule of **9**{4,7,1} and one molecule of ACN. A packing diagram is shown in Figure S1 (Supporting Information File 1). Interestingly, the unit cell consists of a pair of enantiomers. Within the structure of **9**{4,7,1}, there is a short distance between the quinolone carbonyl and the OH of hydroxycoumarin (H(1)–O(4) 1.740 Å).

The DFT-optimized structure of **9**{4,7,1} (Figure 4) confirms the formation of a highly stable hydrogen bond between the quinolone carbonyl and the OH of hydroxycoumarin, with a O⋯H bond distance of 1.603 Å. It should be noted that the hydrogen-bonded conformation is ca. 15 kcal/mol more stable than other rotamers that do not present this O⋯H interaction.

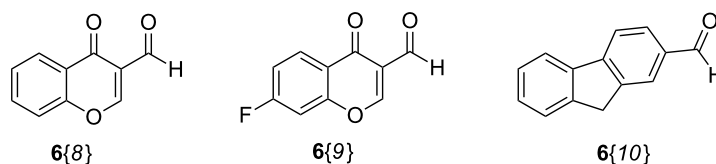
In the next phase of the study the possibility to synthesize crowded tris(heteroaryl/aryl)methylum salts from **8**{4,4,8} and **8**{4,4,11} was examined. Whereas attempts to cleanly generate the salts by hydride abstraction with trityl-BF<sub>4</sub> were unsuccessful

[61], presumably due to extreme steric crowding, the reaction with DDQ/HPF<sub>6</sub> (Scheme 8) [62–65] was successful and the methylum-PF<sub>6</sub> salts **10**{4,4,8} and **10**{4,4,11}, respectively, precipitated from DCM as purple solids. Both salts were studied in detail by 1D and 2D (COSY, DEPT, HSQC, and HMBC) NMR. Restricted rotation of the *N*-methylindole moiety is clearly deduced from <sup>1</sup>H NMR for both methylum salts by broadening the pair of protons at δ 8.82/7.43 and 8.62/6.85 ppm, respectively (Figure 5, Figure 6 and Supporting Information File 1). Assignments of the quaternary carbons including the formal carbocation centers were made by HMBC correlations.

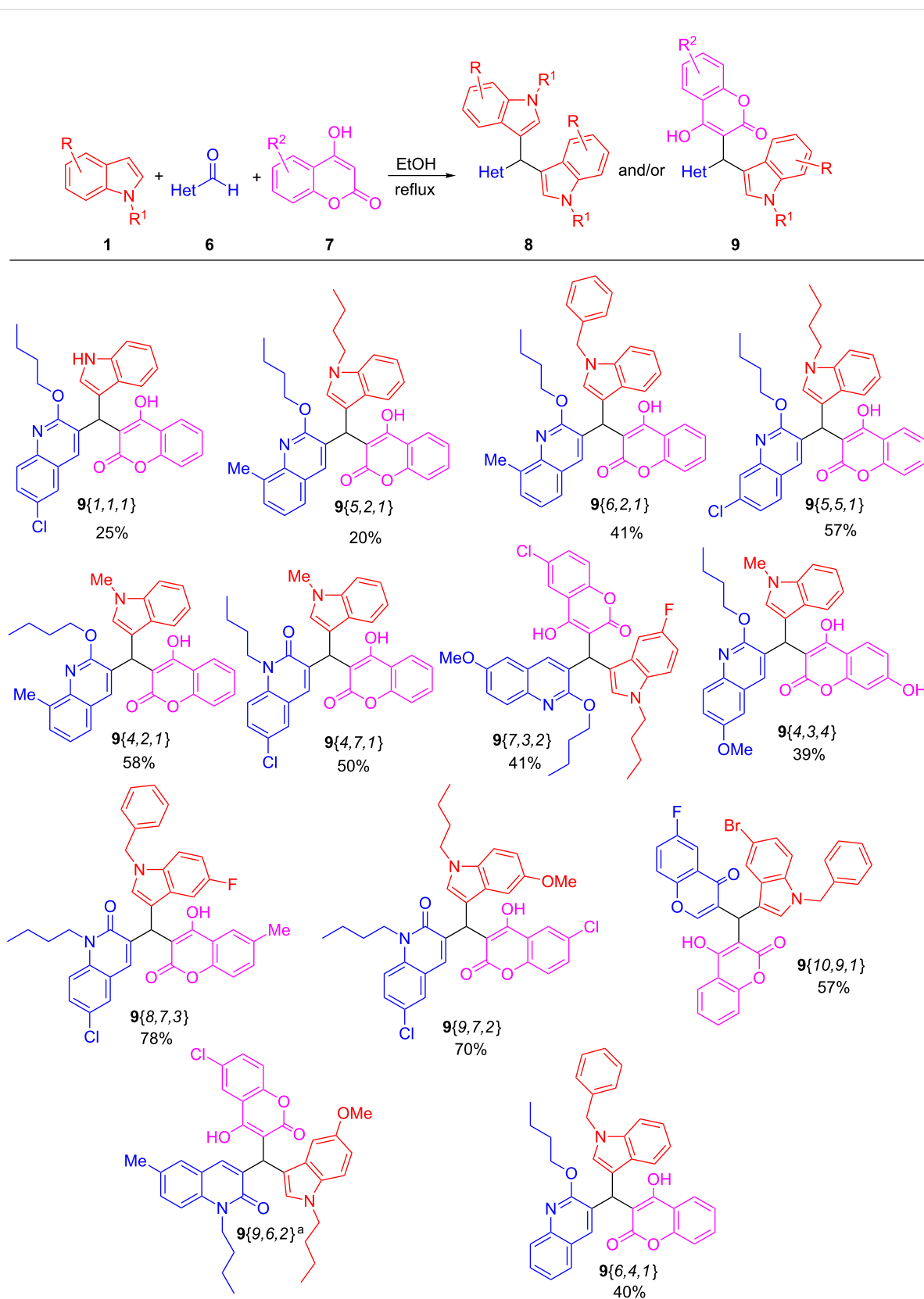
NMR data suggest that the positive charge is more effectively delocalized into the indole rings. The GIAO-NMR data show the same general trend, as evidenced by the <sup>13</sup>C Δδ chemical shifts, with largest charge locations at the conjugated carbon of the indole ring (Figure S2, Supporting Information File 1). The DFT-optimized structures of methylum-PF<sub>6</sub> salts **10**{4,4,8} and **10**{4,4,11} are shown in Figure 7 and Figure 8, where close cation–anion contacts are observed despite significant steric crowding. Steric congestion restricts the conjugation of the carbocationic center with the aromatic/heteroaromatic substituents, as evidenced by the bond length shortenings from only 0.052 Å to 0.111 Å observed upon hydride abstraction. The optimized geometries confirm the restricted rotation of the *N*-methylindole moiety deduced from experimental <sup>1</sup>H NMR for both methylum salts as described above (broadening of pair of protons at δ 8.82/7.43 and 8.62/6.85 ppm), as this moiety is anchored by the position of the PF<sub>6</sub><sup>−</sup> anion (Figure 7 and Figure 8). The distance between the formal carbocationic center and the closest fluorine atom was 3.084 Å in the methylum-PF<sub>6</sub> salt **10**{4,4,8}, and 3.275 Å in case of the **10**{4,4,11} salt. Moreover, C–H⋯F interactions were also observed, with H⋯F bond distances between 2.094 Å and 2.575 Å.

## Conclusion

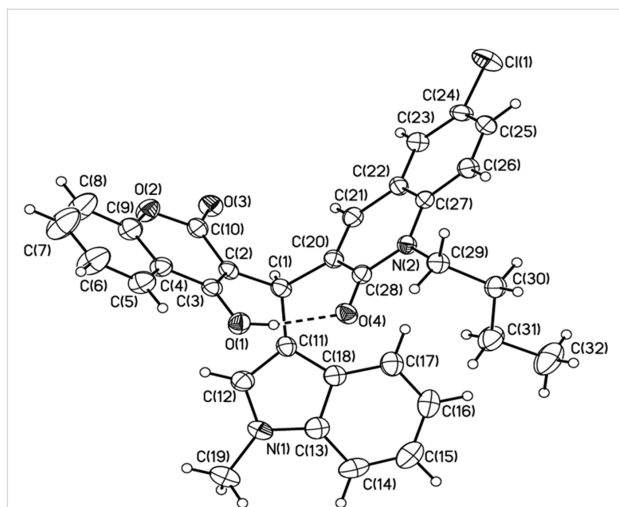
A facile one-pot method for the three-component synthesis of ternary heteroarylmethane-inspired hybrids is presented, by coupling quinoline aldehydes, quinolone aldehydes, chromene aldehydes, and fluorene aldehydes with substituted indoles and coumarins. The method enabled the synthesis of novel libraries



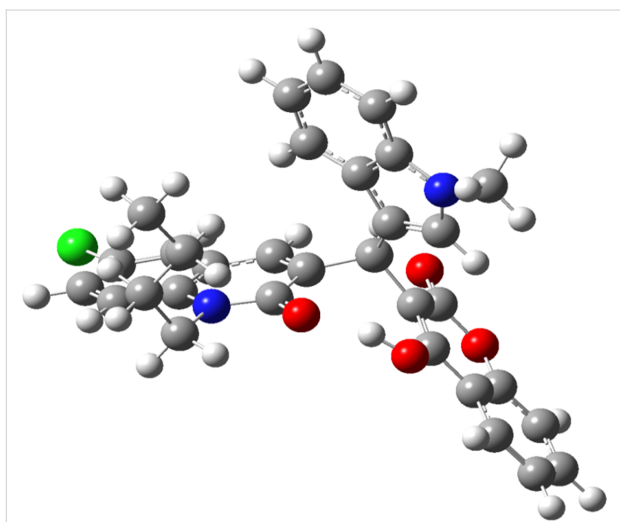
**Scheme 7:** Chemset of further aldehydes **6**{8–10} for elaboration in the MCR experiments.



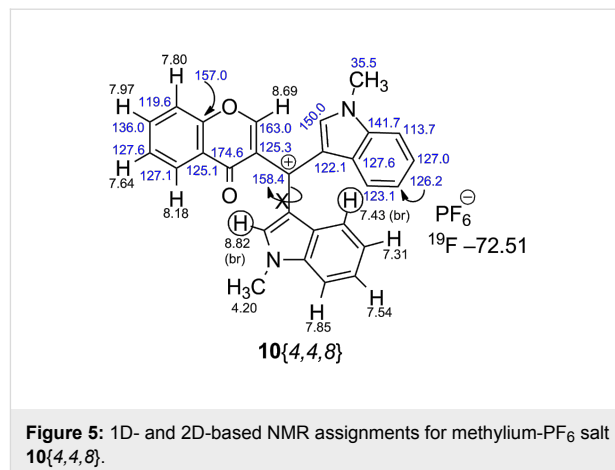
**Figure 2:** Three-component synthesis of tris(heteroaryl)methane triads **9**. <sup>a</sup>This product was obtained as an inseparable mixture along compound **8**{9,9,6} (see Supporting Information File 1).



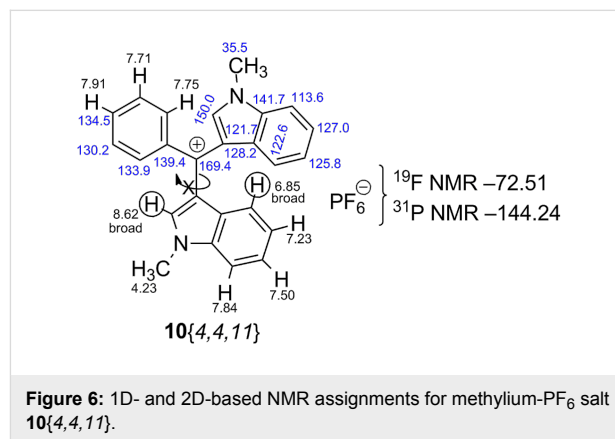
**Figure 3:** Thermal ellipsoid plot (40% probability level) of the tris(heteroaryl)methane triad **9**{4,7,1}.



**Figure 4:** DFT-optimized structure of **9**{4,7,1} triad.

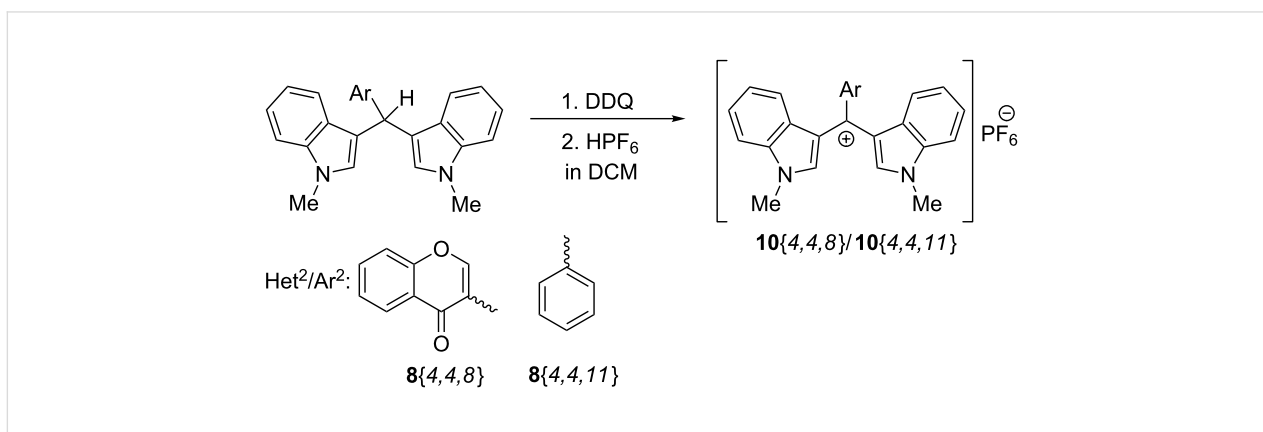


**Figure 5:** 1D- and 2D-based NMR assignments for methylum-PF<sub>6</sub> salt **10**{4,4,8}.



**Figure 6:** 1D- and 2D-based NMR assignments for methylum-PF<sub>6</sub> salt **10**{4,4,11}.

of giant (Ar<sup>1</sup>Ar<sup>1</sup>Ar<sup>2</sup>)CH and (Ar<sup>1</sup>Ar<sup>2</sup>Ar<sup>3</sup>)CH triads **8** and **9**, respectively, packed with up to three different pharmacophors in a single molecule. The ability to perform these reactions in ethanol and even in water, with no catalysts is noteworthy. Representative methylum salts generated by ionization with DDQ/HPF<sub>6</sub> exhibited <sup>1</sup>H NMR signal broadening reflecting restricted rotation of the *N*-methylindole moieties at room temperature.



**Scheme 8:** Synthesis of crowded (Het<sup>1</sup><sub>2</sub>Het<sup>2</sup>/Ar<sup>2</sup>)C<sup>+</sup>PF<sub>6</sub><sup>−</sup> salts **10**.

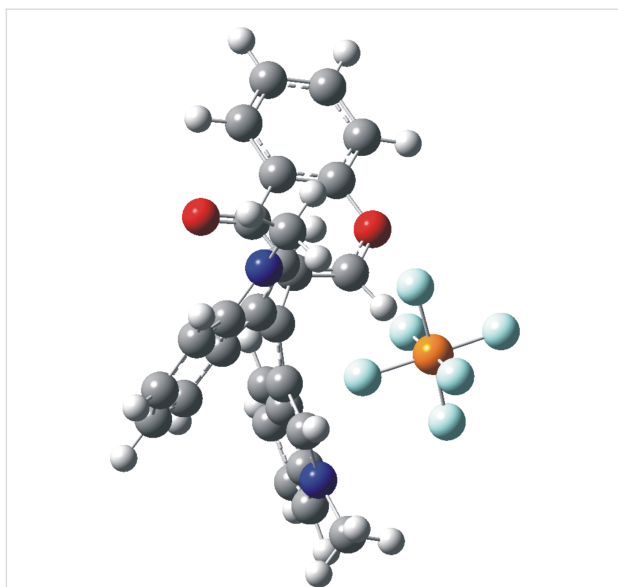


Figure 7: Optimized geometry of methylum-PF<sub>6</sub> salts 10{4,4,8}.

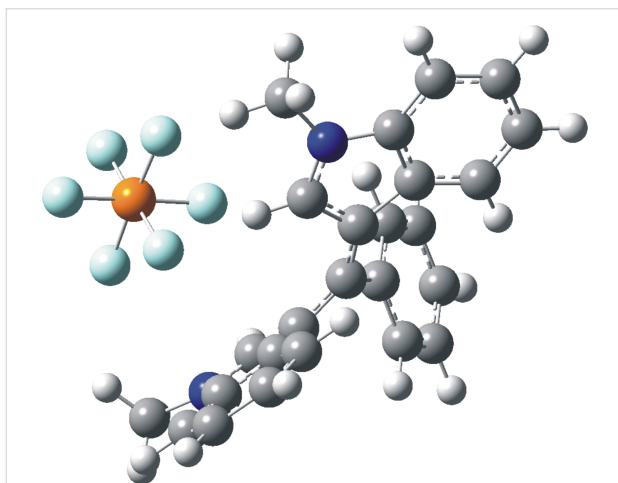


Figure 8: Optimized geometry of methylum-PF<sub>6</sub> salt 10{4,4,11}.

## Experimental

**General.** Melting points were measured using a Stuart SMP3 melting point apparatus and are uncorrected. IR spectra were recorded on a Shimadzu IRAffinity-1 spectrophotometer by ATR method. <sup>1</sup>H and <sup>13</sup>C NMR spectra were recorded on Bruker Avance 400 and Varian INOVA 500 MHz instruments using DMSO-*d*<sub>6</sub> and CDCl<sub>3</sub> as solvents with and without added TMS as internal standard. Mass spectra were run on a SHIMADZU-GCMS 2010-DI-2010 spectrometer (equipped with a direct inlet probe) operating at 70 eV. HRMS analyses were performed on a Finnigan Quantum ultra-AM in electrospray mode using methanol as solvent. Single-crystal X-ray data for compound 9{4,7,1} was collected at 200 K on a Bruker AXS diffractometer upgraded with an APEX II CCD detector. Crystallo-

graphic data for the structure has been deposited with the Cambridge Crystallographic Data Centre as supplementary publication no: CCDC 1864804. TLC analyses were performed on silica gel aluminum plates (Merck 60 F<sub>254</sub>) and spots visualized under UV light. The starting precursors and reagents for the synthesis of indoles 1{4–9} and quinoline-/quinolone aldehydes 6, and the required solvents were purchased from Sigma-Aldrich, Fluka and Merck (analytical grade reagent), and were used without further purification.

**Catalyzed general procedure for the direct synthesis of bisindoles 8.** A mixture of indole 1 (2.0 equiv), aldehyde 6 (1.0 equiv), Yb(OTf)<sub>3</sub> (5 mol %) and ACN (2 mL), was stirred at ambient temperature for 6 h until the starting materials 1 and 6 were no longer detected by TLC. The white precipitate formed was collected by filtration and washed with cold EtOH (2 × 0.5 mL). No further purification of product 8 was required. Alternatively, the more expensive Lewis acid Sc(OTf)<sub>3</sub> was used instead of Yb(OTf)<sub>3</sub> with similar behavior and results, although, reactions just took about 3 h. In the case of I<sub>2</sub>, although, the reaction worked quite well, the isolation of products 8 required filtering the colored solid formed and treatment of the re-dissolved solid in ethyl acetate with sodium thiosulfate to destroy the excess iodine. Finally, purification of the crude reaction mixtures by column chromatography was required in all cases.

**Uncatalyzed general procedure for the synthesis of products 9.** An equimolar mixture of the appropriate indole 1 (1.0 equiv), aldehyde 6 (1.0 equiv), and 4-hydroxycoumarin 7 (1.0 equiv) was dissolved in ethanol (2 mL). The solution was heated to reflux for 3 h until the starting materials 1 and 6 were no longer detected by TLC. After the solvent was removed under reduced pressure, the crude reaction mixture was purified by column chromatography on silica gel, using hexane/EtOAc (7:3) as eluent. The desired products 9 along with the side-products 8 were isolated and quantified.

**General procedure for the synthesis of carbocation salts 10{4,4,8} and 10{4,4,11}.** DDQ (2 equiv) was added to a solution of 3,3'-(arylmethylene)bis(1-methyl-1*H*-indoles) 8{4,4,8} or 8{4,4,11} (50 mg, 1 equiv) in CH<sub>2</sub>Cl<sub>2</sub> (8 mL) at room temperature. After the solution was stirred at the same temperature for 30 min, 60% HPF<sub>6</sub> (1 mL) and water (10 mL) were added to the mixture. The resulting suspension was filtered with suction. The organic layer was washed with water, dried over MgSO<sub>4</sub>, and concentrated under reduced pressure. Finally, the crystals were obtained after simple trituration with Et<sub>2</sub>O.

**Computational methods.** Density functional theory (DFT) calculations were carried out with the Gaussian 09 program

suite [66]. Geometries were fully optimized at the B3LYP [67–69]/6-311+G(d,p) level. Stationary points were characterized as minima by harmonic vibrational frequency calculations (no imaginary frequencies). NMR chemical shifts were computed by the GIAO (gauge independent atomic orbitals) [70,71] method at the B3LYP/6-311+G(d,p) level. The  $^1\text{H}$  and  $^{13}\text{C}$  NMR chemical shifts were referenced to TMS. GIAO magnetic shielding tensors were 31.88 for  $^1\text{H}$ , 182.5 for  $^{13}\text{C}$ , values related to the GIAO isotropic magnetic susceptibility.

**X-ray crystallography.** Colorless crystals were isolated for **9**{4,7,1} from acetonitrile and used for the following X-ray diffraction studies. A crystal was mounted onto a fiber from Fluorolube<sup>TM</sup> and was placed under a liquid  $\text{N}_2$  cooled stream, on a Bruker AXS diffractometer updated with an APEX II CCD detector. The radiation used was graphite monochromatized Mo  $K\alpha$  radiation ( $\lambda = 0.7107 \text{ \AA}$ ). Lattice determination, data collection, structure refinement, scaling, and data reduction were carried out using the APEX2 Version 2014.11 software package [72,73]. The data were corrected for absorption using the SCALE program within the APEX2 software suite [72,73]. The structure was solved using SHELXT [74]. This procedure yielded a number of the C, N and O atoms. Subsequent Fourier synthesis yielded the remaining atom positions. The hydrogen atoms are fixed in positions of ideal geometry (riding model) and refined within the X-SHELL software package [75]. The final refinement of the compound included anisotropic thermal parameters on all non-hydrogen atoms was performed using OLEX2-1.2 [76]. The crystal data for compound **9**{4,7,1} is given in Table S1, and a packing diagram is shown in Figure S1 [77] (Supporting Information File 1). Crystallographic data for the structure has been deposited with the Cambridge Crystallographic Data Centre as supplementary publication no: CCDC 1864804. Copies of the data can be obtained on application to the CCDC, 12 Union Road, Cambridge CB2 1EZ, UK (fax, +44-(0)1223-336033; or email, [deposit@ccdc.cam.ac.uk](mailto:deposit@ccdc.cam.ac.uk)).

## Supporting Information

### Supporting Information File 1

Spectroscopic data for compounds **8** and **9**, copies of NMR spectra and additional Table and Figures.

[<https://www.beilstein-journals.org/bjoc/content/supplementary/1860-5397-15-60-S1.pdf>]

### Supporting Information File 2

CIF report for **9**{4,7,1}.

[<https://www.beilstein-journals.org/bjoc/content/supplementary/1860-5397-15-60-S2.pdf>]

## Acknowledgements

Authors thank COLCIENCIAS and Universidad del Valle for financial support—Project Numbers 110665842661 and CI-71111. L.G. specially thanks COLCIENCIAS for her “Joven Investigador” fellowship award. K.K.L. thanks the University of North Florida for the outstanding faculty scholarship and presidential professorship awards, as well as faculty scholarship and UNF Foundation Board grants. G.L.B. acknowledges funding from CONICET and Secyt-UNC.

## ORCID® iDs

Jairo Quiroga - <https://orcid.org/0000-0002-9451-3063>

Kenneth K. Laali - <https://orcid.org/0000-0002-0294-844X>

Gabriela L. Borosky - <https://orcid.org/0000-0001-7660-962X>

## References

- Dömling, A. *Chem. Rev.* **2006**, *106*, 17–89. doi:10.1021/cr0505728
- Shiri, M. *Chem. Rev.* **2012**, *112*, 3508–3549. doi:10.1021/cr2003954
- da Silveira Pinto, L. S.; Couri, M. R. C.; de Souza, M. V. N. *Curr. Org. Synth.* **2018**, *15*, 21–37. doi:10.2174/1570179414666170614124053
- Mohammadi Ziarani, G.; Moradi, R.; Ahmadi, T.; Lashgari, N. *RSC Adv.* **2018**, *8*, 12069–12103. doi:10.1039/c7ra13321a
- Vroemans, R.; Verhaegen, Y.; Dieu, M. T. T.; Dehaen, W. *Beilstein J. Org. Chem.* **2018**, *14*, 2689–2697. doi:10.3762/bjoc.14.246
- Shanab, K.; Neudorfer, C.; Schirmer, E.; Spreitzer, H. *Curr. Org. Chem.* **2013**, *17*, 1179–1187. doi:10.2174/1385272811317110005
- Gu, Y. *Green Chem.* **2012**, *14*, 2091–2128. doi:10.1039/c2gc35635j
- Nair, V.; Thomas, S.; Mathew, S. C.; Abhilash, K. G. *Tetrahedron* **2006**, *62*, 6731–6747. doi:10.1016/j.tet.2006.04.081
- Podder, S.; Choudhury, J.; Roy, U. K.; Roy, S. J. *Org. Chem.* **2007**, *72*, 3100–3103. doi:10.1021/jo062633n
- Gomes, R. F. A.; Coelho, J. A. S.; Frade, R. F. M.; Trindade, A. F.; Afonso, C. A. M. *J. Org. Chem.* **2015**, *80*, 10404–10411. doi:10.1021/acs.joc.5b01875
- Khaksar, S.; Vahdat, S. M.; Gholizadeh, M.; Talesh, S. M. *J. Fluorine Chem.* **2012**, *136*, 8–11. doi:10.1016/j.jfluchem.2012.01.002
- Kumar Das, S.; Shagufta; Panda, G. *Tetrahedron Lett.* **2005**, *46*, 3097–3102. doi:10.1016/j.tetlet.2005.03.001
- Bushby, S. R. M. Toxicity in Chemotherapy. In *Experimental Chemotherapy*; Schnitzer, R. J.; Hawking, F., Eds.; Academic Press: New York, NY, 1963; Vol. 1, pp 25–53. doi:10.1016/c2013-0-12425-7
- Yamato, M.; Hashigaki, K.; Yasumoto, Y.; Sakai, J.; Luduena, R. F.; Banerjee, A.; Tsukagoshi, S.; Tashiro, T.; Tsuruo, T. *J. Med. Chem.* **1987**, *30*, 1897–1900. doi:10.1021/jm00393a035
- Wulff, H.; Miller, M. J.; Hänsel, W.; Grissmer, S.; Cahalan, M. D.; Chandy, K. G. *Proc. Natl. Acad. Sci. U. S. A.* **2000**, *97*, 8151–8156. doi:10.1073/pnas.97.14.8151
- Mibu, N.; Yokomizo, K.; Uyeda, M.; Sumoto, K. *Chem. Pharm. Bull.* **2003**, *51*, 1325–1327. doi:10.1248/cpb.51.1325
- Rys, P.; Zollinger, H. *Fundamentals of the Chemistry and Application of Dyes*; Wiley-Interscience: New York, NY, 1972.
- Aldag, R. Photochromism based on dissociation processes. In *Photochromism: Molecules and Systems*; Dürr, H.; Bouas-Laurent, H., Eds.; Elsevier: London, 1990.
- Shchepinov, M. S.; Korshun, V. A. *Chem. Soc. Rev.* **2003**, *32*, 170–180. doi:10.1039/b008900i

20. Baker, L. A.; Sun, L.; Crooks, R. M. *Bull. Korean Chem. Soc.* **2002**, *23*, 647–654. doi:10.5012/bkcs.2002.23.5.647
21. Sanguinet, L.; Twieg, R. J.; Wiggers, G.; Mao, G.; Singer, K. D.; Petschek, R. G. *Tetrahedron Lett.* **2005**, *46*, 5121–5125. doi:10.1016/j.tetlet.2005.05.138
22. Yu, L.; Li, S.-S.; Li, W.; Yu, S.; Liu, Q.; Xiao, J. *J. Org. Chem.* **2018**, *83*, 15277–15283. doi:10.1021/acs.joc.8b02549
23. Oikawa, Y.; Hirasawa, H.; Yonemitsu, O. *Tetrahedron Lett.* **1978**, *19*, 1759–1762. doi:10.1016/0040-4039(78)80037-9
24. Lü, C.-W.; Wang, J.-J.; Liu, Y.-H.; Shan, W.-J.; Sun, Q.; Shi, L. *Res. Chem. Intermed.* **2017**, *43*, 943–949. doi:10.1007/s11164-016-2675-8
25. Renzetti, A.; Boffa, E.; Colazzo, M.; Gérard, S.; Sapi, J.; Chan, T.-H.; Nakazawa, H.; Villani, C.; Fontana, A. *RSC Adv.* **2014**, *4*, 47992–47999. doi:10.1039/c4ra08853k
26. Gérard, S.; Renzetti, A.; Lefevre, B.; Fontana, A.; de Maria, P.; Sapi, J. *Tetrahedron* **2010**, *66*, 3065–3069. doi:10.1016/j.tet.2010.02.025
27. Viegas-Junior, C.; Danuello, A.; da Silva-Bolzani, V.; Barreiro, E. J.; Fraga, C. A. M. *Curr. Med. Chem.* **2007**, *14*, 1829–1852. doi:10.2174/092986707781058805
28. Zhang, S.; Saathoff, J. M.; He, L. Molecular Hybridization: An Emerging Tool for the Design of Novel Therapeutics for Alzheimer's Disease. In *Design of Hybrid Molecules for Drug Development*; Decker, M., Ed.; Elsevier: Amsterdam, 2017; pp 219–237. doi:10.1016/b978-0-08-101011-2.00008-8
29. Rad-Moghadam, K.; Mohseni, M. *Monatsh. Chem.* **2004**, *135*, 817–821. doi:10.1007/s00706-003-0138-6
30. Alizadeh, A.; Ghanbaripour, R.; Zhu, L.-G. *Tetrahedron* **2014**, *70*, 2048–2053. doi:10.1016/j.tet.2014.01.038
31. El-Mekabaty, A.; Mesbah, A.; Fadda, A. A. *J. Heterocycl. Chem.* **2017**, *54*, 916–922. doi:10.1002/jhet.2654
32. Joule, J. A. In *Houben-Weyl Methods of Molecular Transformations*; Thomas, E. J., Ed.; Science of Synthesis; Georg Thieme Verlag: Stuttgart, Germany, 2000; p 10.
33. Mugnaini, C.; Nocerino, S.; Pedani, V.; Pasquini, S.; Tafi, A.; De Chiaro, M.; Bellucci, L.; Valoti, M.; Guida, F.; Luongo, L.; Dragoni, S.; Ligresti, A.; Rosenberg, A.; Bolognini, D.; Cascio, M. G.; Pertwee, R. G.; Moaddel, R.; Maione, S.; Di Marzo, V.; Corelli, F. *ChemMedChem* **2012**, *7*, 920–934. doi:10.1002/cmdc.201100573
34. Chung, H. J.; Kamli, M. R.; Lee, H. J.; Ha, J. D.; Cho, S. Y.; Lee, J.; Kong, J. Y.; Han, S.-Y. *Biochem. Biophys. Res. Commun.* **2014**, *445*, 561–565. doi:10.1016/j.bbrc.2014.02.029
35. Rezayan, A. H.; Hariri, S.; Azerang, P.; Ghavami, G.; Portugal, I.; Sardari, S. *Iran. J. Pharm. Res.* **2017**, *16*, 745–755.
36. Hranjec, M.; Lučić, B.; Ratkaj, I.; Kraljević Pavelić, S.; Piantanida, I.; Pavelić, K.; Karminski-Zamola, G. *Eur. J. Med. Chem.* **2011**, *46*, 2748–2758. doi:10.1016/j.ejmech.2011.03.062
37. Desyatkin, V. G.; Beletskaya, I. P. *Synthesis* **2017**, *49*, 4327–4334. doi:10.1055/s-0036-1589024
38. Karthik, G.; Rajasekaran, T.; Sridhar, B.; Subba Reddy, B. V. *Tetrahedron* **2014**, *70*, 8148–8154. doi:10.1016/j.tet.2014.07.093
39. Jadhav, S. D.; Bakshi, D.; Singh, A. *J. Org. Chem.* **2015**, *80*, 10187–10196. doi:10.1021/acs.joc.5b01736
40. Shelke, G. M.; Kumar, A. *Synthesis* **2017**, *49*, 4321–4326. doi:10.1055/s-0036-1588181
41. Deb, M. L.; Deka, B.; Saikia, P. J.; Baruah, P. K. *Tetrahedron Lett.* **2017**, *58*, 1999–2003. doi:10.1016/j.tetlet.2017.04.032
42. Teguh, S. C.; Klonis, N.; Duffy, S.; Lucantoni, L.; Avery, V. M.; Hutton, C. A.; Baell, J. B.; Tilley, L. *J. Med. Chem.* **2013**, *56*, 6200–6215. doi:10.1021/jm400656s
43. Lin, W.; Yuan, L.; Cao, Z.; Feng, J.; Feng, Y. *Dyes Pigm.* **2009**, *83*, 14–20. doi:10.1016/j.dyepig.2009.03.006
44. Khan, M. N.; Pal, S.; Karamthulla, S.; Choudhury, L. H. *New J. Chem.* **2014**, *38*, 4722–4729. doi:10.1039/c4nj00630e
45. Oelerich, J.; Roelfes, G. *Org. Biomol. Chem.* **2015**, *13*, 2793–2799. doi:10.1039/c4ob02487g
46. Shao, Z.; Xu, L.; Wang, L.; Wei, H.; Xiao, J. *Org. Biomol. Chem.* **2014**, *12*, 2185–2188. doi:10.1039/c3ob42582g
47. Jennings, J. J.; Bhatt, C. P.; Franz, A. K. *J. Org. Chem.* **2016**, *81*, 6211–6222. doi:10.1021/acs.joc.6b00541
48. Prabhakar, M.; Reddy, G. N.; Srinu, G.; Manjulatha, K.; Prasad, J. V.; Kumar, S. P.; Srinivas, O.; Iqbal, J.; Kumar, K. A. *Synlett* **2010**, 947–951. doi:10.1055/s-0029-1219532
49. Shiri, M.; Zolfigol, M. A.; Kruger, H. G.; Tanbakouchian, Z. *Chem. Rev.* **2010**, *110*, 2250–2293. doi:10.1021/cr900195a
50. Kottawar, S. S.; Siddiqui, S. A.; Pandalwar, S. S.; Jadhav, W. N.; Bhusare, S. R. *Res. Chem. Intermed.* **2014**, *40*, 2929–2934. doi:10.1007/s11164-013-1139-7
51. Shelke, G. M.; Rao, V. K.; Tiwari, R. K.; Chhikara, B. S.; Parang, K.; Kumar, A. *RSC Adv.* **2013**, *3*, 22346–22352. doi:10.1039/c3ra44693j
52. Appendino, G.; Cicione, L.; Minassi, A. *Tetrahedron Lett.* **2009**, *50*, 5559–5561. doi:10.1016/j.tetlet.2009.05.033
53. Mousavizadeh, F.; Hekmatshoar, R.; Beheshtitha, S. Y. S.; Rahnamafar, R. *Synth. Commun.* **2014**, *44*, 1483–1491. doi:10.1080/00397911.2013.862723
54. Laali, K. K.; Insuasty, D.; Abonia, R.; Insuasty, B.; Bunge, S. D. *Tetrahedron Lett.* **2014**, *55*, 4395–4399. doi:10.1016/j.tetlet.2014.05.094
55. Ramírez-Prada, J.; Robledo, S. M.; Vélez, I. D.; del Pilar Crespo, M.; Quiroga, J.; Abonia, R.; Montoya, A.; Svetaz, L.; Zacchino, S.; Insuasty, B. *Eur. J. Med. Chem.* **2017**, *131*, 237–254. doi:10.1016/j.ejmech.2017.03.016
56. Abonia, R.; Insuasty, D.; Castillo, J.; Insuasty, B.; Quiroga, J.; Noguera, M.; Cobo, J. *Eur. J. Med. Chem.* **2012**, *57*, 29–40. doi:10.1016/j.ejmech.2012.08.039
57. Insuasty, D.; Abonia, R.; Insuasty, B.; Quiroga, J.; Laali, K. K.; Noguera, M.; Cobo, J. *ACS Comb. Sci.* **2017**, *19*, 555–563. doi:10.1021/acscmb.7b00091
58. Kong, A.; Han, X.; Lu, X. *Org. Lett.* **2006**, *8*, 1339–1342. doi:10.1021/ol060039u
59. Meth-Cohn, O.; Narine, B. *Tetrahedron Lett.* **1978**, *19*, 2045–2048. doi:10.1016/s0040-4039(01)94745-8
60. Meth-Cohn, O.; Narine, B.; Tarnowski, B. *J. Chem. Soc., Perkin Trans. 1* **1981**, 1520–1530. doi:10.1039/p19810001520
61. Oda, M.; Fukuta, A.; Kajioaka, T.; Uchiyama, T.; Kainuma, H.; Miyatake, R.; Kuroda, S. *Tetrahedron* **2000**, *56*, 9917–9925. doi:10.1016/s0040-4020(00)00964-9  
See for an example.
62. Ito, S.; Akimoto, K.; Morita, N. In *Recent Developments in Carbocation and Onium Ion Chemistry*; Laali, K. K., Ed.; ACS Symposium Series 965; ACS: Washington, DC, 2007; pp 160–183.  
See for DDQ/HPF<sub>6</sub> previously employed for generation of tri(1-azulenyl)methyl cation salts.
63. Ito, S.; Morita, N.; Asao, T. *Bull. Chem. Soc. Jpn.* **1995**, *68*, 1409–1436. doi:10.1246/bcsj.68.1409
64. Pfeuffer, L.; Mueller, J.; Pindur, U. *Chimia* **1985**, *39*, 141–142.  
See for 3-indolylmethylethoxycarbenium BF<sub>4</sub> salt.
65. Pindur, U.; Mueller, J. *Chem.-Ztg.* **1986**, *110*, 333–335.  
See for a UV-vis study of diindolylmethylum.

66. *Gaussian 09*, Revision E.01; Gaussian, Inc.: Wallingford, CT, 2009.
67. Becke, A. D. *J. Chem. Phys.* **1993**, *98*, 5648–5652.  
doi:10.1063/1.464913
68. Lee, C.; Yang, W.; Parr, R. G. *Phys. Rev. B* **1988**, *37*, 785–789.  
doi:10.1103/physrevb.37.785
69. Miehlich, B.; Savin, A.; Stoll, H.; Preuss, H. *Chem. Phys. Lett.* **1989**, *157*, 200–206. doi:10.1016/0009-2614(89)87234-3
70. Wolinski, K.; Hinton, J. F.; Pulay, P. *J. Am. Chem. Soc.* **1990**, *112*, 8251–8260. doi:10.1021/ja00179a005
71. Ditchfield, R. *Mol. Phys.* **1974**, *27*, 789–807.  
doi:10.1080/00268977400100711
72. *APEX II*; Bruker AXS, Inc., Analytical X-ray Systems: 5465 East Cheryl Parkway, Madison WI 53711–5373, USA, 2005.
73. *SAINT*, Version 6.45A; Bruker AXS, Inc., Analytical X-ray Systems: 5465 East Cheryl Parkway, Madison WI 53711–5373, USA, 2003.
74. Sheldrick, G. M. *Acta Crystallogr., Sect. A: Found. Adv.* **2015**, *71*, 3–8.  
doi:10.1107/s2053273314026370
75. *SHELXTL*, V6.12; Bruker AXS, Inc., Analytical X-ray Systems: East Cheryl Parkway, Madison WI 53711–5373, USA, 2002.
76. Dolomanov, O. V.; Bourhis, L. J.; Gildea, R. J.; Howard, J. A. K.; Puschmann, H. *J. Appl. Crystallogr.* **2009**, *42*, 339–341.  
doi:10.1107/s0021889808042726
77. *DIAMOND*, Bonn, Germany; Crystal Impact GbR, 1999.

## License and Terms

This is an Open Access article under the terms of the Creative Commons Attribution License (<http://creativecommons.org/licenses/by/4.0>). Please note that the reuse, redistribution and reproduction in particular requires that the authors and source are credited.

The license is subject to the *Beilstein Journal of Organic Chemistry* terms and conditions: (<https://www.beilstein-journals.org/bjoc>)

The definitive version of this article is the electronic one which can be found at:  
doi:10.3762/bjoc.15.60



# The LANCA three-component reaction to highly substituted $\beta$ -ketoenamides – versatile intermediates for the synthesis of functionalized pyridine, pyrimidine, oxazole and quinoxaline derivatives

Tilman Lechel<sup>1</sup>, Roopender Kumar<sup>1,2</sup>, Mrinal K. Bera<sup>1,3</sup>, Reinhold Zimmer<sup>1</sup> and Hans-Ulrich Reissig<sup>\*1</sup>

## Review

Open Access

### Address:

<sup>1</sup>Institut für Chemie und Biochemie, Freie Universität Berlin, Takustr. 3, D-14195 Berlin, Germany, <sup>2</sup>Department of Chemistry, University of Cambridge, Lensfield Road, CB2 1EW Cambridge, UK, and <sup>3</sup>Department of Chemistry, Indian Institute of Engineering Science and Technology, Shibpur, PO-Botanic Garden, Howrah-711 103 (WB), India

### Email:

Hans-Ulrich Reissig<sup>\*</sup> - hreissig@chemie.fu-berlin.de

\* Corresponding author

### Keywords:

allenes; condensations; multicomponent reactions; oxazoles; pyrimidines; quinoxalines

*Beilstein J. Org. Chem.* **2019**, *15*, 655–678.

doi:10.3762/bjoc.15.61

Received: 20 December 2018

Accepted: 20 February 2019

Published: 13 March 2019

This article is part of the thematic issue "Multicomponent reactions III". Dedicated to Professor Armin de Meijere on the occasion of his 80th birthday.

Guest Editor: T. J. J. Müller

© 2019 Lechel et al.; licensee Beilstein-Institut.

License and terms: see end of document.

## Abstract

The LANCA three-component reaction of lithiated alkoxyallenes **LA**, nitriles **N** and carboxylic acids **CA** leads to  $\beta$ -ketoenamides **KE** in good to excellent yields. The scope of this reaction is very broad and almost all types of nitriles and carboxylic acids have successfully been used. The alkoxy group introduced via the allene component is also variable and hence the subsequent transformation of this substituent into a hydroxy group can be performed under different conditions. Enantiopure nitriles or carboxylic acids can also be employed leading to chiral **KE** with high enantiopurity and dinitriles or dicarboxylic acids also lead to the expected bis- $\beta$ -ketoenamides.  $\beta$ -Ketoenamides incorporate a unique combination of functional groups and hence a manifold of subsequent reactions to highly substituted heterocyclic compounds is possible. An intramolecular aldol-type condensation reaction efficiently furnishes pyridin-4-ols **PY** that can be further modified by palladium-catalyzed reactions, e.g., to specifically substituted furopyridine derivatives. Condensations of  $\beta$ -ketoenamides with ammonium salts or with hydroxylamine hydrochloride afford pyrimidines **PM** or pyrimidine *N*-oxides **PO** with a highly flexible substitution pattern in good yields. The functional groups of these heterocycles also allow a variety of subsequent reactions to various pyrimidine derivatives. On the other hand, acid-labile alkoxy substituents such as a 2-(trimethylsilyl)ethoxy group are required for the conversion of  $\beta$ -ketoenamides into 5-acetyl-substituted oxazoles **OX**, again compounds with high potential for subsequent functional group transformations. For acid labile  $\beta$ -ketoenamides bearing bulky substituents the acid treatment leads to acylamido-substituted 1,2-diketones **DK** that could be converted into

quinoxalines **QU**. All classes of heterocycles accessed through the key  $\beta$ -ketoenamides show a unique substitution pattern – not easily accomplishable by alternative methods – and therefore many subsequent reactions are possible.

## Introduction

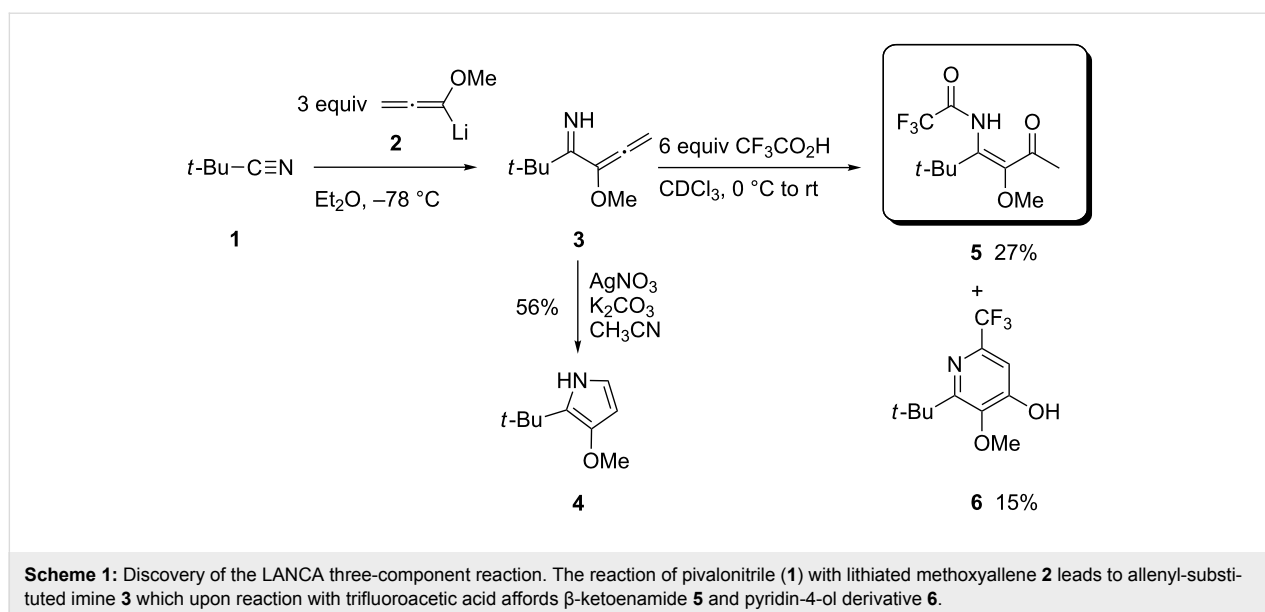
Multicomponent reactions are known to create unique product skeletons in an atom economic, efficient and time saving fashion. In many cases, compounds bearing functional groups of relatively high energy level with the potential of multiple reactivity are employed, for instance nitriles, isonitriles or alkynes [1-9]. Not surprisingly, simple or functionalized allenes have also been used in multicomponent processes and – dependent on the substitution pattern of the allene – a remarkable variety of reactions and product types are known using the three-carbon backbone of these reactive compounds [10]. During the exploration of alkoxyallene chemistry [11-20] we accidentally discovered a new three-component reaction leading to  $\beta$ -ketoenamides that are uniquely functionalized alkenes and suitable for a variety of subsequent reactions, in particular in heterocyclic synthesis.

This LANCA three-component reaction (**LA** = lithiated alkoxyallene, **N** = nitrile, **CA** = carboxylic acid) was observed for the first time by Oliver Flögel, who treated pivalonitrile (**1**) with lithiated methoxyallene **2** and isolated the expected primary addition product **3** [21]. This intermediate was subjected to different cyclization conditions (Scheme 1) and the desired pyrrole derivative **4** was produced under specific conditions employing silver nitrate as catalyst. However, the treatment of **3** with an excess of trifluoroacetic acid led to a mixture of  $\beta$ -ketoenamide **5** and pyridin-4-ol derivative **6**. Thus, the carboxylic

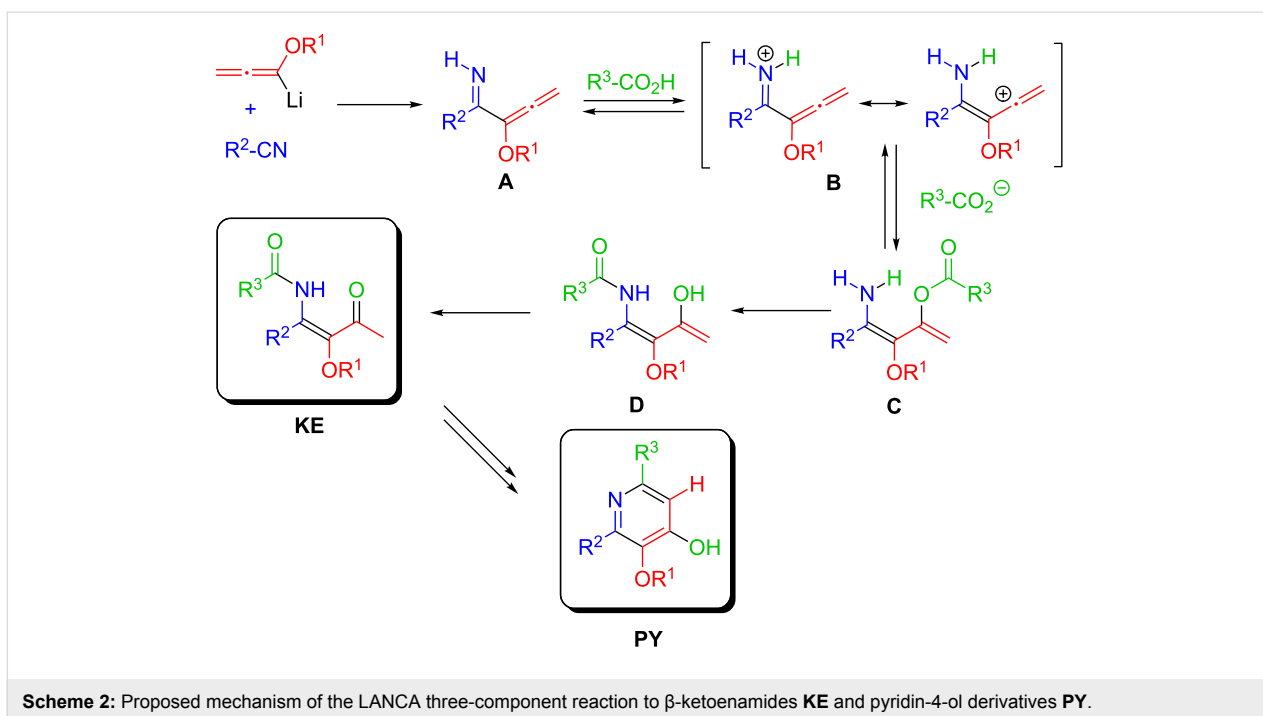
acid did not act as a catalyst in this reaction as expected, it was incorporated into the products!

The unique mechanism leading to the  $\beta$ -ketoenamide and the pyridin-4-ol has been discussed earlier [21-23], but the essentials of the involved cascade reactions have to be presented again in order to understand the formation of the crucial  $\beta$ -ketoenamide intermediates (Scheme 2). The protonation of the primarily formed allenylimine **A** by the added carboxylic acid at the nitrogen gives an allenyl iminium/aminobutadienyl cation intermediate **B** that accepts the present carboxylate at the electrophilic carbon to provide an acyloxy-substituted aminobutadiene derivative **C**. The acyl group is subsequently transferred to the close amino group giving **D** thus accomplishing the final connectivity of the three components. Enol/carbonyl tautomerization gives the isolated  $\beta$ -ketoenamide **KE** with *E*-configuration being the result of the intramolecular acyl transfer. Even after storage of  $\beta$ -ketoenamides there is no evidence that an isomerization to the corresponding *Z*-isomers occurs.

It should be noted here that the protonation to the allenyl iminium species **B** implies an “umpolung of reactivity” of the alkoxyallene subunit converting the central allene carbon to an electrophilic center whereas this carbon is a nucleophilic center in the neutral compound. The obtained  $\beta$ -ketoenamides are alkenes with a remarkable assembly of functional groups: they



**Scheme 1:** Discovery of the LANCA three-component reaction. The reaction of pivalonitrile (**1**) with lithiated methoxyallene **2** leads to allenyl-substituted imine **3** which upon reaction with trifluoroacetic acid affords  $\beta$ -ketoenamide **5** and pyridin-4-ol derivative **6**.

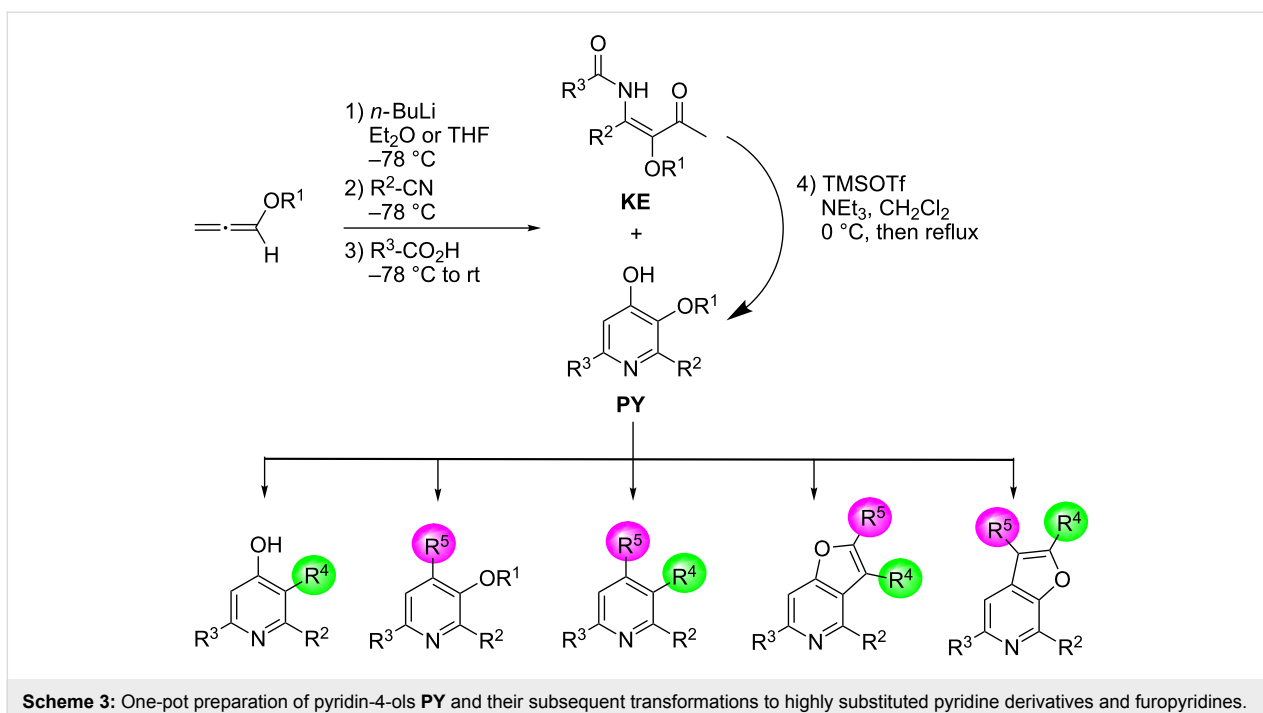


**Scheme 2:** Proposed mechanism of the LANCA three-component reaction to  $\beta$ -ketoenamides **KE** and pyridin-4-ol derivatives **PY**.

are enamides, enol ethers and  $\alpha,\beta$ -unsaturated carbonyl compounds at the same time. In addition, their methyl ketone subunit is required for some of the subsequent transformations, e.g., the synthesis of pyridin-4-ols **PY**.

The first reaction shown in Scheme 1 gave a mixture of  $\beta$ -ketoenamide **5** and its subsequent cyclization product pyridin-4-ol **6**

in low yields. This new route to highly substituted pyridin-4-ol derivatives could be streamlined as a one-pot procedure and after completion of the condensation reaction with trimethylsilyl trifluoromethanesulfonate (TMSOTf) and a tertiary amine as base a broad range of pyridine derivatives was accessible (Scheme 3). According to its discoverer, we named this reaction Flögel pyridine synthesis [21]. The reaction is very flex-



**Scheme 3:** One-pot preparation of pyridin-4-ols **PY** and their subsequent transformations to highly substituted pyridine derivatives and furopyridines.

ible with respect to the employed alkoxyallenes, nitriles and carboxylic acids and due to the two differently protected oxygen functions of the pyridin-4-ols these intermediates could be further substituted, e.g., through palladium-catalyzed reactions, to give highly substituted pyridine derivatives in a great variety. The scope and limitations of this approach as well as many subsequent reactions to a broad range of pyridine or furopyridine derivatives has recently been summarized in a comprehensive review [23]. It should be mentioned here, that alkoxyallenes are no exotic compounds but easily available in two steps from simple starting materials [24,25]. They can smoothly be prepared in multigram scale and recently a flow chemistry approach on the use of lithiated methoxyallene was published [26].

For the case, that substituents  $R^3$  are strongly electron withdrawing the relatively electrophilic amido carbonyl group of the  $\beta$ -ketoenamides partially undergoes a subsequent intramolecular aldol-type condensation reaction to furnish the pyridin-4-ols. Therefore, trifluoroacetic acid or related fluorinated carboxylic acids [22] lead to mixtures of the two products as shown in Scheme 1. For other carboxylic acids the multistep reaction of the three components stops at the stage of the  $\beta$ -ketoenamides that were usually isolated in good yields. These intermediates also provide pyridin-4-ols under slightly more rigorous condensation conditions, but they can also be used in alternative synthetic operations providing other compound classes, in particular heterocyclic compounds. The synthesis of pyrimidines **PM**, pyrimidine *N*-oxides **PO**, oxazoles **OX**, 1,2-diketones **DK** and quinoxalines **QU** starting from  $\beta$ -ketoenamides **KE** is the topic of the present review.

## Review

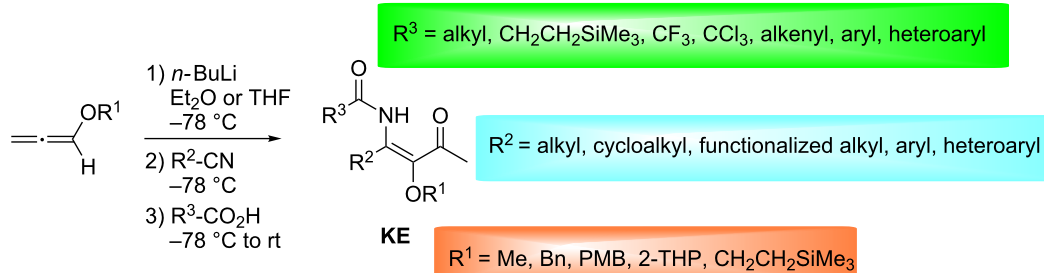
### Scope of the LANCA three-component synthesis of $\beta$ -ketoenamides

The scope of the LANCA three-component synthesis of  $\beta$ -ketoenamides **KE** through the reaction of alkoxyallenes, nitriles and carboxylic acids is very broad and only a few clear limitations were found (Scheme 4). With lithiated methoxyallene

( $R^1 = \text{Me}$ ) – the standard alkoxyallene generally used to study new reactions – many conceivable combinations of nitriles as second and carboxylic acids as third component were examined.

In Table 1 the resulting products **KE1–35** are collected, showing that simple alkyl, branched alkyl, cycloalkyl, functionalized alkyl, alkenyl, aryl or heteroaryl substituents ( $R^2$  or  $R^3$ ) can be introduced into the resulting  $\beta$ -ketoenamides **KE**. The use of  $\alpha,\beta$ -unsaturated nitriles as second component did not provide reasonable results, possibly due to a competing 1,4-addition of the lithiated methoxyallene to the double bonds. On the other hand,  $\alpha,\beta$ -unsaturated carboxylic acids were excellent third components as shown in various examples (Table 1, entries 15–19, 26–28, and 34). Even with acrylic acid the expected product **KE15** was isolated in 91% yield. Although we did not systematically study nitriles with heterocyclic substituents, we showed that thiophene-2-carbonitrile is an excellent substrate leading to **KE32–35** in good yields (Table 1, entries 32–35). Unfortunately, pyridine-2-carbonitrile could not be used as electrophilic component; the reason for this failure is unclear. By use of heterocyclic carboxylic acids we could smoothly introduce 2-thienyl and 2-pyridyl substituents into the  $\beta$ -ketoenamides **KE2**, **KE23**, **KE30**, **KE31** and **KE35** (Table 1, entries 2, 23, 30, 31, and 35).

The present approach does not allow the synthesis of  $\beta$ -ketoenamides with substituents  $R^2 = \text{H}$  or  $R^3 = \text{H}$ . The reaction of lithiated methoxyallene with hydrogen cyanide as second component was not examined due to the assumed Brønsted acid property of the latter. As a substitute, cyano trimethylsilane was examined, however, this experiment did not afford the corresponding  $\beta$ -ketoenamide. Unexpectedly, using formic acid as the third component afforded only mixtures of compounds whose structures could not be elucidated. The role of formic acid in the three-component reaction should be investigated by finding the proper substrates and conditions. The  $\beta$ -ketoenamides with *N*-formyl substituents should be valuable precursors for subsequent transformations.



**Scheme 4:** Synthesis of  $\beta$ -ketoenamides **KE** by the LANCA three-component reaction of alkoxyallenes, nitriles and carboxylic acids.

**Table 1:** Synthesis of  $\beta$ -ketoenamides **KE1–35** through the LANCA three-component reaction of lithiated methoxyallene, nitriles ( $R^2$ -CN) and carboxylic acids ( $R^3$ -CO<sub>2</sub>H) according to Scheme 4.<sup>a</sup>

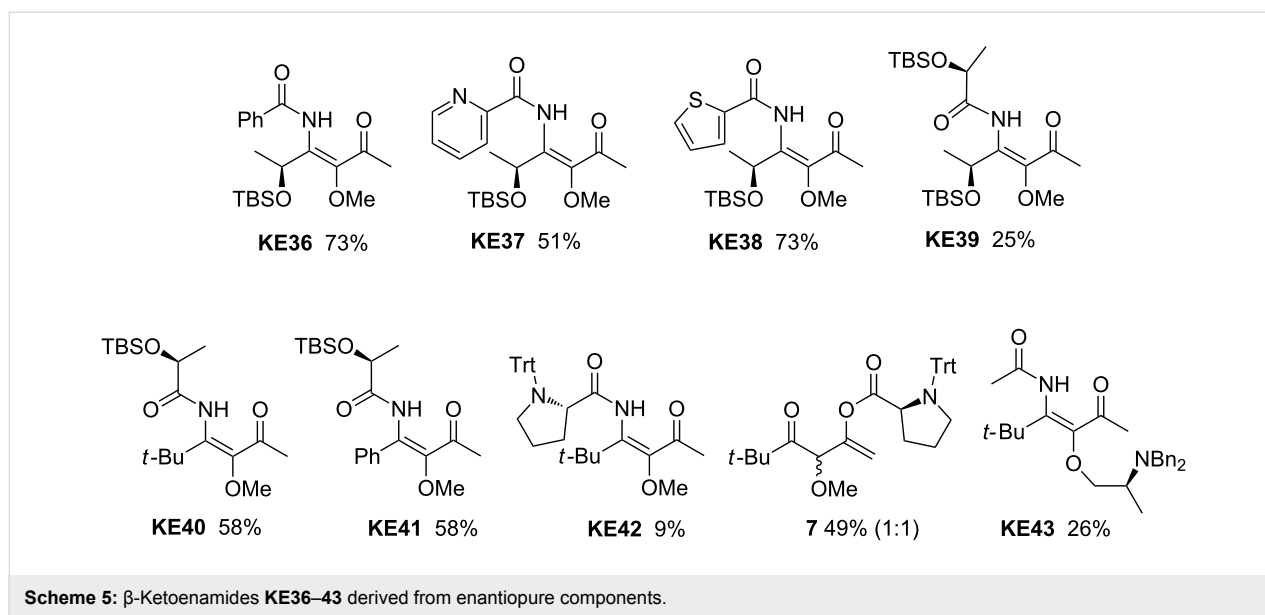
entry	R <sup>1</sup>	R <sup>2</sup>	R <sup>3</sup>	product	yield	ref.
1	Me	Me	Ph	<b>KE1</b>	13%	[27]
2	Me	Me	2-Py	<b>KE2</b>	22%	[27]
3	Me	iPr	CCl <sub>3</sub>	<b>KE3</b>	41% (+9% <b>Py</b> )	[28]
4	Me	iPr	Ph	<b>KE4</b>	53%	[27]
5	Me	cPr	cPr	<b>KE5</b>	75%	[29]
6	Me	cPr	C <sub>6</sub> H <sub>4</sub> -4-Br	<b>KE6</b>	53%	[30]
7	Me	<i>t</i> -Bu	allyl	<b>KE7</b>	82%	[31]
8	Me	<i>t</i> -Bu	Bn	<b>KE8</b>	95%	[31]
9	Me	<i>t</i> -Bu	cPr	<b>KE9</b>	39%	[30]
10	Me	<i>t</i> -Bu	CH <sub>2</sub> CH <sub>2</sub> SiMe <sub>3</sub>	<b>KE10</b>	49%	[30]
11	Me	<i>t</i> -Bu	CH <sub>2</sub> OPh	<b>KE11</b>	63%	[27]
12	Me	<i>t</i> -Bu	CF <sub>3</sub>	<b>KE12</b>	27% (+15% <b>Py</b> )	[21]
13	Me	<i>t</i> -Bu	CH <sub>2</sub> Cl	<b>KE13</b>	60%	[30]
14	Me	<i>t</i> -Bu	CCl <sub>3</sub>	<b>KE14</b>	27% (+28% <b>Py</b> )	[28]
15	Me	<i>t</i> -Bu	HC=CH <sub>2</sub>	<b>KE15</b>	91%	[31]
16	Me	<i>t</i> -Bu	HC=CH-Me	<b>KE16</b>	93%	[31]
17	Me	<i>t</i> -Bu	HC=CH-Ph	<b>KE17</b>	87%	[31]
18	Me	<i>t</i> -Bu	HC=CH-2-Fu	<b>KE18</b>	89%	[31]
19	Me	<i>t</i> -Bu	HC=CH-2-Th	<b>KE19</b>	80%	[31]
20	Me	<i>t</i> -Bu	C $\equiv$ CH	<b>KE20</b>	72%	[27]
21	Me	<i>t</i> -Bu	Ph	<b>KE21</b>	76%	[27]
22	Me	Ad	cPr	<b>KE22</b>	67%	[32]
23	Me	CH <sub>2</sub> OMe	2-Py	<b>KE23</b>	33%	[27]
24	Me	Ph	CF <sub>3</sub>	<b>KE24</b>	30% (+28% <b>Py</b> )	[21]
25	Me	Ph	CCl <sub>3</sub>	<b>KE25</b>	42%	[28]
26	Me	Ph	CH=CH <sub>2</sub>	<b>KE26</b>	45%	[31]
27	Me	Ph	HC=CH-Ph	<b>KE27</b>	51%	[31]
28	Me	Ph	HC=CH-2-Th	<b>KE28</b>	68%	[31]
29	Me	Ph	Ph	<b>KE29</b>	45%	[29]
30	Me	Ph	2-Py	<b>KE30</b>	42%	[33]
31	Me	Ph	2-Th	<b>KE31</b>	43%	[27]
32	Me	2-Th	CH <sub>2</sub> OMe	<b>KE32</b>	47%	[27]
33	Me	2-Th	CH <sub>2</sub> Cl	<b>KE33</b>	62%	[30]
34	Me	2-Th	HC=CH-Ph	<b>KE34</b>	68%	[31]
35	Me	2-Th	2-Th	<b>KE35</b>	70%	[34]

<sup>a</sup>Abbreviations: Ad = 1-adamantyl, Fu = furyl, Py = pyridyl, Th = thienyl; all alkenyl substituents are *E*-configured.

As expected, the reactions involving trifluoroacetic acid gave only low yields of the  $\beta$ -ketoenamides **KE** due to the competing in situ cyclization to the corresponding pyridin-4-ols (**Py**, Table 1, entries 12 and 24). The related reactions with trichloroacetic acid provided the  $\beta$ -ketoenamides in slightly better yields with lower amounts of the corresponding pyridin-4-ols (Table 1, entries 3, 14, and 25) showing that the electrophilicity of the amide carbonyl group is lower in these substrates.

Stereogenic centers could also successfully be introduced into the  $\beta$ -ketoenamides as shown by the examples collected in

Scheme 5. All three possibilities to use enantiopure starting materials were examined in the three-component reaction. The products **KE36–39** are derived from the O-protected nitrile obtained from (*S*)-lactic acid [35,36]. This chiral acid itself was incorporated as third component resulting in  $\beta$ -ketoenamides **KE39–41**. There is no indication of an erosion of the enantiopurity and the chiral compounds were converted into the corresponding pyridin-4-ol derivatives and tested as chiral ligands in asymmetric catalysis [37]. Using the *N*-trityl-substituted proline as carboxylic acid provided the expected  $\beta$ -ketoenamide **KE42** in low yield and as major product we isolated compound **7** in 49% yield (1:1 mixture of the two possible diastereomers).



Probably due to the bulkiness of the acyl group, the migration to the nitrogen is strongly hampered and hence the three-component cascade almost completely stops at the stage of aminobutadiene **C** (see Scheme 2) that is hydrolyzed during work-up to give  $\alpha$ -methoxy carbonyl compound **7**. The isolation of this compound supports our mechanistic proposal as shown in Scheme 2 and it shows that sterically very hindered carboxylic acids are probably poor components in the route to  $\beta$ -ketoenamides. A systematic study of this possible limitation was not carried out, but a component such as Mosher acid with a tertiary carbon next to the carboxylic acid function was successfully used in the three-component reaction and the corresponding  $\beta$ -ketoenamide was converted into the corresponding pyridin-4-ol in good overall yield [36]. This demonstrates that carboxylic acids with tertiary centers are possible candidates for the route to  $\beta$ -ketoenamides.

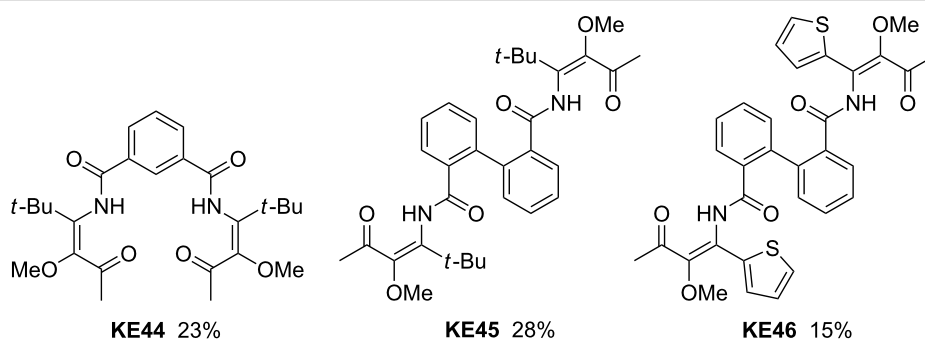
The last example shown in Scheme 5 demonstrates that allenes with chiral alkoxy substituents are also suitable starting materials in the three-component reaction. We did not study lithiated carbohydrate-derived alkoxyallenes that were good precursors for other applications [38,39], but prepared the allene derived from *N*-protected alaninol that was converted into  $\beta$ -ketoenamide **KE43** in 26% yield [30].

It should be mentioned here that most of the reactions to  $\beta$ -ketoenamides were performed only once under standard conditions without detailed optimization reaction conditions such as stoichiometry of components, applied temperatures and reaction times. It is therefore very likely that in the cases where low or moderate yields were recorded improvements are easily possible. For a few examples, we also performed the reactions

in larger scale, e.g., the synthesis of  $\beta$ -ketoenamides **KE35** that was prepared in 3.5 g quantity [34]. The scalability of the three-component reactions seems therefore no problem which is important for the multistep preparation of subsequent products (see below).

Aromatic dinitriles such as 1,3- and 1,4-dicyanobenzene were also examined as second component in the three-component reaction. The obtained bis- $\beta$ -ketoenamides were not isolated and purified, but directly converted into the corresponding bispyridin-4-ol derivatives by cyclocondensation [40]. The overall yields were only in the range of 20% probably due to solubility problems with employed aromatic dinitriles. Nevertheless, these examples showed the feasibility of this approach to highly substituted  $\beta$ -ketoenamides. Similar results were obtained by the use of aromatic dicarboxylic acids (Scheme 6). Again, the moderate efficacy may be due to their low solubility in ethereal solvents at low temperatures – a problem that could only partially be solved by use of DMF as cosolvent. The yields of  $\beta$ -ketoenamides **KE44–46** are only in the range of 25%, but the three-component approach to unique multifunctional products is nevertheless remarkable [41].

For subsequent reactions, alkoxy groups other than the methoxy group were desirable because the latter substituent can only be converted into free hydroxy groups by treatment with strong (Lewis) acids. We therefore examined benzyloxyallene as starting material in the three-component reaction to  $\beta$ -ketoenamides. The resulting products were deprotectable under milder conditions as shown below. The examples, including one with a *p*-methoxybenzyloxy group (PMB, Table 2, entry 10) are collected in Table 2. As expected there were no fundamental



**Scheme 6:** Bis- $\beta$ -ketoenamides **KE44–46** derived from aromatic dicarboxylic acids.

**Table 2:** Synthesis of  $\beta$ -ketoenamides **KE47–56** through the LANCA three-component reaction of lithiated benzyloxyallene, nitriles ( $R^2$ -CN) and carboxylic acids ( $R^3$ -CO<sub>2</sub>H) according to Scheme 4.<sup>a</sup>

entry	R <sup>1</sup>	R <sup>2</sup>	R <sup>3</sup>	product	yield	ref.
1	Bn	Me	CF <sub>3</sub>	<b>KE47</b>	5% (+39% <b>PY</b> )	[22]
2	Bn	<i>n</i> -Non	Ph	<b>KE48</b>	27%	[42]
3	Bn	cPr	cPr	<b>KE49</b>	56%	[27]
4	Bn	<i>t</i> -Bu	cPr	<b>KE50</b>	44%	[30]
5	Bn	<i>t</i> -Bu	2-Th	<b>KE51</b>	52%	[42]
6	Bn	Ph	CF <sub>3</sub>	<b>KE52</b>	40% (+36% <b>PY</b> )	[42]
7	Bn	Ph	Ph	<b>KE53</b>	54%	[29]
8	Bn	Ph	2-Py	<b>KE54</b>	27%	[42]
9	Bn	2-Th	2-Th	<b>KE55</b>	32%	[27]
10	PMB	Ph	CF <sub>3</sub>	<b>KE56</b>	23% (+10% <b>PY</b> )	[42]

<sup>a</sup>Abbreviations: Fu = furyl, Py = pyridyl, Th = thienyl, PMB = CH<sub>2</sub>C<sub>6</sub>H<sub>4</sub>-4-OMe; all alkenyl substituents are *E*-configured.

differences to the observations with methoxyallene. The  $\beta$ -ketoenamides derived from trifluoroacetic acid are only available in low yield due to the fast formation of the corresponding pyridin-4-ols (**PY**, Table 2, entries 1, 6, and 10). For the other combinations of substituents the unoptimized yields of  $\beta$ -ketoenamides are satisfying.

Another good alternative to methoxyallene is the 2-(trimethylsilyl)ethoxy-substituted allene. The 2-(trimethylsilyl)ethyl substituent can be removed from the products either by fluoride or acid treatment under mild conditions. Again, there were no great differences in the performance of this component compared to methoxyallene or benzyloxyallene. In Table 3 the result with tetrahydropyranyl-substituted allene is also included (Table 3, entry 1) that gave a moderate yield of  $\beta$ -ketoenamide **KE57**.

The alkoxyallenes so far listed are unsubstituted at the C-3 terminus and related allenes bearing alkyl groups at this carbon are not directly accessible [44]. In contrast, products that are formally derived from 3-aryl-substituted alkoxyallenes can

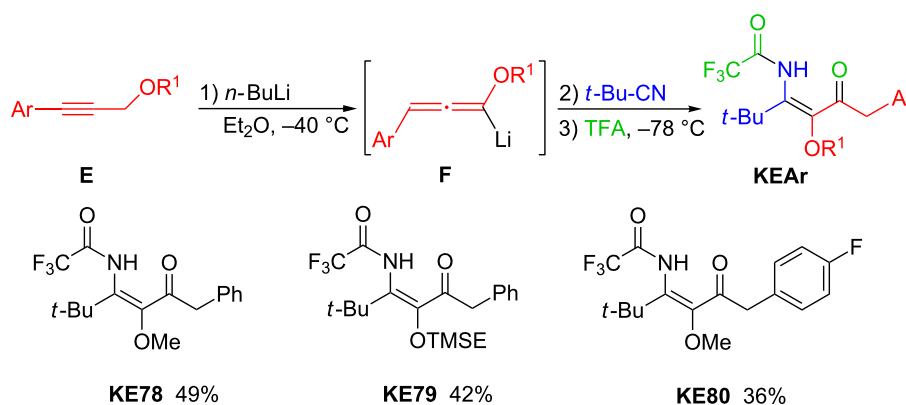
smoothly be prepared from the corresponding alkyl propargyl ethers **E** (Scheme 7). Their deprotonation with *n*-butyllithium proceeds with a proton shift delivering the intermediate **F** that reacts with electrophiles at C-1. The three-component reaction with nitriles and carboxylic acids then leads to the corresponding  $\beta$ -ketoenamides **KEAr** in moderate yields. The reaction sequence is illustrated in Scheme 7 also showing the three products **KE78** [22], **KE79** [45] and **KE80** [46] that were prepared by this largely unexplored, but very promising method. It opens a route to highly substituted heterocycles as shown by the cyclocondensation of **KE78** that gave the corresponding penta-substituted pyridin-4-ol derivative in 91% yield [22].

As mentioned above, a large number of the prepared  $\beta$ -ketoenamides **KE** was converted into the corresponding pyridin-4-ol derivatives **PY** and subsequent products of these versatile heterocyclic intermediates. Our published review on this topic [23] presents many examples of  $\beta$ -ketoenamides **KE** that were not purified but directly transferred into these pyridine derivatives. Hence, the scope of available  $\beta$ -ketoenamides **KE** is broader than the eighty examples presented here. This fact

**Table 3:** Synthesis of  $\beta$ -ketoenamides **KE57–77** by the LANCA three-component reaction of lithiated 2-(trimethylsilyl)ethoxyallene, nitriles ( $R^2$ -CN) and carboxylic acids ( $R^3$ -CO<sub>2</sub>H) according to Scheme 4.<sup>a</sup>

entry	R <sup>1</sup>	R <sup>2</sup>	R <sup>3</sup>	product	yield	ref.
1	2-THP	cPr	cPr	<b>KE57</b>	24%	[42]
2	TMSE	cPr	cPr	<b>KE58</b>	75%	[42]
3	TMSE	cPr	CH=CH-Ph	<b>KE59</b>	57%	[30]
4	TMSE	<i>t</i> -Bu	Me	<b>KE60</b>	52%	[42]
5	TMSE	<i>t</i> -Bu	CF <sub>3</sub>	<b>KE61</b>	14% (+28% PY)	[33]
6	TMSE	<i>t</i> -Bu	HC=CH <sub>2</sub>	<b>KE62</b>	40%	[43]
7	TMSE	<i>t</i> -Bu	HC=CH-Me	<b>KE63</b>	42%	[43]
8	TMSE	<i>t</i> -Bu	HC=CH-Ph	<b>KE64</b>	35%	[43]
9	TMSE	<i>t</i> -Bu	HC=CH-C <sub>6</sub> H <sub>4</sub> -NO <sub>2</sub>	<b>KE65</b>	52%	[43]
10	TMSE	<i>t</i> -Bu	HC=CH-2-Fu	<b>KE66</b>	30%	[43]
11	TMSE	<i>t</i> -Bu	Ph	<b>KE67</b>	49% <sup>b</sup>	[30]
12	TMSE	Ad	cPr	<b>KE68</b>	57%	[42]
13	TMSE	Ph	CF <sub>3</sub>	<b>KE69</b>	39% (+24% PY)	[42]
14	TMSE	Ph	HC=CH-Me	<b>KE70</b>	46%	[43]
15	TMSE	Ph	HC=CH-Ph	<b>KE71</b>	50%	[43]
16	TMSE	Ph	C $\equiv$ CH	<b>KE72</b>	21%	[42]
17	TMSE	Ph	Ph	<b>KE73</b>	36%	[29]
18	TMSE	Ph	2-Py	<b>KE74</b>	24%	[42]
19	TMSE	Ph	2-Th	<b>KE75</b>	75%	[42]
20	TMSE	Ph	Ac	<b>KE76</b>	28%	[42]
21	TMSE	2-Th	Ph	<b>KE77</b>	74%	[29]

<sup>a</sup>Abbreviations: THP = tetrahydropyranyl, Ad = 1-adamantyl, Fu = furyl, Py = pyridyl, Th = thienyl; all alkenyl substituents are *E*-configured. <sup>b</sup>As second product, 15% of the imine tautomer of  $\beta$ -ketoenamide **KE67** was isolated.

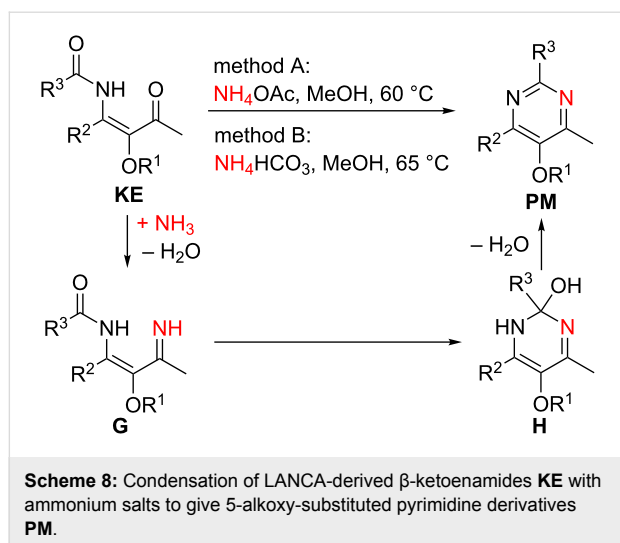
**Scheme 7:** Conversion of alkyl propargyl ethers **E** into aryl-substituted  $\beta$ -ketoenamides **KEAr** and selected products **KE78–80** obtained by this route.

should be kept in mind when the reactions of  $\beta$ -ketoenamides to alternative subsequent products are discussed in the following chapters.

### Synthesis of pyrimidine derivatives

The  $\beta$ -ketoenamides **KE** also serve as excellent starting materials for the preparation of highly substituted pyrimidine derivatives **PM** [47-49]. Cyclocondensation reactions with ammonium salts in methanol afford these versatile heterocycles in good

to excellent yields (Scheme 8). In most cases, ammonium acetate gave the best results (method A) and in a few examples ammonium bicarbonate was tested as alternative (method B) [29,33]. The plausible mechanism of this transformation involves the formation of an  $\alpha,\beta$ -unsaturated imine **G** and its cyclization to **H** followed by water elimination. As characteristic substitution pattern, the available pyrimidines **PM** contain a methyl group at C-4 and an alkoxy group OR<sup>1</sup> at C-5.



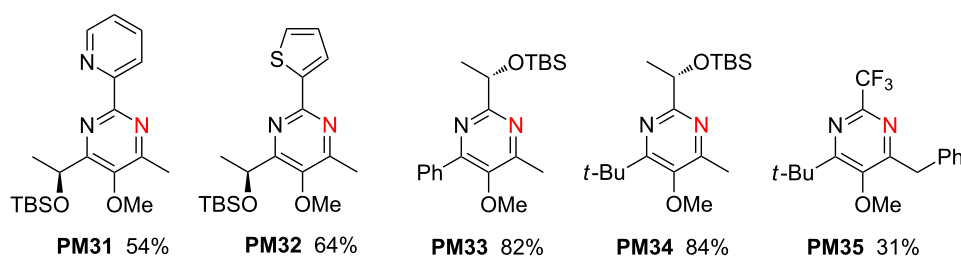
The remarkably wide scope of this pyrimidine synthesis is demonstrated by the thirty examples collected in Table 4. All tested  $\beta$ -ketoenamides were successfully converted into the pyrimidines **PM** and the examples show that the method is fully compatible with methoxy, benzyloxy and 2-(trimethylsilyl)ethoxy substituents. The groups  $R^2$  and  $R^3$  can be unbranched, branched or functionalized alkyl, aryl or heteroaryl groups. In addition, there are many examples with alkenyl substituents  $R^3$ .

In Scheme 9 additional examples **PM31–34** having stereogenic centers are presented, that were obtained from  $\beta$ -ketoenamides **KE37**, **KE38**, **KE40** and **KE41** (see Scheme 5) [43]. The pyrimidine **PM35** is derived from  $\beta$ -ketoenamide **KE78** (see Scheme 7) and bears a benzyl group at C-4 instead of the standard methyl group [33].

**Table 4:** Condensation of  $\beta$ -ketoenamides **KE** with ammonium salts to give pyrimidine derivatives **PM1–30** according to Scheme 8.<sup>a</sup>

entry	precursor	$R^1$	$R^2$	$R^3$	product	yield (method) <sup>b</sup>	ref.
1	<b>KE1</b>	Me	Me	Ph	<b>PM1</b>	40% (A)	[33]
2	<b>KE4</b>	Me	iPr	Ph	<b>PM2</b>	54% (A)	[33]
3	<b>KE5</b>	Me	cPr	cPr	<b>PM3</b>	56% (A)	[29]
4	<b>KE7</b>	Me	<i>t</i> -Bu	allyl	<b>PM4</b>	69% (A)	[31]
5	<b>KE8</b>	Me	<i>t</i> -Bu	Bn	<b>PM5</b>	82% (A)	[50]
6	<b>KE12</b>	Me	<i>t</i> -Bu	CF <sub>3</sub>	<b>PM6</b>	31% (A)	[33]
7	<b>KE15</b>	Me	<i>t</i> -Bu	HC=CH <sub>2</sub>	<b>PM7</b>	77% (A)	[31]
8	<b>KE16</b>	Me	<i>t</i> -Bu	HC=CH-Me	<b>PM8</b>	75% (A)	[31]
9	<b>KE17</b>	Me	<i>t</i> -Bu	HC=CH-Ph	<b>PM9</b>	85% (A)	[31]
10	<b>KE18</b>	Me	<i>t</i> -Bu	HC=CH-2-Fu	<b>PM10</b>	67% (A)	[31]
11	<b>KE19</b>	Me	<i>t</i> -Bu	HC=CH-2-Th	<b>PM11</b>	69% (A)	[31]
12	<b>KE20</b>	Me	<i>t</i> -Bu	C $\equiv$ CH	<b>PM12</b>	55% (A)	[33]
13	<b>KE26</b>	Me	Ph	HC=CH <sub>2</sub>	<b>PM13</b>	55% (A)	[31]
14	<b>KE27</b>	Me	Ph	HC=CH-Ph	<b>PM14</b>	84% (A)	[31]
15	<b>KE29</b>	Me	Ph	Ph	<b>PM15</b>	73% (A), 66% (B)	[29]
16	<b>KE30</b>	Me	Ph	2-Py	<b>PM16</b>	38% (A)	[33]
17	<b>KE31</b>	Me	Ph	2-Th	<b>PM17</b>	65% (B)	[33]
18	<b>KE34</b>	Me	2-Th	HC=CH-Ph	<b>PM18</b>	78% (A)	[31]
19	<b>KE35</b>	Me	2-Th	2-Th	<b>PM19</b>	83% (A)	[50]
20	<b>KE53</b>	Bn	Ph	Ph	<b>PM20</b>	75% (B)	[29]
21	<b>KE55</b>	Bn	2-Th	2-Th	<b>PM21</b>	68% (A)	[33]
22	<b>KE61</b>	TMSE	<i>t</i> -Bu	CF <sub>3</sub>	<b>PM22</b>	66% (B)	[33]
23	<b>KE62</b>	TMSE	<i>t</i> -Bu	HC=CH <sub>2</sub>	<b>PM23</b>	53% (A)	[43]
24	<b>KE63</b>	TMSE	<i>t</i> -Bu	HC=CH-Me	<b>PM24</b>	70% (A)	[43]
25	<b>KE64</b>	TMSE	<i>t</i> -Bu	HC=CH-Ph	<b>PM25</b>	52% (A)	[43]
26	<b>KE66</b>	TMSE	<i>t</i> -Bu	HC=CH-2-Fu	<b>PM26</b>	65% (A)	[43]
27	<b>KE70</b>	TMSE	Ph	HC=CH-Me	<b>PM27</b>	66% (A)	[43]
28	<b>KE71</b>	TMSE	Ph	HC=CH-Ph	<b>PM28</b>	68% (A)	[43]
29	<b>KE73</b>	TMSE	Ph	Ph	<b>PM29</b>	86% (A)	[29]
30	<b>KE77</b>	TMSE	2-Th	Ph	<b>PM30</b>	74% (B)	[29]

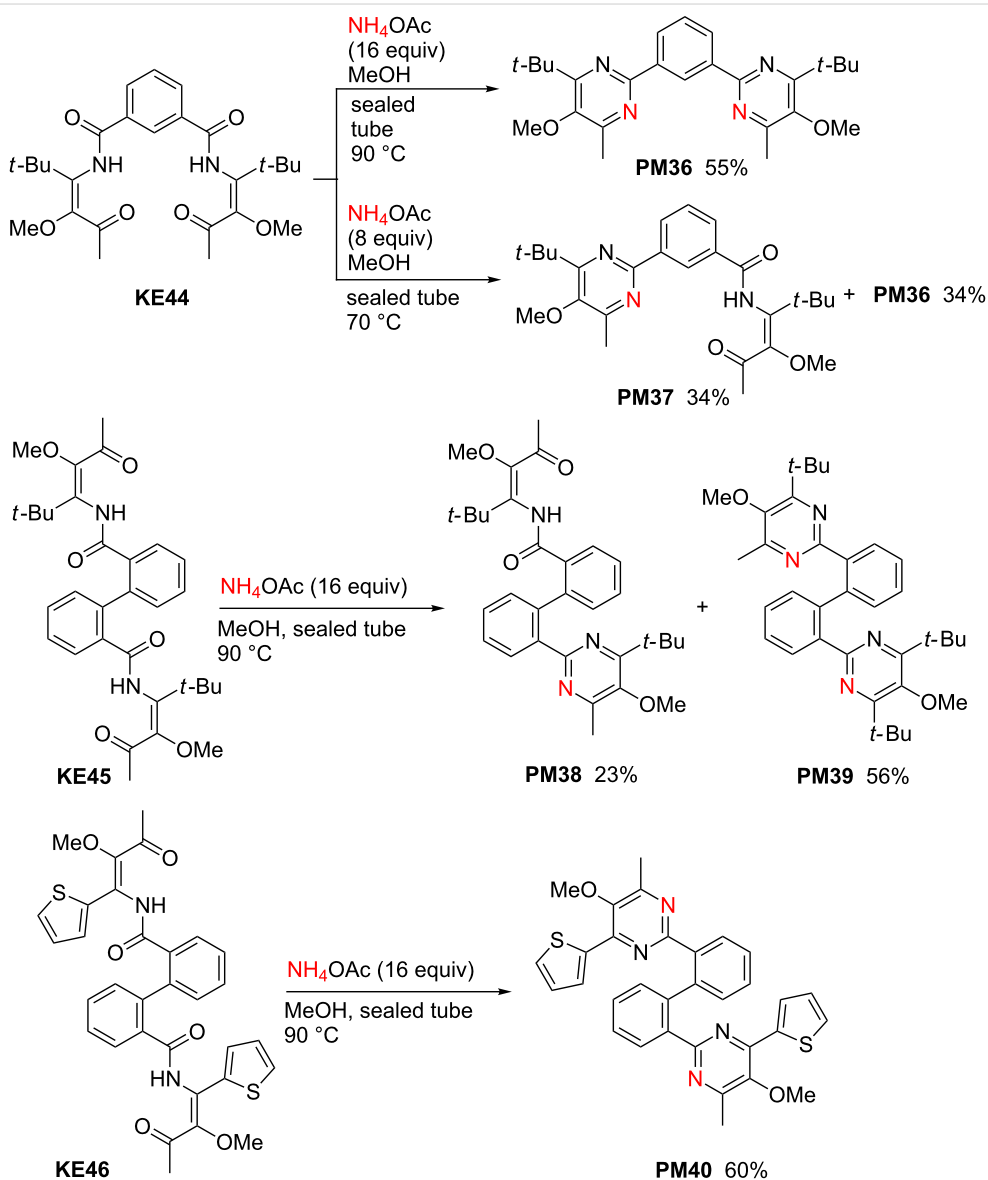
<sup>a</sup>Abbreviations: Fu = furyl, Py = pyridyl, Th = thienyl; all alkenyl substituents are *E*-configured. <sup>b</sup>Method A: NH<sub>4</sub>OAc, MeOH, 60 °C; method B: NH<sub>4</sub>HCO<sub>3</sub>, MeOH, 65 °C.



**Scheme 9:** Synthesis of **PM31–35** from  $\beta$ -ketoenamides **KE37**, **KE38**, **KE40**, **KE41** and **KE78** obtained by method A ( $\text{NH}_4\text{OAc}$ , MeOH, 60 °C).

The bis- $\beta$ -ketoenamides **KE44–46** also provide the expected bis-pyrimidine derivatives (Scheme 10) [41]. With precursor **KE44** a full conversion into the expected bis-pyrimidine prod-

uct **PM36** was achieved in 55% yield after 48 h reaction time, when a large excess of ammonium acetate (16 equiv) is employed, whereas with only eight equivalents (reaction time:

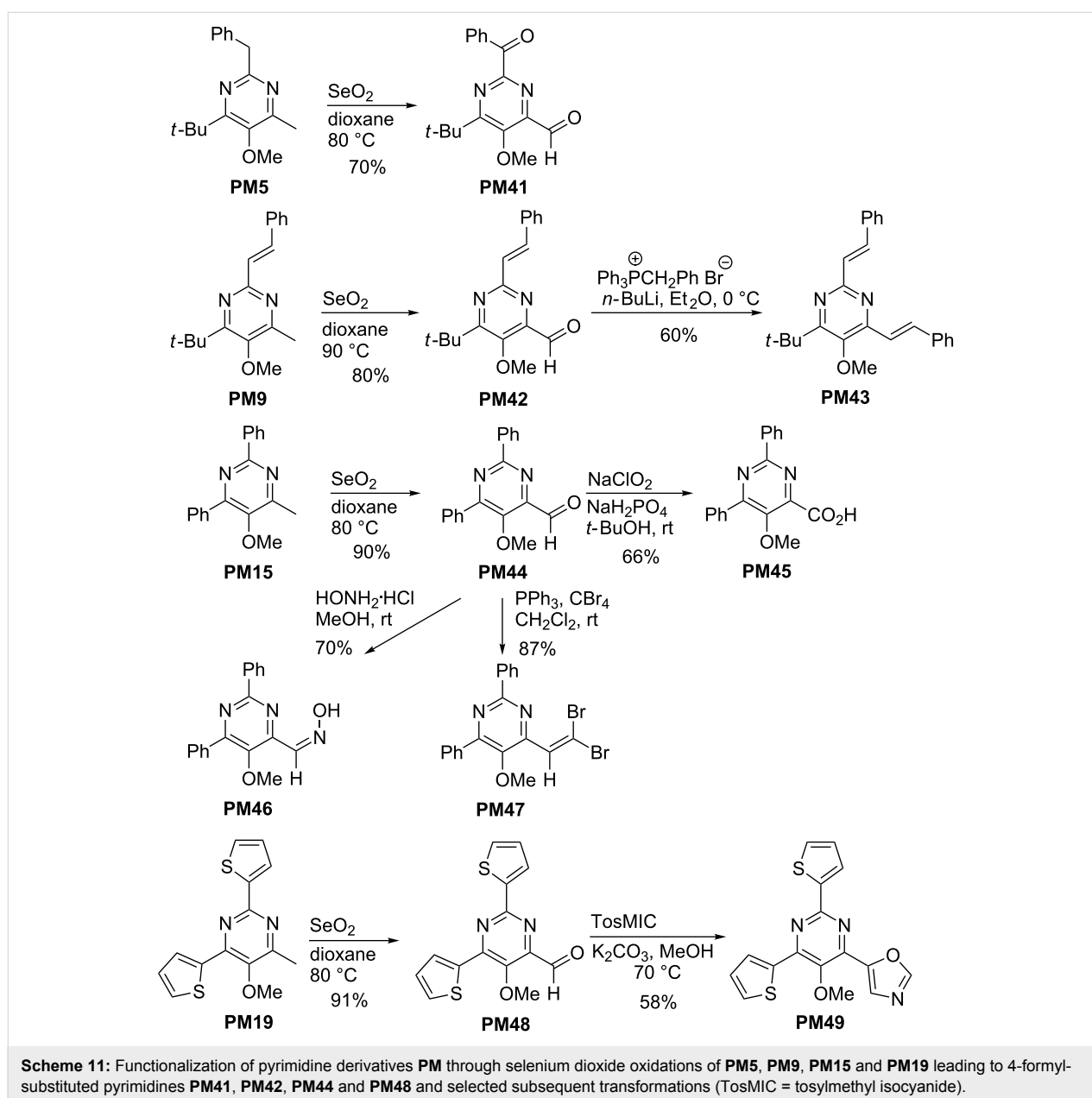


**Scheme 10:** Synthesis of bis-pyrimidine derivatives **PM36**, **PM39** and **PM40** from  $\beta$ -ketoenamides **KE44–46** by method A ( $\text{NH}_4\text{OAc}$ , MeOH, 60 °C).

36 h) a 1:1 mixture of **PM36** and the intermediate mono-pyrimidine **PM37** – containing still one  $\beta$ -ketoamide moiety – was isolated. The use of sixteen equivalents ammonium acetate afforded good yields of bis-pyrimidine derivative **PM39** and **PM40**, whereas in the case of **KE45** as starting material, considerable amounts of the mono-pyrimidine derivative **PM38** were isolated as side product. Subsequently, both mono-pyrimidine derivatives **PM37** and **PM38** were subjected to alternative cyclization reactions involving the remaining  $\beta$ -ketoamide moiety [41]. It is worth mentioning that the relatively complex heterocyclic compounds depicted in Scheme 10 are accessible through the three-component reaction and subsequent condensation reaction in only two steps.

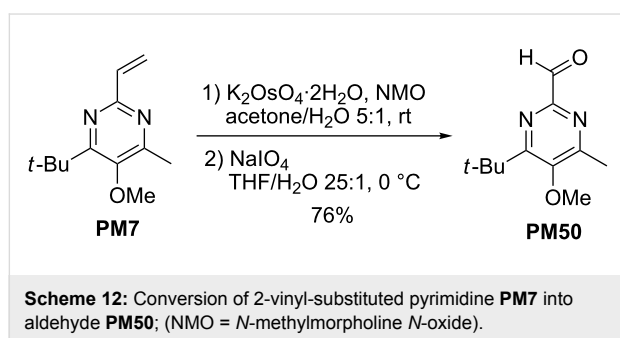
## Functionalization of pyrimidine derivatives

The substitution pattern of the prepared pyrimidine derivatives **PM** allows a variety of subsequent transformations to new derivatives. The C-4 methyl (in one case benzyl) group is an inevitable structural feature of these pyrimidines, but it can smoothly be used for oxidation reactions to introduce new functional groups. As typical examples selenium dioxide oxidations of **PM5**, **PM9**, **PM15** and **PM19** furnishing aldehydes **PM41**, **PM42**, **PM44** and **PM48** are shown in Scheme 11 [33]. In case of the benzyl-substituted substrate **PM5**, the (probably faster) oxidation of the C-2 benzyl group could not be avoided and hence the dicarbonyl compound **PM41** was isolated [50]. The formyl group of the prepared intermediates allows further



conversion into other functional groups as depicted in the scheme. Wittig reactions provided 4-alkenyl-substituted pyrimidine derivatives such as **PM43** or **PM47**, whereas further oxidation of **PM44** afforded the carboxylic acid **PM45** in good yield [33]. Alternatively, the conversion of **PM44** into oxime **PM46** or a van Leusen oxazole synthesis [51] of **PM48** with tosylmethyl isocyanide giving **PM49** were possible. The synthesis of pyrimidine derivative **PM49** with three heterocyclic substituents is remarkable and stresses the flexibility of the methods presented here.

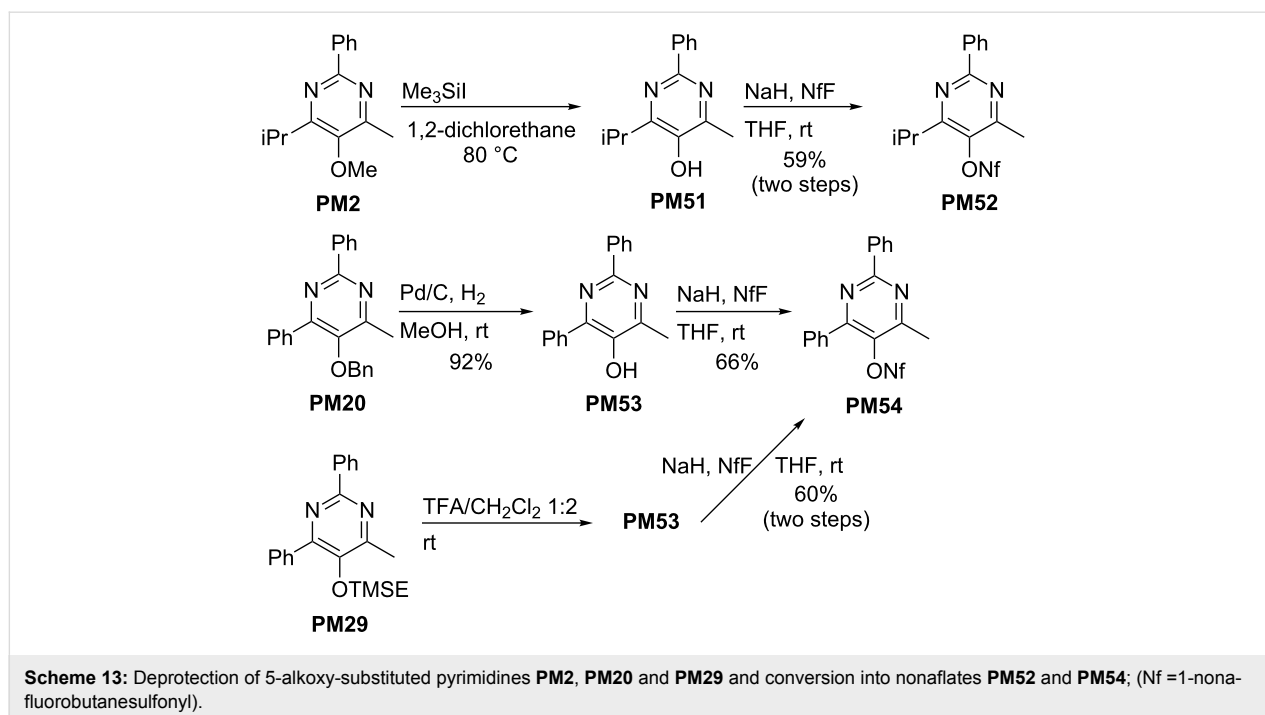
The easily introduced C-2 alkenyl groups may also be oxidized. Thus, dihydroxylation of the vinyl group in **PM7** followed by oxidative cleavage afforded pyrimidine derivative **PM50** having a formyl group at C-2 (Scheme 12) [31].

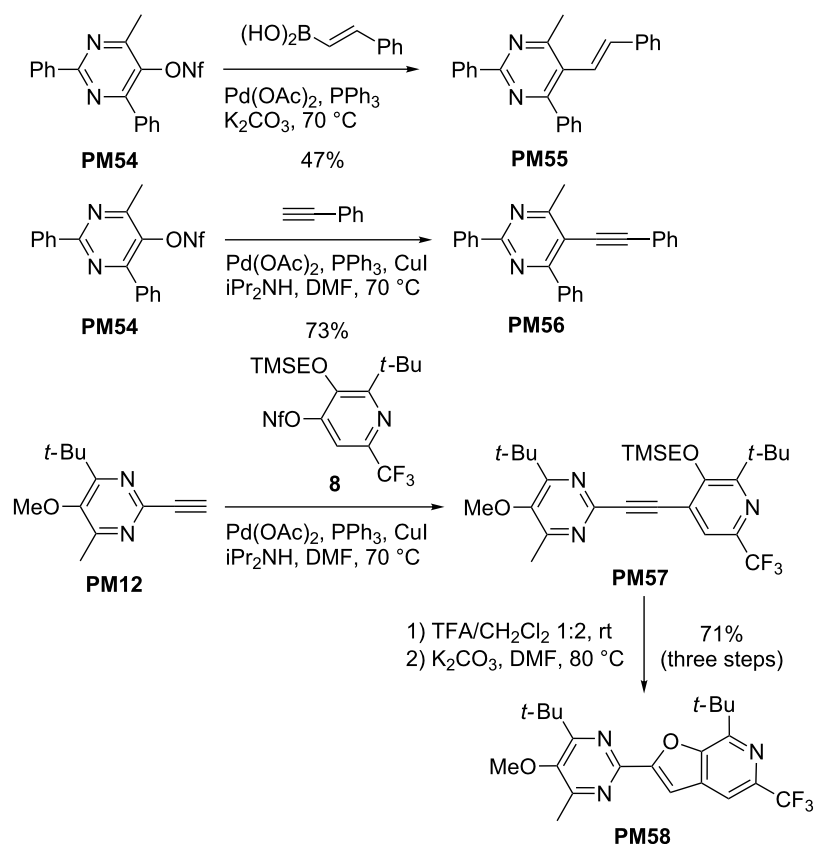


Next, the conversion of the 5-alkoxy groups of the pyrimidine derivatives **PM** into a 1-nonafluorobutanesulfonate group is

presented, that – like the closely related triflate group – allows transition metal-catalyzed coupling reactions or nucleophilic substitutions [52]. The selected three examples presented in Scheme 13 show striking differences in the deprotection step [33]. The methoxy-substituted compound **PM2** requires harsh conditions employing trimethylsilyl iodide at 80 °C to provide the intermediate hydroxy derivative **PM51**. In contrast, the removal of the benzyl group in **PM20** can be achieved by palladium-catalyzed hydrogenolysis at room temperature to give hydroxy compound **PM53**. This method is certainly not applicable to pyrimidines with alkenyl substituents, but in this case 2-(trimethylsilyl)ethoxy-substituted compounds such as **PM29** can be used, whose deprotection with trifluoroacetic acid proceeds at room temperature. The obtained 5-hydroxy-pyrimidines can be purified and characterized or, for further transformations, the crude products are directly converted into the corresponding nonaflates by deprotonation with sodium hydride and treatment with 1-nonafluorobutanesulfonyl fluoride (NfF). Scheme 13 shows two examples, **PM52** and **PM54** that are ready for palladium-catalyzed reactions.

As mentioned above, pyridyl nonaflates derived from the  $\beta$ -ketoenamides **KE** are excellent substrates for palladium-catalyzed coupling reactions as briefly discussed in our review [23]. Pyrimidyl nonaflates can analogously be used to achieve higher substitution degrees as illustrated by the examples shown in Scheme 14 [33]. Nonaflate **PM54** underwent a Suzuki–Miyaura reaction to **PM55** or a Sonogashira coupling to **PM56** under



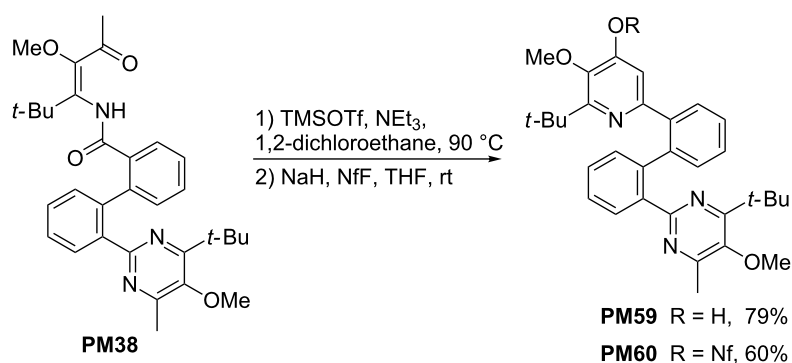


**Scheme 14:** Palladium-catalyzed coupling reactions of **PM54** and **PM12** giving rise to new pyrimidine derivatives **PM55–58**.

standard conditions. The ethynyl-substituted pyrimidine derivative **PM12** could also be employed in C–C coupling reactions as shown by its connection to pyridyl nonaflate **8** – readily available from  $\beta$ -ketoenamide **KE61** [33] – efficiently furnishing the disubstituted alkyne **PM57**. This intermediate was directly converted into pyrimidyl-substituted furopyridine derivative **PM58** in very good overall yield. The example of compound **PM58** nicely demonstrates the combination of different heterocycles that were generated from the two  $\beta$ -ketoen-

amides **KE20** and **KE61** and shows the potential of these methods in heterocyclic chemistry.

Options for palladium-catalyzed reactions are also offered by compound **PM60** that was prepared from mono-pyrimidyl-substituted  $\beta$ -ketoenamide **PM38** (see Scheme 10). This compound was converted into **PM59** by the standard cyclocondensation reaction (Scheme 15) leading to a pyridin-4-ol moiety that was converted to the nonaflate. Compound **PM60** bears a



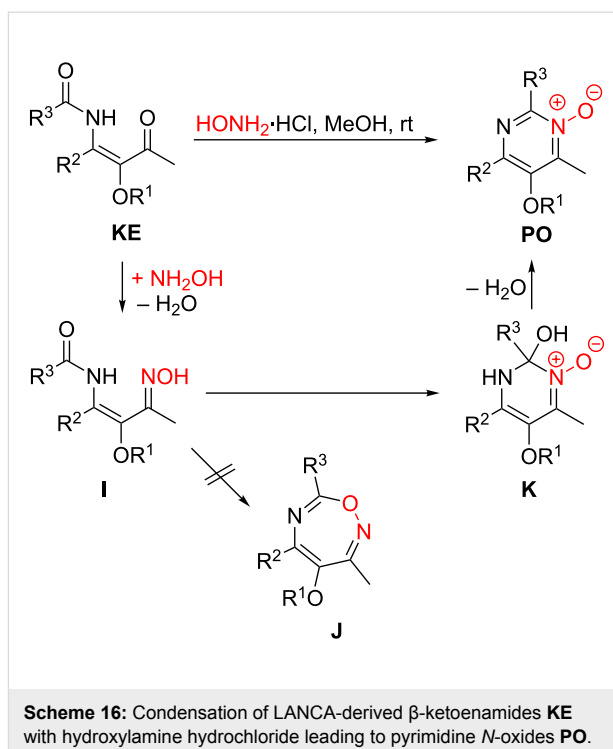
**Scheme 15:** Synthesis of pyrimidyl-substituted pyridyl nonaflate **PM60**.

pyrimidyl and a pyridinyl substituent at the 2,2'-position of the biphenyl part [41].

### Synthesis of pyrimidine *N*-oxide derivatives

The condensation of  $\beta$ -ketoenamides **KE** with hydroxylamine hydrochloride can either deliver pyrimidine *N*-oxides **PO** or oxazepine derivatives **J**. However, only the six-membered heterocycles were isolated under the conditions employed (Scheme 16) [32]. Remarkably, the condensations occurred under milder conditions compared with those involving ammonium salts and smoothly provided the pyrimidine *N*-oxides at room temperature. An additional advantage of this approach to the pyrimidine skeleton is the fact that the *N*-oxide moiety could be exploited for the functionalization of the adjacent 4-alkyl group.

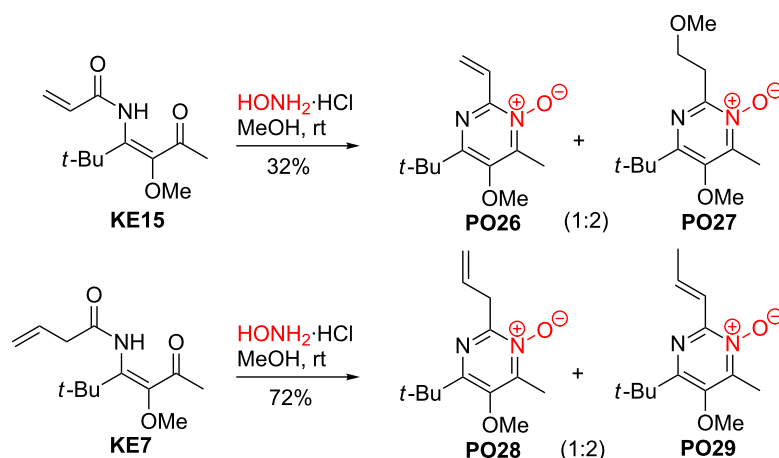
The scope of this method is again very broad as demonstrated by the 25 examples compiled in Table 5 and those of Scheme 17 and Scheme 18. This condensation method is compatible with all substituents that are available by the three-component reactions to  $\beta$ -ketoenamides **KE**, however, due to the slightly acidic reaction conditions the *tert*-butyldimethylsilyl



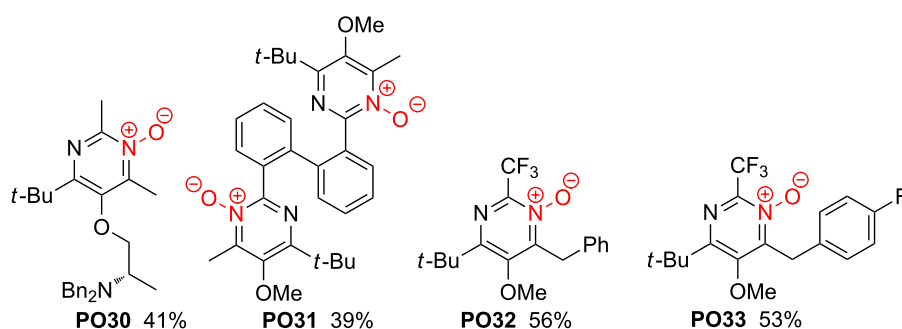
**Table 5:** Preparation of pyrimidine *N*-oxides **PO1–25** through condensation of  $\beta$ -ketoenamides **KE** with hydroxylamine hydrochloride.<sup>a</sup>

entry	precursor	R <sup>1</sup>	R <sup>2</sup>	R <sup>3</sup>	product	yield	ref.
1	<b>KE3</b>	Me	<i>i</i> Pr	CCl <sub>3</sub>	<b>PO1</b>	28%	[28]
2	<b>KE4</b>	Me	<i>i</i> Pr	Ph	<b>PO2</b>	61%	[32]
3	<b>KE6</b>	Me	<i>c</i> Pr	C <sub>6</sub> H <sub>4</sub> -4-Br	<b>PO3</b>	69%	[30]
4	<b>KE8</b>	Me	<i>t</i> -Bu	Bn	<b>PO4</b>	81%	[30]
5	<b>KE9</b>	Me	<i>t</i> -Bu	<i>c</i> Pr	<b>PO5</b>	54%	[53]
6	<b>KE10</b>	Me	<i>t</i> -Bu	CH <sub>2</sub> CH <sub>2</sub> SiMe <sub>3</sub>	<b>PO6</b>	46%	[30]
7	<b>KE40</b>	Me	<i>t</i> -Bu	CH(OH)Me	<b>PO7</b>	30%	[43]
8	<b>KE14</b>	Me	<i>t</i> -Bu	CCl <sub>3</sub>	<b>PO8</b>	71%	[28]
9	<b>KE16</b>	Me	<i>t</i> -Bu	HC=CH-Me	<b>PO9</b>	54%	[54]
10	<b>KE17</b>	Me	<i>t</i> -Bu	HC=CH-Ph	<b>PO10</b>	88%	[32]
11	<b>KE18</b>	Me	<i>t</i> -Bu	HC=CH-2-Fu	<b>PO11</b>	99%	[32]
12	<b>KE19</b>	Me	<i>t</i> -Bu	HC=CH-2-Th	<b>PO12</b>	91%	[32]
13	<b>KE21</b>	Me	<i>t</i> -Bu	Ph	<b>PO13</b>	97%	[32]
14	<b>KE22</b>	Me	Ad	<i>c</i> Pr	<b>PO14</b>	67%	[32]
15	<b>KE25</b>	Me	Ph	CCl <sub>3</sub>	<b>PO15</b>	96%	[28]
16	<b>KE27</b>	Me	Ph	HC=CH-Ph	<b>PO16</b>	58%	[54]
17	<b>KE29</b>	Me	Ph	Ph	<b>PO17</b>	58%	[30]
18	<b>KE34</b>	Me	2-Th	HC=CH-Ph	<b>PO18</b>	65%	[30]
19	<b>KE35</b>	Me	2-Th	2-Th	<b>PO19</b>	59%	[32]
20	<b>KE50</b>	Bn	<i>t</i> -Bu	<i>c</i> Pr	<b>PO20</b>	38%	[30]
21	<b>KE58</b>	TMSE	<i>c</i> Pr	<i>c</i> Pr	<b>PO21</b>	65%	[32]
22	<b>KE59</b>	TMSE	<i>c</i> Pr	HC=CH-Ph	<b>PO22</b>	45%	[30]
23	<b>KE63</b>	TMSE	<i>t</i> -Bu	HC=CH-Me	<b>PO23</b>	47%	[54]
24	<b>KE67</b>	TMSE	<i>t</i> -Bu	Ph	<b>PO24</b>	quant	[30]
25	<b>KE68</b>	TMSE	Ad	<i>c</i> Pr	<b>PO25</b>	84%	[32]

<sup>a</sup>Abbreviations: Ad = 1-adamantyl, Fu = furyl, Py = pyridyl, Th = thienyl; all alkenyl substituents are *E*-configured.



**Scheme 17:** Reactions of  $\beta$ -ketoenamides **KE15** and **KE7** with hydroxylamine hydrochloride leading to pyrimidine *N*-oxides **PO26–29**.



**Scheme 18:** Structures of pyrimidine *N*-oxides **PO30–33** derived from  $\beta$ -ketoenamides **KE43**, **KE45**, **KE78** and **KE80**.

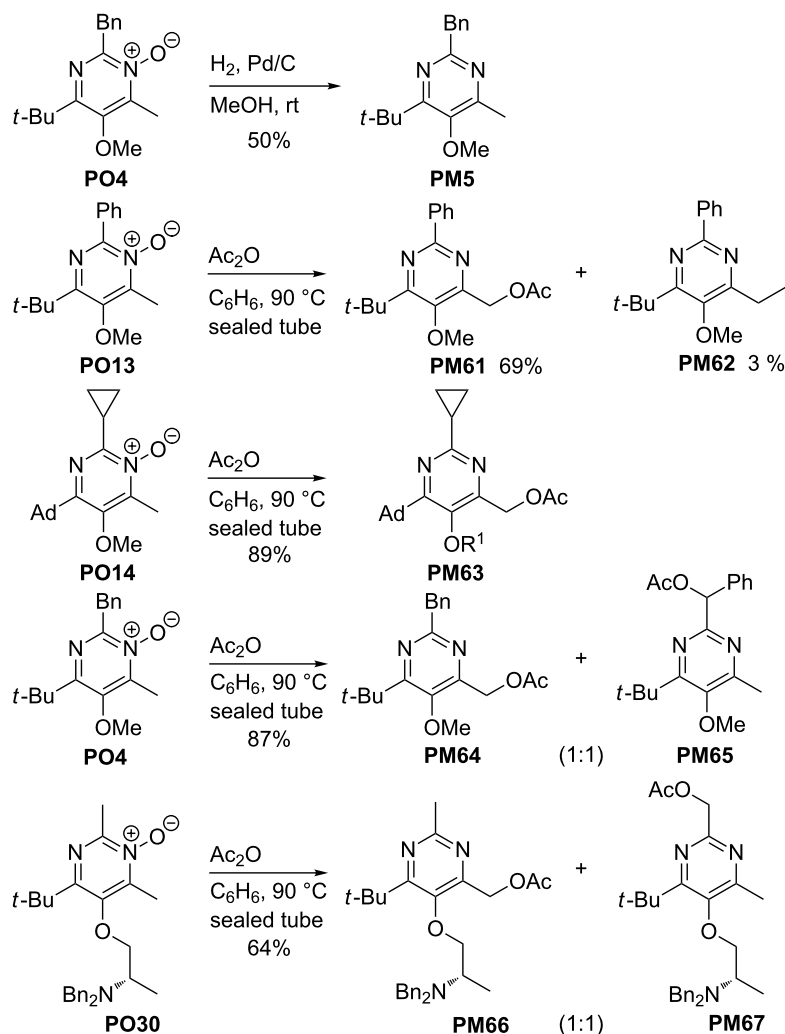
protection group of **KE40** is removed during the formation of **PO7** (Table 5, entry 7).

Under the conditions applied the vinyl-substituted  $\beta$ -ketoenamide **KE15** furnished the expected pyrimidine *N*-oxide **PO26**. However, the addition of the solvent methanol to the double bond provided compound **PO27** as major product (Scheme 17) [32]. It was not studied whether the use of other solvents can suppress this addition reaction. The allyl-substituted  $\beta$ -ketoenamide **KE7** was converted under the standard conditions into condensation product **PO28**, but in this case a second compound, **PO29** bearing a shifted double bond, was isolated as main product [32].

A few pyrimidine *N*-oxides with special substituents are depicted in Scheme 18. They are generated from the enantiopure  $\beta$ -ketoenamide **KE43** [30], the biphenyl derivative **KE45** [41] and the aryl-substituted  $\beta$ -ketoenamides **KE78** and **KE80** [46]. In all cases, the corresponding heterocycles **PO30–33** were isolated in moderate to good yields.

## Typical subsequent reactions of pyrimidine *N*-oxides

The *N*-oxide moiety of pyrimidine *N*-oxides can easily be reduced by various methods, as shown by the reduction of **PO4** with hydrogen/palladium to give pyrimidine **PM5** (Scheme 19) [30]. Although compounds such as **PM5** are also directly available by condensation with ammonium salts (see above), the detour via pyrimidine *N*-oxides may have advantages in certain cases due to the milder reaction conditions of the condensation step. However, a more important transformation of pyrimidine *N*-oxides **PO** represents the Boekelheide rearrangement [55] to afford 4-acetoxymethyl-substituted pyrimidines and some typical examples of this side-chain functionalization are depicted in Scheme 19. Treatment of pyrimidine *N*-oxide **PO13** with acetic anhydride at 90 °C furnished the expected pyrimidine derivative **PM61** in 69% yield [32] showing that this transformation involves an internal redox reaction. However, the mechanism of this rearrangement is still under discussion [56,57] and side-products such as **PM62** having a 4-ethyl group (3% yield) and other compounds evidence the participation of



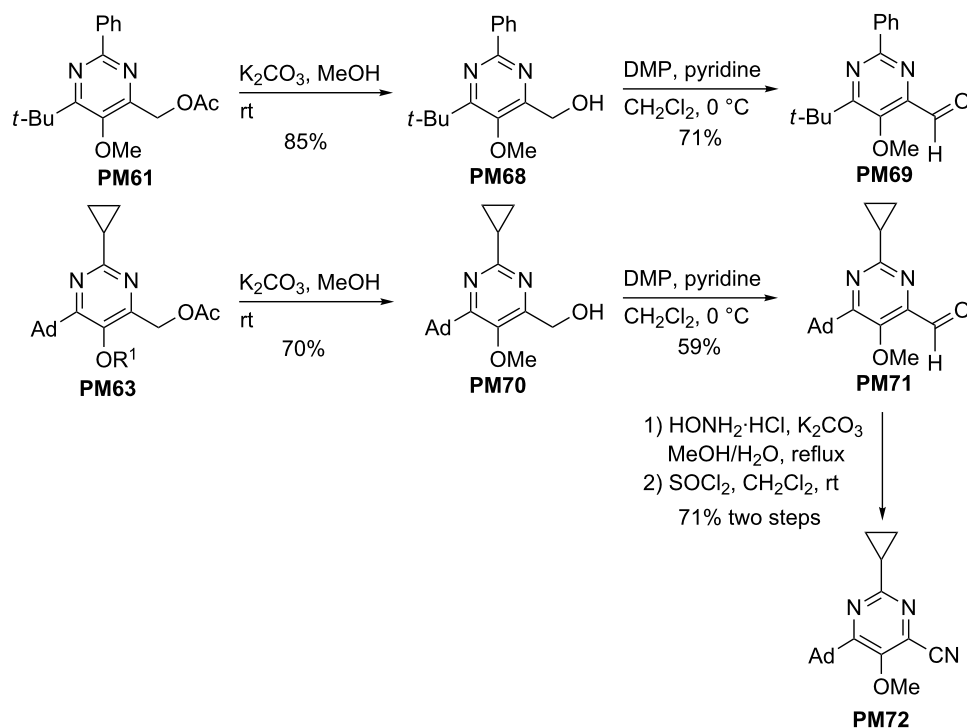
**Scheme 19:** Reduction of **PO4** to **PM5** and Boekelheide rearrangements of **PO13**, **PO14**, **PO4** and **PO30** to 4-acetoxymethyl-substituted pyrimidine derivatives; Ad = 1-adamantyl.

radicals [30]. After the efficient conversion of pyrimidine *N*-oxide **PO14** into pyrimidine **PM63** no products of this type were isolated. The regioselectivity is another important feature of the Boekelheide rearrangement if alkyl groups are present at C-2 or C-4 next to the *N*-oxide moiety. The pyrimidine *N*-oxide **PO4** offers a benzyl substituent and a methyl group whereas **PO30** bears two methyl groups. In both cases, 1:1 mixtures of the two possible rearranged products, **PM64** and **PM65** [50] or **PM66** and **PM67** [30] were isolated, respectively.

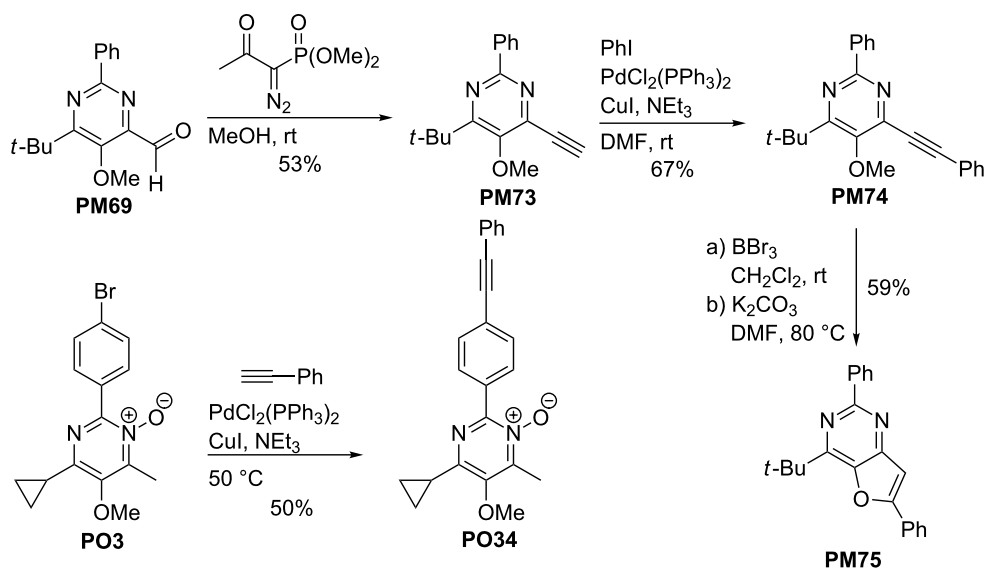
4-Acetoxymethyl-substituted pyrimidine derivatives offer many options for the introduction of new substituents. For example the removal of the acetyl group by treatment with potassium carbonate in methanol and oxidation with Dess–Martin periodinane (DMP) converted **PM61** and **PM63** into aldehydes **PM69** and **PM71** in reasonable overall yields (Scheme 20) [30]. This

pathway via the pyrimidine *N*-oxides represents a good alternative to the direct oxidation of the 4-methyl group by selenium dioxide (see Scheme 11). The subsequent transformation of the aldehyde **PM71** to the oxime followed by dehydration afforded nitrile **PM72** in good yield [30]. The latter should be a suitable precursor for three-component reactions with alkoxyallenes and carboxylic acids to furnish new  $\beta$ -ketoenamides **KE** bearing a 6-adamantyl-2-cyclopropyl-5-methoxypyrimidin-4-yl substituent. This again stresses the flexibility and versatility of our approach to complex heterocycles.

The aldehyde **PM69** was further converted into the terminal alkyne **PM73** by employing the Bestmann–Ohira protocol (Scheme 21). After its Sonogashira reaction with iodobenzene to the intermediate disubstituted alkyne **PM74** this compound was converted into furopyrimidine derivative **PM75** [30].



**Scheme 20:** Deprotection of 4-acetoxymethyl-substituted pyrimidine derivatives **PM61** and **PM63**, oxidations to formyl-substituted pyrimidines **PM69** and **PM71** and synthesis of nitrile **PM72** (DMP = Dess–Martin periodinane).



**Scheme 21:** Synthesis of pyrimidyl-substituted alkyne **PM74** and conversion into furopyrimidine **PM75** and Sonogashira reaction of **PO3** with ethynylbenzene to pyrimidine *N*-oxide **PO34**.

Finally, the bromoaryl group in **PO3** was engaged in a coupling with ethynylbenzene to give **PO34**. This latter reaction proves that the *N*-oxide moiety is compatible with palladium/

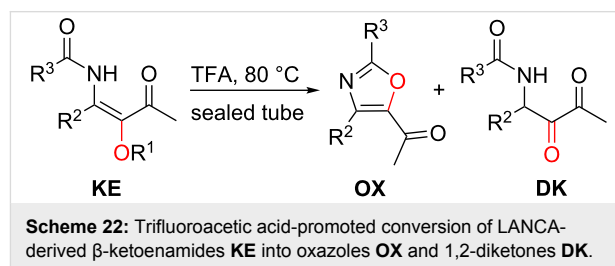
copper-catalyzed reactions [30]. The conversion of the 5-alkoxy substituent into a nonafloxy group (as shown above with the pyrimidine derivatives, see Scheme 13) was not examined so

far, however, it should be possible. Hence, the pyrimidine *N*-oxides may also be used in other palladium-catalyzed processes in order to introduce new substituents at C-5 of the heterocycles.

## Synthesis of oxazole derivatives

By brief heating with trifluoroacetic acid  $\beta$ -ketoenamides **KE** with acid-labile alkoxy substituents OR<sup>1</sup> underwent an unexpected formation of 5-acetyl-substituted oxazole derivatives **OX** (Scheme 22) [42,45]. This useful transformation proceeds with benzyloxy-, *p*-methoxybenzyl-, 2-tetrahydropyranyl- and 2-(trimethylsilyl)ethoxy-substituted  $\beta$ -ketoenamides **KE** as precursors and - mainly depending on the size of substituent R<sup>2</sup> - oxazoles **OX** and/or the simple hydrolysis products 1,2-diketones **DK** were isolated in moderate to excellent yields (Table 6). With substituents R<sup>2</sup> of moderate bulkiness the oxazoles **OX** are formed exclusively (Table 6, entries 1, 3–6, 17, and 20–23), whereas for the two compounds **KE57** and **KE58** (R<sup>2</sup> = R<sup>3</sup> = cyclopropyl) the corresponding oxazoles **OX6** and **OX7** were isolated as highly predominating products (Table 6, entries 7 and 8), but traces of the corresponding 1,2-diketones **DK2** and **DK3** were detected in the crude product. The reactions of  $\beta$ -ketoenamides **KE60**, **KE61** and **KE68**

(R<sup>2</sup> = *tert*-butyl or adamantanyl, R<sup>3</sup> = methyl, trifluoromethyl or cyclopropyl) provided mixtures of oxazoles **OX7**, **OX8** and **OX10**, respectively, and of 1,2-diketones **DK4**, **DK5** and **DK11** (Table 6, entries 9, 10, and 16). For examples with very bulky substituents R<sup>2</sup> and R<sup>3</sup> the exclusive formation of the 1,2-diketones **DK1** and **DK6–10** was observed (Table 6, entries 2, and 11–15). Trifluoroacetic acid treatment of  $\beta$ -ketoenamides **KE70** and **KE71** not only furnished **DK12** and **DK13** in moderate yield, but also dimeric products whose structure has still to be established [43].



The method could also be extended to aryl-substituted  $\beta$ -ketoenamide **KE79** that delivered oxazole derivative **OX16** in 59% yield (Scheme 23) [45]. A subsequent reduction of the car-

**Table 6:** Preparation of oxazoles **OX1–15** and 1,2-diketones **DK1–13** through trifluoroacetic acid-promoted reaction of  $\beta$ -ketoenamides **KE**.<sup>a</sup>

entry	KE	R <sup>1</sup>	R <sup>2</sup>	R <sup>3</sup>	OX	yield	DK	yield	ref.
1	<b>KE48</b>	Bn	<i>n</i> -Non	Ph	<b>OX1</b>	51%	–	–	[45]
2	<b>KE51</b>	Bn	<i>t</i> -Bu	2-Th	–	–	<b>DK1</b>	83%	[45]
3	<b>KE52</b>	Bn	Ph	CF <sub>3</sub>	<b>OX2</b>	74%	–	–	[45]
4	<b>KE53</b>	Bn	Ph	Ph	<b>OX3</b>	48%	–	–	[45]
5	<b>KE54</b>	Bn	Ph	2-Py	<b>OX4</b>	64%	–	–	[45]
6	<b>KE56</b>	PMB	Ph	CF <sub>3</sub>	<b>OX5</b>	53%	–	–	[45]
7	<b>KE57</b>	2-THP	cPr	cPr	<b>OX6</b>	51%	<b>DK2</b>	<1%	[45]
8	<b>KE58</b>	TMSE	cPr	cPr	<b>OX7</b>	67%	<b>DK3</b>	<1%	[45]
9	<b>KE60</b>	TMSE	<i>t</i> -Bu	Me	<b>OX8</b>	24%	<b>DK4</b>	29%	[45]
10	<b>KE61</b>	TMSE	<i>t</i> -Bu	CF <sub>3</sub>	<b>OX9</b>	61%	<b>DK5</b>	31%	[45]
11	<b>KE62</b>	TMSE	<i>t</i> -Bu	CH=CH <sub>2</sub>	–	–	<b>DK6</b>	73%	[43]
12	<b>KE63</b>	TMSE	<i>t</i> -Bu	CH=CH-Me	–	–	<b>DK7</b>	80%	[43]
13	<b>KE64</b>	TMSE	<i>t</i> -Bu	CH=CH-Ph	–	–	<b>DK8</b>	60%	[43]
14	<b>KE65</b>	TMSE	<i>t</i> -Bu	CH=CH-C <sub>6</sub> H <sub>4</sub> -NO <sub>2</sub>	–	–	<b>DK9</b>	55%	[43]
15	<b>KE66</b>	TMSE	<i>t</i> -Bu	CH=CH-2-Fu	–	–	<b>DK10</b>	70%	[43]
16	<b>KE68</b>	TMSE	Ad	cPr	<b>OX10</b>	12%	<b>DK11</b>	65%	[45]
17	<b>KE69</b>	TMSE	Ph	CF <sub>3</sub>	<b>OX11</b>	98%	–	–	[45]
18	<b>KE70</b>	TMSE	Ph	CH=CH-Me	–	–	<b>DK12</b>	30% <sup>b</sup>	[43]
19	<b>KE71</b>	TMSE	Ph	CH=CH-Ph	–	–	<b>DK13</b>	33% <sup>b</sup>	[43]
20	<b>KE72</b>	TMSE	Ph	C≡CH	<b>OX12</b>	57%	–	–	[45]
21	<b>KE74</b>	TMSE	Ph	2-Py	<b>OX13</b>	99%	–	–	[45]
22	<b>KE75</b>	TMSE	Ph	2-Th	<b>OX14</b>	68%	–	–	[45]
23	<b>KE76</b>	TMSE	Ph	Ac	<b>OX15</b>	39%	–	–	[45]

<sup>a</sup>Abbreviations: Ad = 1-adamantyl, Py = pyridyl, Fu = furyl, Th = thienyl, Ac = acetyl; all alkenyl substituents are *E*-configured. <sup>b</sup>In addition, ca. 30% of a dimeric compound were isolated.

bonyl group followed by iodine-induced elimination gave the 5-styryl-substituted oxazole **OX17**. This sequence demonstrates the potential of the C-5 functionalized oxazoles to be used for further transformations (see below).

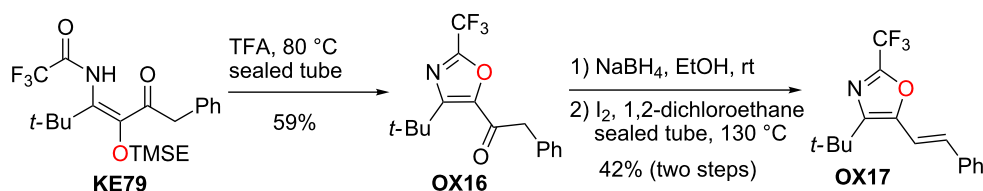
The examples collected in Table 6 show a dichotomy of oxazole and 1,2-diketone formation that is not fully understood so far. As mentioned above, the presence of bulky substituents  $R^2$  (and  $R^3$ ) seems to be a prerequisite of the 1,2-diketone formation, however, for the series with  $R^2$  = phenyl the observed product distributions are not easy to explain (Table 6, entries 18–23). Nevertheless, a plausible mechanism is presented in Scheme 24 showing the analogy to the Gabriel–Robinson oxazole synthesis [58]. For  $\beta$ -ketoenamides **KE** with  $OR^1$  groups that are not easily cleaved by acids the cyclization to pyridin-4-ol derivatives **PY** occurs without touching of the alkoxy group. If this group is reacting with trifluoroacetic acid the *E*-configured enol *E*-**EN** is generated first and its prototropy directly delivers the isolated 1,2-diketones **DK**. Experiments with labelled oxygen showed that the oxazole oxygen originates from the alkoxy group and not from the amide moiety [45]. The oxazole formation therefore requires a configurational switch from enol *E*-**EN** to *Z*-**EN**. Very likely, this step is acid-catalyzed as the subsequent cyclization to form the five-membered intermediate **L** and

the final water elimination to oxazole **OX**. The formation of *Z*-**EN** is possibly disfavored by bulky groups  $R^2$  due to repulsion with the acetyl group. The cyclization step leading to **L** may also be hampered if  $R^3$  is too bulky. In these cases, no sufficient concentrations of *Z*-**EN** or of **L** are formed and hence the 1,2-diketones **DK** are obtained as the products. It should also be mentioned that isolated 1,2-diketones **DK** do not undergo cyclizations to **OX** even after extended treatment with trifluoroacetic acid.

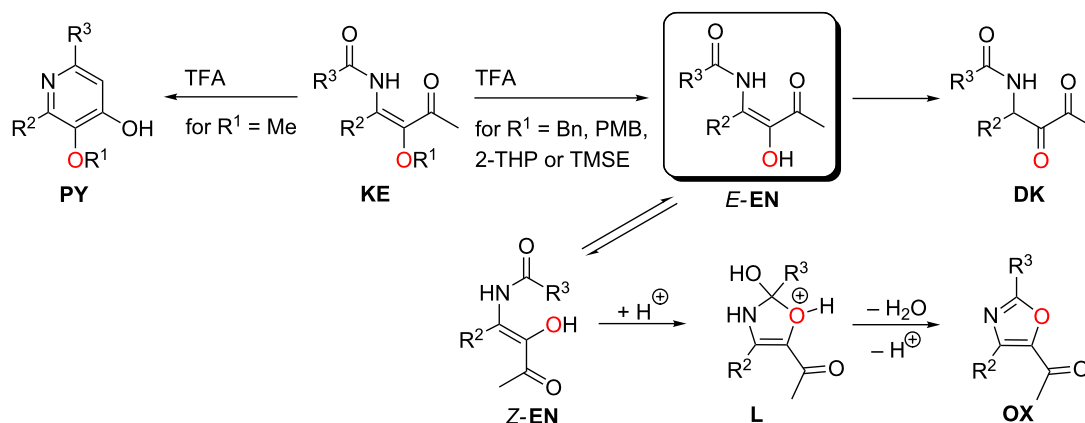
As an alternative to the strongly acidic conditions, palladium-catalyzed hydrogenolysis of the benzyloxy-substituted derivatives is possible, thus avoiding the condensation to oxazoles. Scheme 25 shows the conversion of **KE52** into 1,2-diketone **DK14** (compare entry 3 of Table 6). Longer reaction times lead to a subsequent reduction of the internal carbonyl group as shown by the conversion of **KE54** into the two diastereomeric  $\alpha$ -hydroxy- $\beta$ -amino ketones **9** [45]. Due to the moderate mass balance of this transformation we cannot exclude that the second carbonyl group was also partially reduced.

### Subsequent reactions of oxazole derivatives

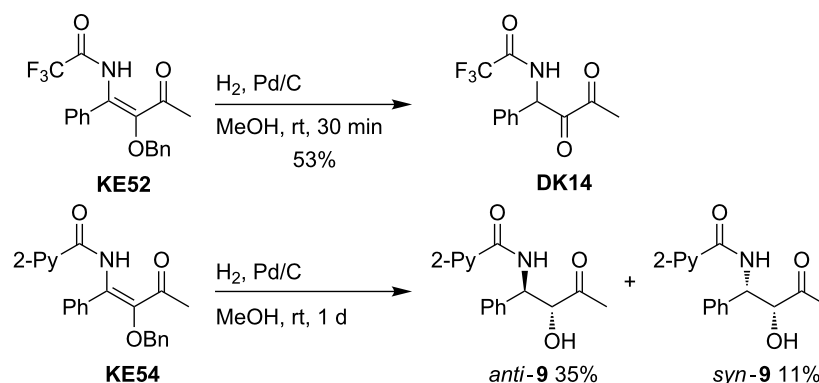
As already shown in Scheme 23, the carbonyl group at C-5 of oxazole derivatives **OX** offers possibilities for subsequent reac-



**Scheme 23:** Conversion of  $\beta$ -ketoenamide **KE79** into oxazole **OX16** and transformation into 5-styryl-substituted oxazole **OX17**.



**Scheme 24:** Mechanisms of the formation of 1,2-diketones **DK** and of acetyl-substituted oxazole derivatives **OX**.



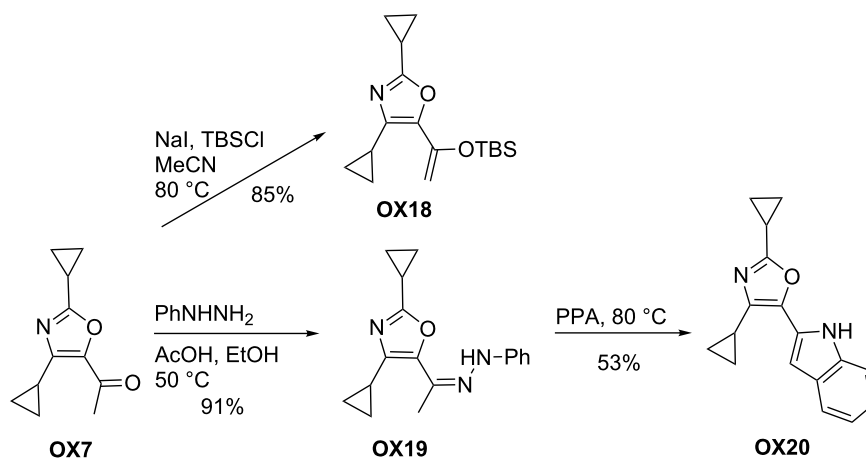
**Scheme 25:** Hydrogenolyses of benzyloxy-substituted  $\beta$ -ketoenamides **KE52** and **KE54** to 1,2-diketone **DK14** and to diastereomeric  $\alpha$ -hydroxy- $\beta$ -amino ketones **9**.

tions to other functionalized oxazoles. Typical examples are depicted in Scheme 26 and Scheme 27 employing 2,4-dicyclopropyl-substituted oxazole **OX7** as the starting material. The efficient conversion of the acetyl group into the corresponding silyl enol ether moiety delivered **OX18** that may be used for further transformations. Alternatively, **OX7** and phenyl hydrazine afforded the corresponding hydrazone **OX19** in excellent yield that was further treated with polyphosphoric acid to undergo a Fischer indole reaction to 5-indolyl-substituted oxazole **OX20**.

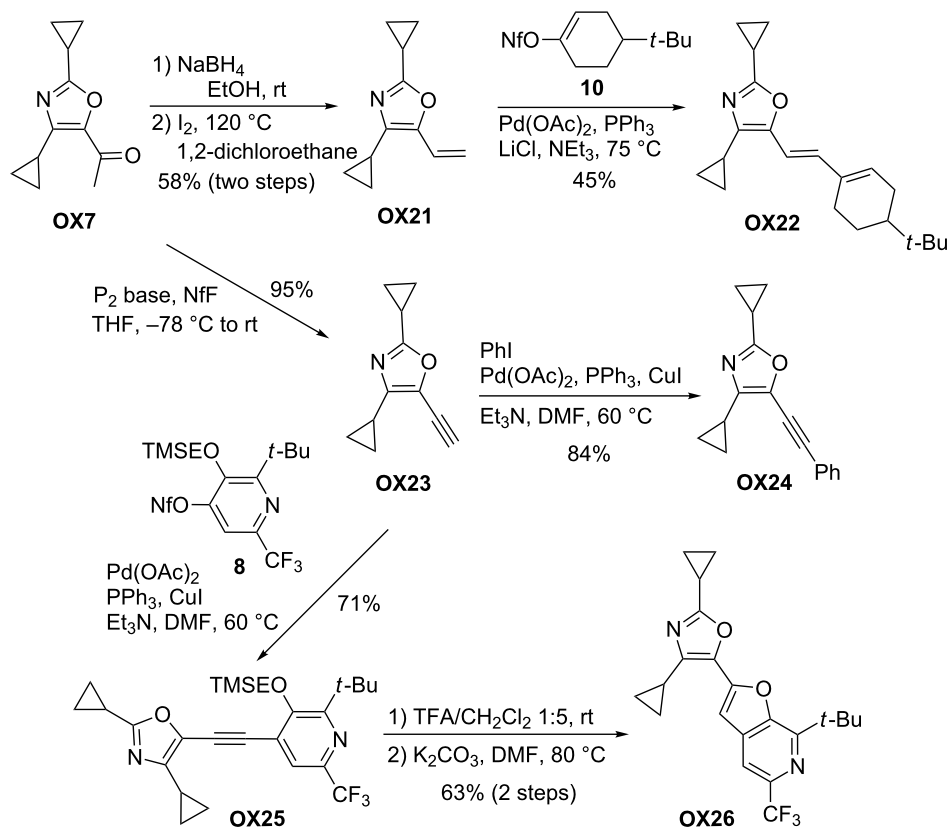
To demonstrate the versatility of the route to new oxazole derivatives, typical palladium-catalyzed processes are compiled in Scheme 27. First, the acetyl moiety was converted into a vinyl or an ethynyl substituent. The reduction of **OX7** followed by elimination to **OX21** proceeded smoothly and as subsequent transformation a Heck reaction with alkenyl nonaflate **10** was performed delivering **OX22**. The conversion of **OX7** to alkyne

**OX23** applied the protocol of Lyapkalo et al. [59] using Schwesinger's base [60] as crucial reagent. First, the corresponding nonaflate is generated from **OX7** that immediately underwent elimination to the alkyne. Ethynyl-substituted oxazole **OX23** was isolated in excellent yield and subsequently employed in Sonogashira couplings. Iodobenzene afforded compound **OX24** in high yield and ( $\beta$ -ketoamide-based) pyridinyl nonaflate **8** gave **OX25**. The removal of the TMSE group by acid treatment and subsequent cyclization furnished the furopyridyl-substituted oxazole derivative **OX26** in good overall yield [45]. The examples shown in Scheme 27 and Scheme 28 demonstrate the manifold options to synthesize complex heterocyclic systems by the building block system derived from  $\beta$ -ketoenamides **KE**.

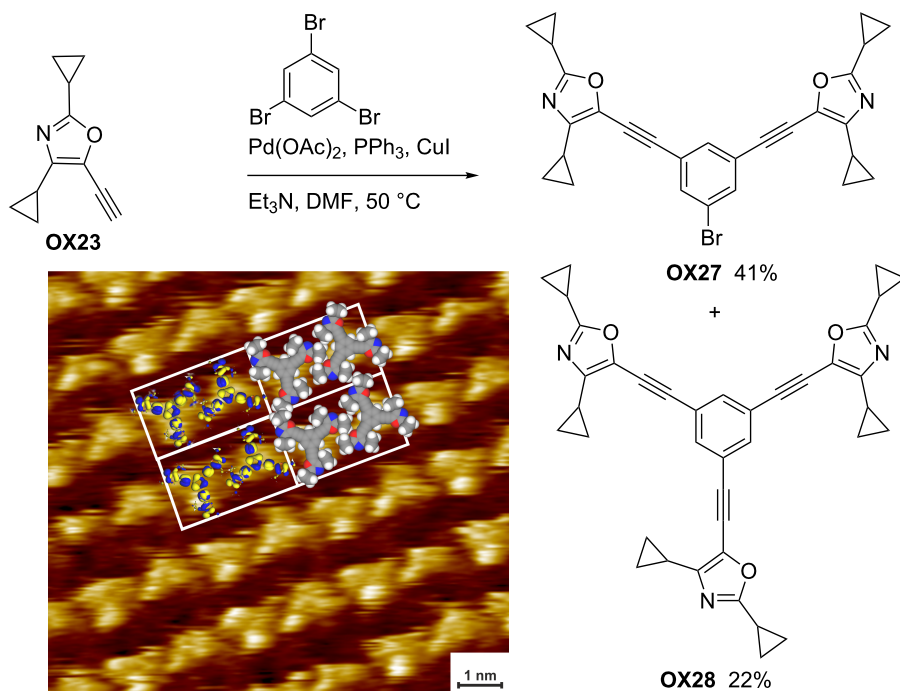
Finally, the synthesis of star-shaped compound **OX28** is presented. A threefold Sonogashira reaction of 1,3,5-tribromobenzene with ethynyl-substituted **OX23** gave the desired



**Scheme 26:** Conversions of 2,4-dicyclopropyl-substituted oxazole **OX7** into oxazole derivatives **OX18–20** (PPA = polyphosphoric acid).



**Scheme 27:** Syntheses of vinyl and ethynyl-substituted oxazole derivatives **OX21** and **OX23** and their palladium-catalyzed reactions to **OX22** and **OX24–26** (Schwesinger  $\text{P}_2$  base).

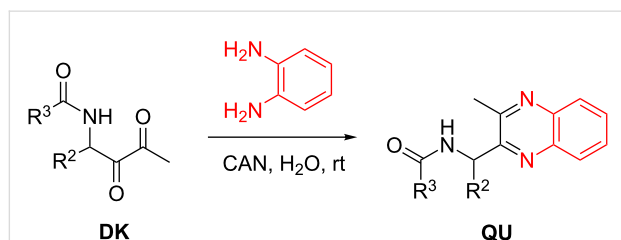


**Scheme 28:** Synthesis of  $\text{C}_3$ -symmetric oxazole derivative **OX28** and the STM current image of its 1-phenyloctane solution on highly oriented pyrolytic graphite (HOPG).

**OX28** in 22% yield; the major product (41%) of this experiment was the double-coupling product **OX27** and the mono-coupling product (not shown) was isolated in 5% yield [45]. A solution of the  $C_3$ -symmetric compound **OX28** in 1-phenyloc-tane was investigated by scanning tunneling microscopy (STM) to reveal its ability to form self-assembled monolayers at the interface with highly oriented pyrolytic graphite (HOPG). The STM current image inserted in Scheme 28 shows bright areas that indicate the positions of the  $\pi$ -systems, whereas the dark areas indicate the cyclopropyl groups.

## Synthesis of quinoxalines

The acylamido-substituted 1,2-diketones **DK** obtained by hydrolysis of several  $\beta$ -ketoenamides **KE** also offer possibilities of further synthetic applications. The reduction to  $\alpha$ -hydroxy- $\beta$ -amino ketones such as compound **9** has been already mentioned (see Scheme 25), but the vicinal carbonyl groups may also be employed for condensation reactions leading to heterocycles, for instance the Radziszewski reaction to imidazoles [61,62]. As an example, the condensation of 1,2-diketones **DK** with *o*-phenylenediamine to quinoxalines **QU** [63] employing cerium ammonium nitrate [64] as catalyst was investigated (Scheme 29). This transformation proceeded smoothly at room temperature in water as solvent and provided the expected acylamido-substituted quinoxalines **QU1–7** in moderate to good yields (Table 7) [43,45].



**Scheme 29:** Condensation of 1,2-diketones **DK** with *o*-phenylenediamine to quinoxalines **QU1–7** (CAN = cerium ammonium nitrate).

**Table 7:** Preparation of quinoxalines **QU1–7** by condensation of 1,2-diketones **DK** with *o*-phenylenediamine.<sup>a</sup>

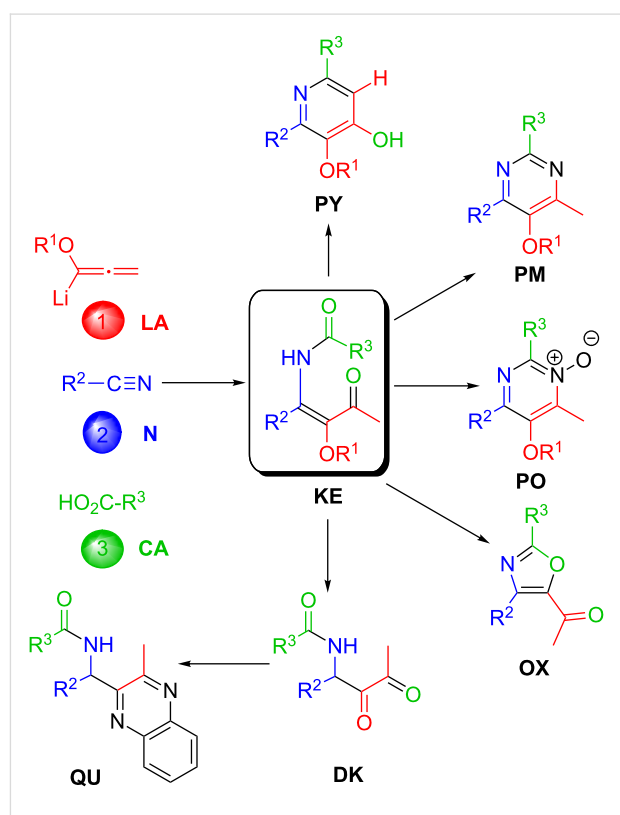
entry	DK	R <sup>2</sup>	R <sup>3</sup>	QU	yield	ref.
1	<b>DK1</b>	<i>t</i> -Bu	2-Th	<b>QU1</b>	41%	[45]
2	<b>DK6</b>	<i>t</i> -Bu	CH=CH <sub>2</sub>	<b>QU2</b>	51%	[43]
3	<b>DK7</b>	<i>t</i> -Bu	CH=CH-Me	<b>QU3</b>	58%	[43]
4	<b>DK8</b>	<i>t</i> -Bu	CH=CH-Ph	<b>QU4</b>	53%	[43]
5	<b>DK10</b>	<i>t</i> -Bu	CH=CH-2-Fu	<b>QU5</b>	55%	[43]
6	<b>DK11</b>	Ad	cPr	<b>QU6</b>	30%	[45]
7	<b>DK13</b>	Ph	CH=CH-Ph	<b>QU7</b>	42%	[43]

<sup>a</sup>Abbreviation: Ad = 1-adamantyl, Fu = furyl, Th = thienyl; all alkenyl substituents are *E*-configured.

## Conclusion

Lithiated alkoxyallenes **LA**, nitriles **N** and carboxylic acids **CA** undergo a three-component reaction (LANCA reaction) that affords  $\beta$ -ketoenamides **KE** in good to very good yields (Scheme 30). The reaction proceeds through a unique mechanism being driven by the high energy level of the allenes. The eighty examples of  $\beta$ -ketoenamides **KE** collected in this review impressively demonstrate the broad scope of this three-component reaction that is compatible with all kinds of substituents R<sup>2</sup> and R<sup>3</sup> and several functional groups within these substituents. Enantiopure components efficiently lead to products with stereogenic centers. Dinitriles or dicarboxylic acids provide the expected bis- $\beta$ -ketoenamides in moderate yield.

The prepared  $\beta$ -ketoenamides **KE** are excellent precursors for the synthesis of specifically substituted heterocycles (Scheme 30). The intramolecular aldol-type condensations leading to a manifold of pyridine derivatives **PY** was already subject of a review article [23]. In this report, we demonstrate that the  $\beta$ -ketoenamides **KE** are also excellent precursors for the synthesis of a variety of pyrimidines **PM**, pyrimidine *N*-oxides **PO**, 4-acetyl-substituted oxazoles **OX** and – via 1,2-diketones **DK** – of quinoxalines **QU**. The substitution pattern of all com-



**Scheme 30:** The LANCA three-component reaction leading to  $\beta$ -ketoenamides **KE** and the structure of functionalized pyridines **PY**, pyrimidines **PM**, pyrimidine *N*-oxides **PO**, oxazoles **OX**, 1,2-diketones **DK** and quinoxalines **QU** derived thereof.

pounds allows specific subsequent reactions, for instance, by substitution of the alkoxy groups with a nonafloxy group all kinds of palladium-catalyzed coupling reactions. Specific oxidation reactions also lead to a variety of new heterocyclic compounds. All the examples collected here show the potential of this approach to highly functionalized heterocycles, furnishing compounds with a very high degree of structural diversity that should be of interest in drug synthesis or material science. The versatility of alkoxyallenes [11–20,65,66] as easily available C<sub>3</sub> building blocks is key for this prosperousness.

## Acknowledgements

We thank the group members mentioned in the references who contributed to this project and gratefully acknowledge the German Academic Exchange Service, the Alexander von Humboldt Foundation and the German Research Foundation (DFG) for support of this work, in part through the collaborative research center SFB 765.

## ORCID® IDs

Hans-Ulrich Reissig - <https://orcid.org/0000-0002-1912-9635>

## References

- Dömling, A.; Ugi, I. *Angew. Chem., Int. Ed.* **2000**, *39*, 3168–3210. doi:10.1002/1521-3773(20000915)39:18<3168::aid-anie3168>3.0.co;2-u  
*Angew. Chem.* **2000**, *112*, 3300–3344. doi:10.1002/1521-3757(20000915)112:18<3300::AID-ANGE3300>3.0.CO;2-Z
- Zhu, J.; Bienaymé, H., Eds. *Multicomponent Reactions*; Wiley-VCH: Weinheim, Germany, 2005.
- Dömling, A. *Chem. Rev.* **2006**, *106*, 17–89. doi:10.1021/cr0505728
- D'Souza, D. M.; Müller, T. J. J. *Chem. Soc. Rev.* **2007**, *36*, 1095–1108. doi:10.1039/b608235c
- Brauch, S.; van Berkel, S. S.; Westermann, B. *Chem. Soc. Rev.* **2013**, *42*, 4948–4962. doi:10.1039/c3cs35505e
- Multicomponent Reactions. In *Science of Synthesis*; Müller, T. J. J., Ed.; Thieme Verlag: Stuttgart, Germany, 2014.
- Zhu, J.; Wang, Q.; Wang, M.-X., Eds. *Multicomponent Reactions in Organic Synthesis*; Wiley-VCH Verlag GmbH: Weinheim, Germany, 2014. doi:10.1002/9783527678174
- Levi, L.; Müller, T. J. J. *Chem. Soc. Rev.* **2016**, *45*, 2825–2846. doi:10.1039/c5cs00805k
- Eckert, H. *Molecules* **2017**, *22*, No. 349. doi:10.3390/molecules22030349
- Reissig, H.-U.; Zimmer, R. Allenes in Multicomponent Synthesis of Heterocycles. *Multicomponent Reactions in Organic Synthesis*; Wiley-VCH Verlag GmbH: Weinheim, Germany, 2014; pp 301–332. doi:10.1002/9783527678174.ch11
- Reissig, H.-U.; Hormuth, S.; Schade, W.; Okala Amombo, M.; Watanabe, T.; Pulz, R.; Hausherr, A.; Zimmer, R. *J. Heterocycl. Chem.* **2000**, *37*, 597–606. doi:10.1002/jhet.5570370316
- Reissig, H.-U.; Schade, W.; Okala Amombo, G. M.; Pulz, R.; Hausherr, A. *Pure Appl. Chem.* **2002**, *74*, 175–180. doi:10.1351/pac200274010175
- Zimmer, R.; Reissig, H.-U. In *Donor-Substituted Allenes in Modern Allene Chemistry*; Krause, N.; Hashmi, A. S. K., Eds.; Wiley-VCH: Weinheim, Germany, 2004; pp 425–492.
- Tius, M. A.; Zimmer, R.; Reissig, H.-U. 1-Methoxyallenylithium. *Encyclopedia of Reagents for Organic Synthesis*; John Wiley & Sons, Ltd: Chichester, United Kingdom, 2006. doi:10.1002/047084289x.rm077.pub2
- Brasholz, M.; Reissig, H.-U.; Zimmer, R. *Acc. Chem. Res.* **2009**, *42*, 45–56. doi:10.1021/ar800011h
- Pfrenkle, F.; Reissig, H.-U. *Chem. Soc. Rev.* **2010**, *39*, 549–557. doi:10.1039/b914356d
- Lechel, T.; Reissig, H.-U. *Pure Appl. Chem.* **2010**, *82*, 1835–1844. doi:10.1351/pac-con-09-09-06
- Bouché, L.; Reissig, H.-U. *Pure Appl. Chem.* **2012**, *84*, 23–36. doi:10.1351/pac-con-11-09-20
- Zimmer, R.; Reissig, H.-U. *Chem. Soc. Rev.* **2014**, *43*, 2888–2903. doi:10.1039/c3cs60429b
- Reissig, H.-U.; Zimmer, R. *Synthesis* **2017**, *49*, 3291–3302. doi:10.1055/s-0036-1588846
- Flögel, O.; Dash, J.; Brüdgam, I.; Hartl, H.; Reissig, H.-U. *Chem. – Eur. J.* **2004**, *10*, 4283–4290. doi:10.1002/chem.200400322
- Lechel, T.; Dash, J.; Hommes, P.; Lentz, D.; Reissig, H.-U. *J. Org. Chem.* **2010**, *75*, 726–732. doi:10.1021/jo9022183
- Lechel, T.; Reissig, H.-U. Synthesis and Reactivity of Pyridin-4-ols Based on the Three-Component Reaction of Alkoxyallenes, Nitriles and Carboxylic Acids. In *Targets in Heterocyclic Systems - Chemistry and Properties*; Attanasi, O. A.; Merino, P.; Spinelli, D., Eds.; Italian Society of Chemistry: Rome, Italy, 2016; Vol. 20, pp 1–32. doi:10.17374/targets.2017.20.1
- Hoff, S.; Brandsma, L.; Arens, J. F. *Recl. Trav. Chim. Pays-Bas* **1968**, *87*, 916–924. doi:10.1002/recl.19680870807
- Weiberth, F. J.; Hall, S. S. *J. Org. Chem.* **1985**, *50*, 5308–5314. doi:10.1021/jo00225a061
- Seghers, S.; Heugebaert, T. S. A.; Moens, M.; Sonck, J.; Thybaut, J. W.; Stevens, C. V. *ChemSusChem* **2018**, *11*, 2248–2254. doi:10.1002/cssc.201800760
- Lechel, T.; Dash, J.; Eidamshaus, C.; Brüdgam, I.; Lentz, D.; Reissig, H.-U. *Org. Biomol. Chem.* **2010**, *8*, 3007–3014. doi:10.1039/b925468d
- Unger, L.; Accorsi, M.; Eidamshaus, C.; Reich, D.; Zimmer, R.; Reissig, H.-U. *Synthesis* **2018**, *50*, 4071–4080. doi:10.1055/s-0037-1609576
- Lechel, T.; Möhl, S.; Reissig, H.-U. *Synlett* **2009**, 1059–1062. doi:10.1055/s-0028-1088220
- Zimmer, R.; Reissig, H.-U. unpublished results.
- Bera, M. K.; Reissig, H.-U. *Synthesis* **2010**, 2129–2138. doi:10.1055/s-0029-1218787
- Zimmer, R.; Lechel, T.; Rancan, G.; Bera, M. K.; Reissig, H.-U. *Synlett* **2010**, 1793–1796. doi:10.1055/s-0030-1258088
- Lechel, T.; Reissig, H.-U. *Eur. J. Org. Chem.* **2010**, 2555–2564. doi:10.1002/ejoc.201000056
- Bera, M. K.; Hommes, P.; Reissig, H.-U. *Chem. – Eur. J.* **2011**, *17*, 11838–11843. doi:10.1002/chem.201101739
- Eidamshaus, C.; Reissig, H.-U. *Adv. Synth. Catal.* **2009**, *351*, 1162–1166. doi:10.1002/adsc.200800789
- Eidamshaus, C.; Kumar, R.; Bera, M. K.; Reissig, H.-U. *Beilstein J. Org. Chem.* **2011**, *7*, 962–975. doi:10.3762/bjoc.7.108
- Eidamshaus, C.; Reissig, H.-U. *Tetrahedron: Asymmetry* **2011**, *22*, 1644–1652. doi:10.1016/j.tetasy.2011.08.017

38. Zimmer, R.; Orschel, B.; Scherer, S.; Reissig, H.-U. *Synthesis* **2002**, 1553–1563. doi:10.1055/s-2002-33328
39. Hausherr, A.; Zimmer, R.; Reissig, H.-U. *Synthesis* **2019**, *51*, 486–499. doi:10.1055/s-0037-1609942
40. Dash, J.; Lechel, T.; Reissig, H.-U. *Org. Lett.* **2007**, *9*, 5541–5544. doi:10.1021/ol702468s
41. Bera, M. K.; Domínguez, M.; Hommes, P.; Reissig, H.-U. *Beilstein J. Org. Chem.* **2014**, *10*, 394–404. doi:10.3762/bjoc.10.37
42. Lechel, T.; Lentz, D.; Reissig, H.-U. *Chem. – Eur. J.* **2009**, *15*, 5432–5435. doi:10.1002/chem.200900386
43. Kumar, R. Master Thesis, Freie Universität Berlin 2010.
44. Hausherr, A.; Reissig, H.-U. *Synthesis* **2018**, *50*, 2546–2554. doi:10.1055/s-0037-1609688
45. Lechel, T.; Gerhard, M.; Trawny, D.; Brusilowskij, B.; Schefzig, L.; Zimmer, R.; Rabe, J. P.; Lentz, D.; Schalley, C. A.; Reissig, H.-U. *Chem. – Eur. J.* **2011**, *17*, 7480–7491. doi:10.1002/chem.201100382
46. Linder, I. Master Thesis, Freie Universität Berlin 2011.
47. Brown, D. J. Pyrimidines and their Benzo Derivatives. In *Comprehensive Heterocyclic Chemistry*; Katritzky, A. R.; Rees, C. W., Eds.; Pergamon Press: Oxford, 1984; Vol. 3, pp 57–155. doi:10.1016/b978-008096519-2.00035-7
48. Angerer, S. Product Class 12: Pyrimidines. In *Science of Synthesis*; Yamamoto, Y., Ed.; Category 2, Hetarenes and Related Ring Systems, Vol. 16; Thieme: Stuttgart, 2004; pp 379–572. doi:10.1055/sos-sd-016-00463
49. Lambert, C. *Heterocycles* **2006**, *68*, 561–603. doi:10.3987/rev-05-604
50. Bera, M. K.; Reissig, H.-U. unpublished results.
51. Van Leusen, D.; Van Leusen, A. M. Synthetic Uses of Tosylmethyl Isocyanide (TosMIC). *Organic Reactions*; John Wiley & Sons, Inc.: Hoboken, NJ, U.S.A., 2001; pp 417–666. doi:10.1002/0471264180.or057.03
52. Högermeier, J.; Reissig, H.-U. *Adv. Synth. Catal.* **2009**, *351*, 2747–2763. doi:10.1002/adsc.200900566
53. Cimen, A. *Bachelor Thesis*, Freie Universität Berlin, 2011.
54. Dreßler, A. *Bachelor Thesis*, Freie Universität Berlin, 2014.
55. Boekelheide, V.; Linn, W. J. *J. Am. Chem. Soc.* **1954**, *76*, 1286–1291. doi:10.1021/ja01634a026
56. Massaro, A.; Mordini, A.; Mingardi, A.; Klein, J.; Andreotti, D. *Eur. J. Org. Chem.* **2011**, 271–279. doi:10.1002/ejoc.201000936
57. Further Reactions of N-Oxides. In *Introductory Heterocyclic Chemistry*; Jacobi, P. A., Ed.; Wiley-VCH: Weinheim, Germany, 2019; pp 61–69.
58. Wasserman, H. H.; Vinick, F. J. *J. Org. Chem.* **1973**, *38*, 2407–2408. doi:10.1021/jo00953a028
59. Lyapkalo, I. M.; Vogel, M. A. K. *Angew. Chem., Int. Ed.* **2006**, *45*, 4019–4023. doi:10.1002/anie.200504594  
*Angew. Chem.* **2006**, *118*, 4124–4127. doi:10.1002/ange.200504594
60. Schwesinger, R.; Schlemper, H. *Angew. Chem., Int. Ed. Engl.* **1987**, *26*, 1167–1169. doi:10.1002/anie.198711671  
*Angew. Chem.* **1987**, *99*, 1212–1214. doi:10.1002/ange.19870991134
61. *Comprehensive Organic Name Reactions and Reagents*; Wang, Z., Ed.; John Wiley & Sons: New Jersey, 2009; Vol. 3, p 2293.
62. Breslin, H. J.; Miskowski, T. A.; Rafferty, B. M.; Coutinho, S. V.; Palmer, J. M.; Wallace, N. H.; Schneider, C. R.; Kimball, E. S.; Zhang, S.-P.; Li, J.; Colburn, R. W.; Stone, D. J.; Martinez, R. P.; He, W. *J. Med. Chem.* **2004**, *47*, 5009–5020. doi:10.1021/jm030548r
63. Brown, D. J. Quinoxalines, Supplement II. In *The Chemistry of Heterocyclic Compounds*; Taylor, E. C.; Wipf, P., Eds.; John Wiley & Sons: New Jersey, 2004; Vol. 61.
64. More, S. V.; Sastry, M. N. V.; Yao, C.-F. *Green Chem.* **2006**, *8*, 91–95. doi:10.1039/b510677j
65. Nedolya, N. A.; Tarasova, O. A.; Volostnykh, O. G.; Albanov, A. L.; Klyba, L. V.; Trofimov, B. A. *Synthesis* **2011**, 2192–2204. doi:10.1055/s-0030-1260084
66. Tius, M. A. *Chem. Soc. Rev.* **2014**, *43*, 2979–3002. doi:10.1039/c3cs60333d

## License and Terms

This is an Open Access article under the terms of the Creative Commons Attribution License (<http://creativecommons.org/licenses/by/4.0>). Please note that the reuse, redistribution and reproduction in particular requires that the authors and source are credited.

The license is subject to the *Beilstein Journal of Organic Chemistry* terms and conditions: (<https://www.beilstein-journals.org/bjoc>)

The definitive version of this article is the electronic one which can be found at:  
<doi:10.3762/bjoc.15.61>



# Synthesis of a novel category of pseudo-peptides using an Ugi three-component reaction of levulinic acid as bifunctional substrate, amines, and amino acid-based isocyanides

Maryam Khalesi<sup>1</sup>, Azim Ziyaei Halimehjani<sup>\*1</sup> and Jürgen Martens<sup>\*2</sup>

## Full Research Paper

Open Access

### Address:

<sup>1</sup>Faculty of Chemistry, Kharazmi University, P.O. Box 15719-14911, 49 Mofateh Street, Tehran, Iran and <sup>2</sup>Institut für Chemie (IfC), Carl von Ossietzky Universität Oldenburg, P.O. Box 2503, 26111 Oldenburg, Germany

### Email:

Azim Ziyaei Halimehjani\* - ziyaei@khu.ac.ir; Jürgen Martens\* - juergen.martens@uni-oldenburg.de

\* Corresponding author

### Keywords:

amino acid-based isocyanides; levulinic acid; multicomponent; pseudo-peptides; Ugi reaction

*Beilstein J. Org. Chem.* **2019**, *15*, 852–857.

doi:10.3762/bjoc.15.82

Received: 22 February 2019

Accepted: 29 March 2019

Published: 04 April 2019

This article is part of the thematic issue "Multicomponent reactions III".

Guest Editor: T. J. J. Müller

© 2019 Khalesi et al.; licensee Beilstein-Institut.

License and terms: see end of document.

## Abstract

The synthesis of a novel category of pseudo-peptides via intramolecular Ugi reaction of levulinic acid (4-oxopentanoic acid), aromatic and aliphatic amines, and amino acid-based isocyanides is reported. Levulinic acid was applied as a bifunctional substrate containing both carbonyl and acid moieties suitable for the Ugi reaction. This article provides a facile and convenient one-pot procedure for the synthesis of peptide-like heterocyclic molecules containing 2-pyrrolidone ( $\gamma$ -lactam), amide and ester functional groups with good to excellent yields.

## Introduction

The multistep synthesis of complex molecules normally requires a large number of repetitive synthetic operations, such as extraction, separation, chromatography and other purification steps. These disadvantages encouraged chemists to synthesize complex molecules using multicomponent reactions (MCRs). MCRs transform three or more starting materials into a single product in an atom- and step-economical way in diversity- and target-oriented syntheses in modern organic synthesis. In addition, MCRs are characterized by high yields, time efficiency, low waste production, and reduced energy consumption [1-9]. So, the design of novel MCRs with facile and green pro-

cesses has fascinated considerable attention in the fields of drug discovery, organic synthesis of natural products, and materials sciences [10].

Undoubtedly, one of the most prominent and studied MCRs is the Ugi reaction. The Ugi four-component condensation reaction (U-4CC) between an aldehyde, an amine, a carboxylic acid and an isocyanide provides a rapid preparation of  $\alpha$ -aminoacyl amide or pseudo-peptide derivatives. These biologically active peptide-like molecules can be utilized to circumvent some of the problems associated with several natural peptides such as

stability against proteolysis, poor bioavailability, receptor selectivity, and short duration of action [11]. The Ugi reaction allows the introduction of several substituents in its adducts to prepare novel peptidomimetics with potential pharmaceutical applications. Therefore, the development of innovative Ugi reactions is crucial for the synthesis of novel chemical libraries for various purposes [12].

In recent years, one of the modifications for Ugi reactions is the introduction of bifunctional substrates into the Ugi condensation reaction in order to keep the multicomponent sequence as short as possible which makes it less complicated [13–17].

Levulinic acid or 4-oxopentanoic acid, is an organic compound which is classified as a ketoacid. It can be easily prepared in industrial scale and low price by acid catalysis from renewable resources, such as sugars, lignocellulosic biomass and waste materials [18]. It can be used as a bifunctional precursor for the synthesis of pharmaceuticals, plasticizers, and different additives [19]. Furthermore, it is recognized as an excellent starting material for Ugi reactions because it has two functional groups in its structure. By the way, using bifunctional chemicals in Ugi four-component condensation reaction (4CC) converts it to an Ugi three-component condensation reaction (3CC) and this is identified as an Ugi-4-centre-3-component reaction (U-4C-3CR) [20–23]. This reaction proceeds through an intramolecular mechanism which leads to the formation of heterocyclic products as a result of a ring-closure process.

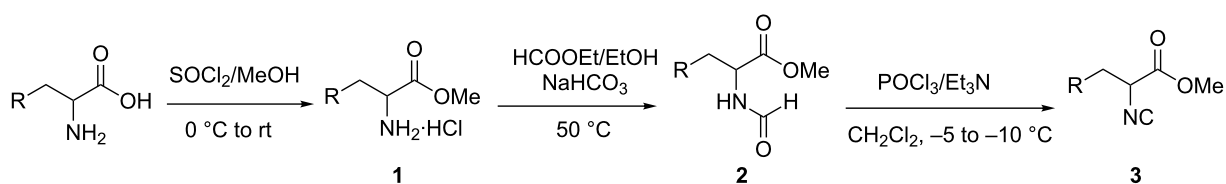
In 1998, Ugi et al. reported the intramolecular Ugi-4C-3CR of ketoacids such as levulinic acid and phthalaldehydic acid with

aliphatic amines and ordinary isocyanides with excellent yields [24]. In 2003, Mironov et al. reported the Ugi reaction of levulinic acid, isocyanides and primary amines in aqueous media with high yields [25]. In addition, Banfi et al. have shown that by using levulinic acid in multicomponent reactions and post-multicomponent reactions, diversities of bicyclic drug-like heterocyclic compounds can be obtained [26].

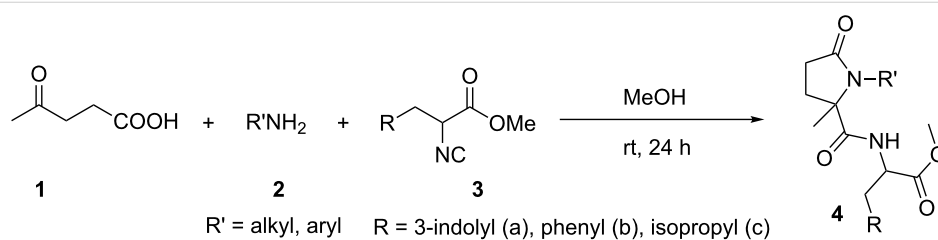
## Results and Discussion

In continuation of our interest on the synthesis of novel pseudo-peptides [27–29] via multicomponent reactions, herein we investigate the Ugi-4C-3CR of levulinic acid, aromatic and aliphatic amines and amino acid-based isocyanides. First of all, racemic  $\alpha$ -amino acids such as DL-tryptophan, DL-phenylalanine and DL-leucine were used as amine source for the synthesis of isocyanide esters **3** through three sequential reactions [30,31]. The first reaction is esterification of the  $\alpha$ -amino acid using thionyl chloride in methanol as reagent and solvent. The second reaction is the formylation of the corresponding amino acid ester salt with ethyl formate in the presence of  $\text{NaHCO}_3$ . Finally, the formamide group was transformed to the corresponding isocyanide **3** using  $\text{POCl}_3$  and triethylamine (Scheme 1).

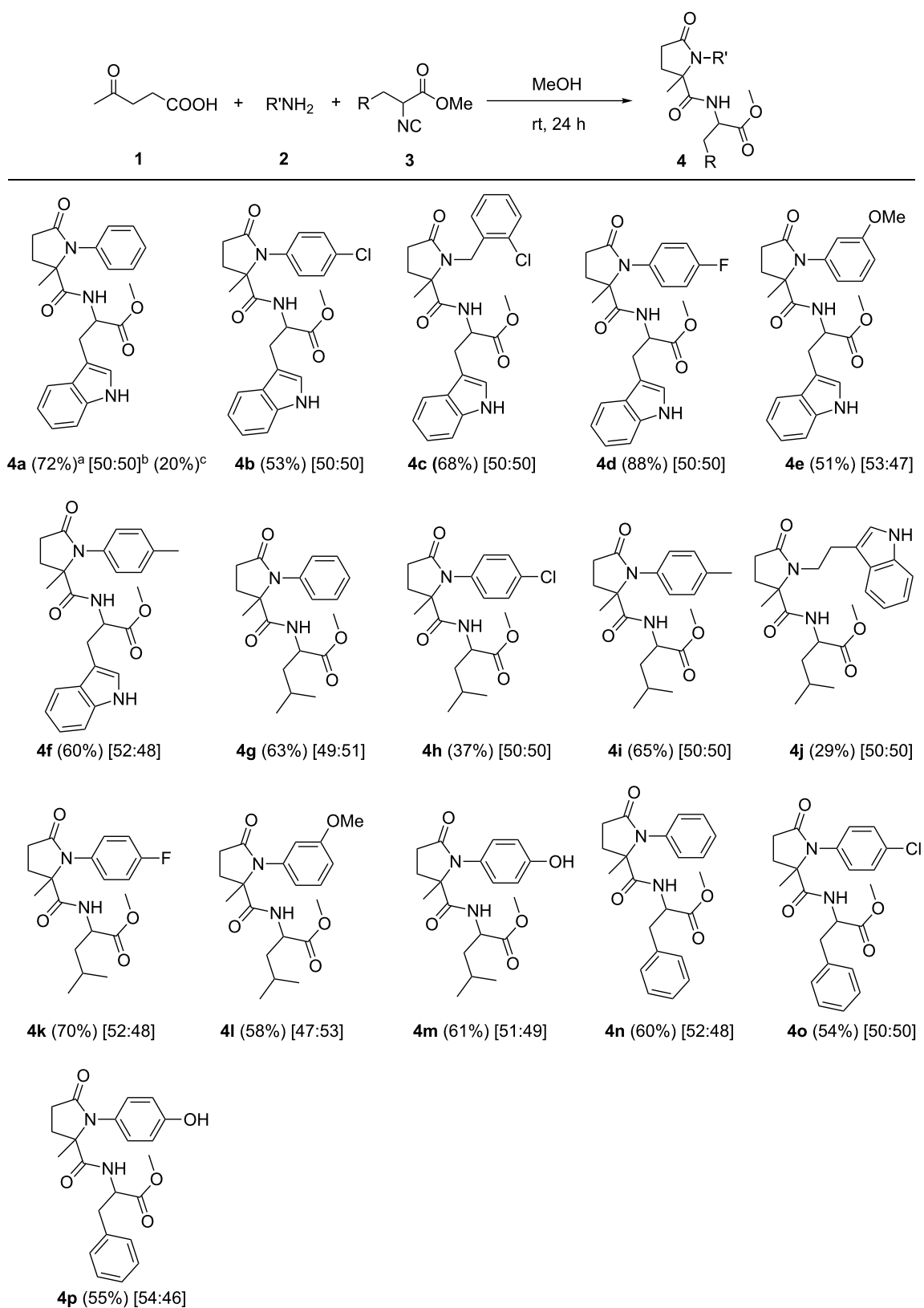
The prepared amino acid-based isocyanides **3** were applied in an Ugi-4C-3CR (Scheme 2). For this purpose, the reactions of one equivalent of bifunctional substrate levulinic acid (**1**), an amine **2** and an isocyanide ester **3** were carried out in methanol as solvent at room temperature to produce the corresponding pseudo-peptides **4**. We observed that under the optimized reaction conditions, good to high yields of products were obtained. The results are summarized in Figure 1. Various aromatic and



**Scheme 1:** Synthesis of amino acid-based isocyanides starting from  $\alpha$ -amino acids.



**Scheme 2:** Synthesis of pseudo-peptides using levulinic acid, isocyanide esters and amines.



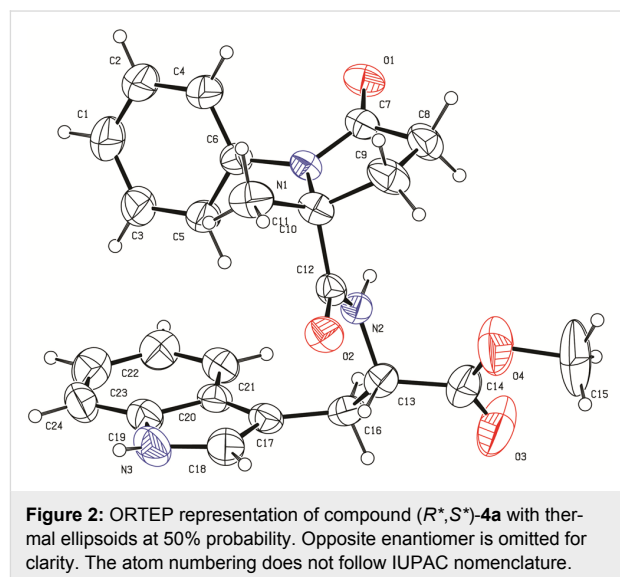
**Figure 1:** Synthesis of functionalized 5-membered lactams using Ugi reaction. <sup>a</sup>Isolated yield for mixture of diastereomers. <sup>b</sup>The ratio of diastereomers was determined by <sup>1</sup>H NMR analysis. <sup>c</sup>Isolated yield of one of the diastereomers as pure stereoisomer after several recrystallization steps.

aliphatic amines were applied in this protocol to give the corresponding pseudo-peptides. For this purpose, aliphatic amines such as *o*-chlorobenzylamine and tryptamine and aromatic amines such as aniline, 4-chloroaniline, 4-aminophenol, *p*-toluidine, 4-fluoroaniline, and *m*-anisidine were applied successfully in this protocol. In addition, all three prepared isocyanides from DL-tryptophane, DL-leucine and DL-phenylalanine worked very well in this reaction to provide the corresponding pseudo-peptides **4** containing  $\gamma$ -lactam, amide and ester functional groups in a single structure.

By starting from DL-amino acids, the corresponding racemic isocyanides were obtained. By using the racemic isocyanides in the Ugi-4C-3CR, a mixture of diastereomers were obtained in approximately 1:1 ratio (see NMR spectra in Supporting Information File 1). Attempts to find a suitable procedure for separation of the diastereomers without losing the yield was not successful. In the case of **4a**, one of the diastereomers [(*R*\*,*S*\*)-**4a**] was obtained as a pure compound in low yield (20%) after several recrystallization steps from MeOH.

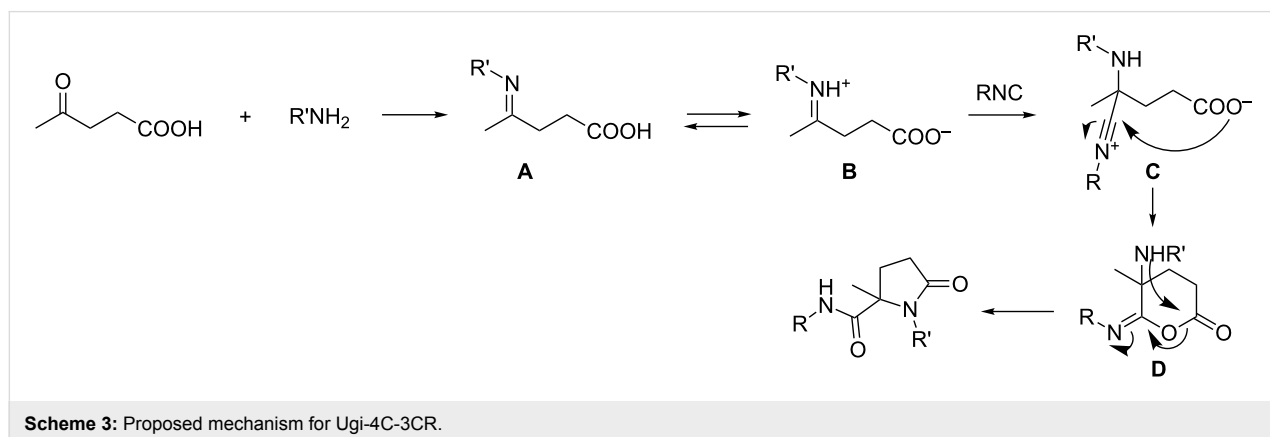
A proposed mechanism for this reaction is depicted in Scheme 3. The primary step in the mechanism is the condensation reaction of the carbonyl group of levulinic acid with an amine component that leads to the formation of an imine intermediate **A**. The formed Schiff base is in equilibrium with its iminium cation **B** as a result of an intramolecular proton exchange with the carboxylic acid moiety which activates the iminium ion for the nucleophilic addition of isocyanide. Consequently, the electrophilic centre of the iminium ion in **B** is subjected to a nucleophilic attack of the isocyanide to furnish the intermediate **C**. Then, a second nucleophilic addition takes place at this nitrilium intermediate **C** with an intramolecular nucleophilic addition of the carboxylate anion. The final step is an acyl transfer from oxygen to nitrogen (Mumm rearrangement) in **D** which completes the Ugi reaction accompanied by formation of the corresponding bis-amides.

The structure of products was confirmed by IR,  $^1\text{H}$  and  $^{13}\text{C}$  NMR, CHN and HRMS analyses and by X-ray crystallography for **4a**. The IR spectra of the derivatives show characteristic absorbance bands at 3200–3500  $\text{cm}^{-1}$  for the N–H bond stretching vibration and at 1640–1750  $\text{cm}^{-1}$  for two carbonyls of the amide groups and one carbonyl of the ester group. The  $^1\text{H}$  NMR spectra of the products show a characteristic peak at 6–7 ppm for the amide hydrogen and a peak as multiplet at 4.40–5.00 ppm for the CH group in the stereogenic center. Carbons of the amide and ester moieties were observed around 170–177 ppm in  $^{13}\text{C}$  NMR spectra. In addition, the structure of compound (*R*\*,*S*\*)-**4a** was confirmed by single crystal X-ray diffraction and an ORTEP representation is shown in Figure 2 (CCDC 1896942); for details of the crystal structure data and refinement of (*R*\*,*S*\*)-**4a** see Supporting Information File 1).



## Conclusion

In conclusion, we have synthesized a novel category of pseudo-peptides containing  $\gamma$ -lactam, amide and ester moieties in a



single structure via Ugi-4-centre-3-component reaction. The main advantage of this paper refers to the application of three amino acid-based isocyanides in the reaction with levulinic acid as a bifunctional substrate and amines which led to the formation of novel peptidomimetics with potential biological activities. In addition, the presence of an ester functional group in the structure of products makes them suitable substrates for further derivatization.

## Supporting Information

### Supporting Information File 1

Experimental procedures, characterization data and copies of  $^1\text{H}$  and  $^{13}\text{C}$  NMR spectra of all compounds.

[<https://www.beilstein-journals.org/bjoc/content/supplementary/1860-5397-15-82-S1.pdf>]

## Acknowledgements

We are thankful to the research council of Kharazmi University for supporting this work. We also thank the central analytic section of the University of Freiburg for retrieving MS data.

## ORCID® IDs

Azim Ziyaei Halimehjeni - <https://orcid.org/0000-0002-0348-8959>

Jürgen Martens - <https://orcid.org/0000-0001-5327-007X>

## References

- Dömling, A. *Chem. Rev.* **2006**, *106*, 17–89. doi:10.1021/cr0505728
- Touré, B. B.; Hall, D. G. *Chem. Rev.* **2009**, *109*, 4439–4486. doi:10.1021/cr800296p
- Sunderhaus, J. D.; Martin, S. F. *Chem. – Eur. J.* **2009**, *15*, 1300–1308. doi:10.1002/chem.200802140
- Wang, H.-Y.; Shi, D.-Q. *ACS Comb. Sci.* **2013**, *15*, 261–266. doi:10.1021/co4000198
- Xiao, Z.; Lei, M.; Hu, L. *Tetrahedron Lett.* **2011**, *52*, 7099–7102. doi:10.1016/j.tetlet.2011.10.099
- Abonia, R.; Castillo, J.; Insuasty, B.; Quiroga, J.; Noguera, M.; Cobo, J. *ACS Comb. Sci.* **2013**, *15*, 2–9. doi:10.1021/co300105t
- Fu, L.-P.; Shi, Q.-Q.; Shi, Y.; Jiang, B.; Tu, S.-J. *ACS Comb. Sci.* **2013**, *15*, 135–140. doi:10.1021/co3001428
- Wang, S.-L.; Cheng, C.; Wu, F.-Y.; Jiang, B.; Shi, F.; Tu, S.-J.; Rajale, T.; Li, G. *Tetrahedron* **2011**, *67*, 4485–4493. doi:10.1016/j.tet.2011.05.002
- Vilches-Herrera, M.; Knepper, I.; de Souza, N.; Villinger, A.; Sosnovskikh, V. Y.; Iaroshenko, V. O. *ACS Comb. Sci.* **2012**, *14*, 434–441. doi:10.1021/co300042v
- Rajesh, S. M.; Bala, B. D.; Perumal, S.; Menéndez, J. C. *Green Chem.* **2011**, *13*, 3248. doi:10.1039/c1gc15794a
- Nielsen, P. E. *Pseudo-peptides in Drug Discovery*; Wiley-VCH: Weinheim, Germany, 2004.
- Ugi, I.; Steinbrückner, C. *Angew. Chem.* **1960**, *72*, 267–268. doi:10.1002/ange.19600720709
- Xu, Z.; Ayaz, M.; Cappelli, A. A.; Hulme, C. *ACS Comb. Sci.* **2012**, *14*, 460–464. doi:10.1021/co300046r
- Gunawan, S.; Hulme, C. *Org. Biomol. Chem.* **2013**, *11*, 6036–6046. doi:10.1039/c3ob40900g
- Rhoden, C. R. B.; Rivera, D. G.; Kreye, O.; Bauer, A. K.; Westermann, B.; Wessjohann, L. A. *J. Comb. Chem.* **2009**, *11*, 1078–1082. doi:10.1021/cc900106u
- Foley, C.; Shaw, A.; Hulme, C. *Org. Lett.* **2016**, *18*, 4904–4907. doi:10.1021/acs.orglett.6b02383
- Koopmanschap, G.; Ruijter, E.; Orru, R. V. *Beilstein J. Org. Chem.* **2014**, *10*, 544–598. doi:10.3762/bjoc.10.50
- Morone, A.; Apte, M.; Pandey, R. A. *Renewable Sustainable Energy Rev.* **2015**, *51*, 548–565. doi:10.1016/j.rser.2015.06.032
- Ghorpade, V.; Hanna, M. *Industrial Applications for Levulinic Acid*. In *Cereals*; Campbell, G. M.; Webb, C.; McKee, S. L., Eds.; Springer: Boston, MA, U.S.A., 1997; pp 49–55. doi:10.1007/978-1-4757-2675-6\_7
- Ugi, I.; Steinbrückner, C. *Chem. Ber.* **1961**, *94*, 2802–2814. doi:10.1002/cber.19610941032
- Obrecht, R.; Toure, S.; Ugi, I. *Heterocycles* **1984**, *21*, 271–277. doi:10.3987/s-1984-01-0271
- Kehagia, K.; Ugi, I. K. *Tetrahedron* **1995**, *51*, 9523–9530. doi:10.1016/0040-4020(95)00542-g
- Nitta, H.; Hatanaka, M.; Ishimaru, T. *J. Chem. Soc., Chem. Commun.* **1987**, 51–52. doi:10.1039/c39870000051
- Hanusch-Kompa, C.; Ugi, I. *Tetrahedron Lett.* **1998**, *39*, 2725–2728. doi:10.1016/s0040-4039(98)00428-6
- Mironov, M. A.; Ivantsova, M. N.; Mokrushin, V. S. *Mol. Diversity* **2003**, *6*, 193–197. doi:10.1023/b:modi.0000006758.61294.57
- Lambruschini, C.; Basso, A.; Moni, L.; Pinna, A.; Riva, R.; Banfi, L. *Eur. J. Org. Chem.* **2018**, 5445–5455. doi:10.1002/ejoc.201801129
- Ziyaei Halimehjeni, A.; Sharifi, M. *Tetrahedron* **2017**, *73*, 5778–5783. doi:10.1016/j.tet.2017.08.028
- Ziyaei Halimehjeni, A.; Ranjbari, M. A.; Pasha Zanussi, H. *RSC Adv.* **2013**, *3*, 22904–22908. doi:10.1039/c3ra44552f
- Khalesi, M.; Halimehjeni, A. Z.; Franz, M.; Schmidtman, M.; Martens, J. *Amino Acids* **2019**, *51*, 263–272. doi:10.1007/s00726-018-2661-0
- Patil, P.; Kurpiewska, K.; Kalinowska-Tłuścik, J.; Dömling, A. *ACS Comb. Sci.* **2017**, *19*, 343–350. doi:10.1021/acscmbsci.7b00033
- Liu, H.; Dömling, A. *J. Org. Chem.* **2009**, *74*, 6895–6898. doi:10.1021/jo900986z

## License and Terms

This is an Open Access article under the terms of the Creative Commons Attribution License (<http://creativecommons.org/licenses/by/4.0>). Please note that the reuse, redistribution and reproduction in particular requires that the authors and source are credited.

The license is subject to the *Beilstein Journal of Organic Chemistry* terms and conditions: (<https://www.beilstein-journals.org/bjoc>)

The definitive version of this article is the electronic one which can be found at:  
[doi:10.3762/bjoc.15.82](https://doi.org/10.3762/bjoc.15.82)



# Synthesis of (macro)heterocycles by consecutive/repetitive isocyanide-based multicomponent reactions

Angélica de Fátima S. Barreto and Carlos Kleber Z. Andrade\*

## Review

Open Access

### Address:

Universidade de Brasília, Instituto de Química, Laboratório de Química Metodológica e Orgânica Sintética (LaQMOS), 70910-970 Brasília-DF, Brazil

### Email:

Carlos Kleber Z. Andrade\* - ckleber@unb.br

\* Corresponding author

### Keywords:

consecutive/repetitive multicomponent reactions; isocyanide; isocyanide-based multicomponent reactions; (macro)heterocycles; Passerini reaction; Ugi reaction

*Beilstein J. Org. Chem.* **2019**, *15*, 906–930.

doi:10.3762/bjoc.15.88

Received: 30 January 2019

Accepted: 27 March 2019

Published: 15 April 2019

This article is part of the thematic issue "Multicomponent reactions III".

Guest Editor: T. J. J. Müller

© 2019 Barreto and Andrade; licensee Beilstein-Institut.

License and terms: see end of document.

## Abstract

Isocyanide-based multicomponent reactions are a versatile tool in the synthesis of heterocycles. This review describes recently developed approaches based on the combination of consecutive or repetitive isocyanide-based multicomponent reactions for the synthesis of structurally diverse heterocycles. These strategies have also allowed the synthesis of a plethora of macroheterocycles in a reduced number of steps.

## Introduction

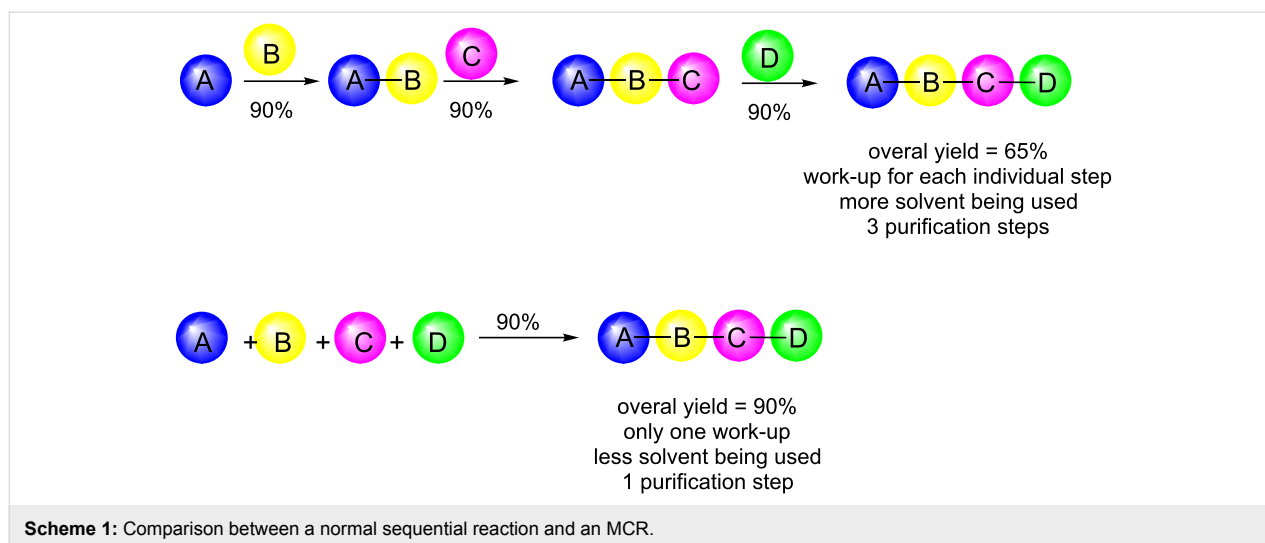
Isocyanide (isonitrile) chemistry was first described by Lieke in 1859 [1] and forms the basis of a large group of reactions in organic chemistry, especially in isocyanide-based multicomponent reactions (IMCRs) [2,3], such as the Passerini and Ugi reactions, which are reactions that have been widely used in the synthesis of peptides, peptidomimetics and heterocycles [4-8]. In this review, we describe synthetic sequences involving repetitive or consecutive IMCRs that have provided molecules with even more structural diversity. By “repetitive” we mean processes in which two or more IMCRs are occurring in the same reaction vessel using polyfunctionalized compounds. In contrast, consecutive processes involve the use of distinct

IMCRs in different stages of a synthetic sequence. This latter strategy requires that the IMCR products have at least one functional group that can be used directly or be manipulated for the subsequent IMCR reaction. These strategies have proved very efficient in the fast obtention of (macro)heterocycles, and the number of examples from the literature has been increasing.

## Review

### Multicomponent reactions (MCRs)

Multicomponent reactions are reactions in which three or more compounds are reacted yielding a product that retains most of the atoms of the starting materials in an atom-economic process



[9–11]. A high level of molecular complexity can be generated in a single step and, by varying the structure of each component, different libraries of molecules can be easily obtained. Compared to a sequential synthesis, this strategy presents several other advantages besides atom economy, such as higher overall yields, easiness of procedure and work-up [12], less solvent being used, fewer residues being produced, fewer purification steps and time-saving, contributing to a more sustainable process (Scheme 1).

The Strecker synthesis of  $\alpha$ -amino cyanides, reported in 1850, is considered to be the first example of an MCR [13]. Since then, several different MCRs have been reported, including the well documented isocyanide-based MCRs (IMCRs). These particular MCRs take advantage of the unique properties of the isocyanide functional group, which is able to undergo both electrophilic and nucleophilic reactions at the carbon atom. The Ugi reaction, firstly reported by Ugi et al. in 1959 [14], involves an amine, a ketone or aldehyde, an isocyanide, and a carboxylic acid to form a dipeptide product. It is undoubtedly one of the most important IMCRs known and has found many applications in synthetic organic chemistry [2,3,9,10]. Among the IMCRs the Ugi reaction has been the most used in the repetitive/consecutive strategy for the synthesis of (macro)heterocycles. The union of different types of MCRs for the synthesis of more complex products has been reviewed [15,16] and this review will focus only on IMCRs.

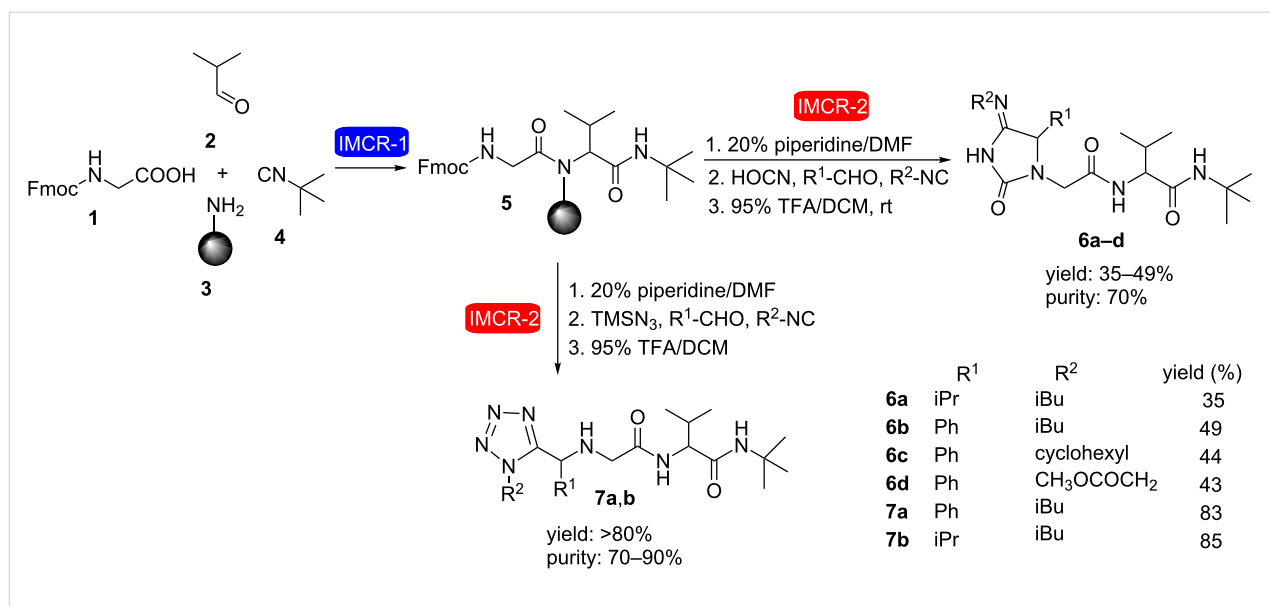
### Consecutive IMCRs

Synthesis of small-ring heterocycles (tetrazoles, ketopiperazines, imidazoles, imidazolines and thiazoles)

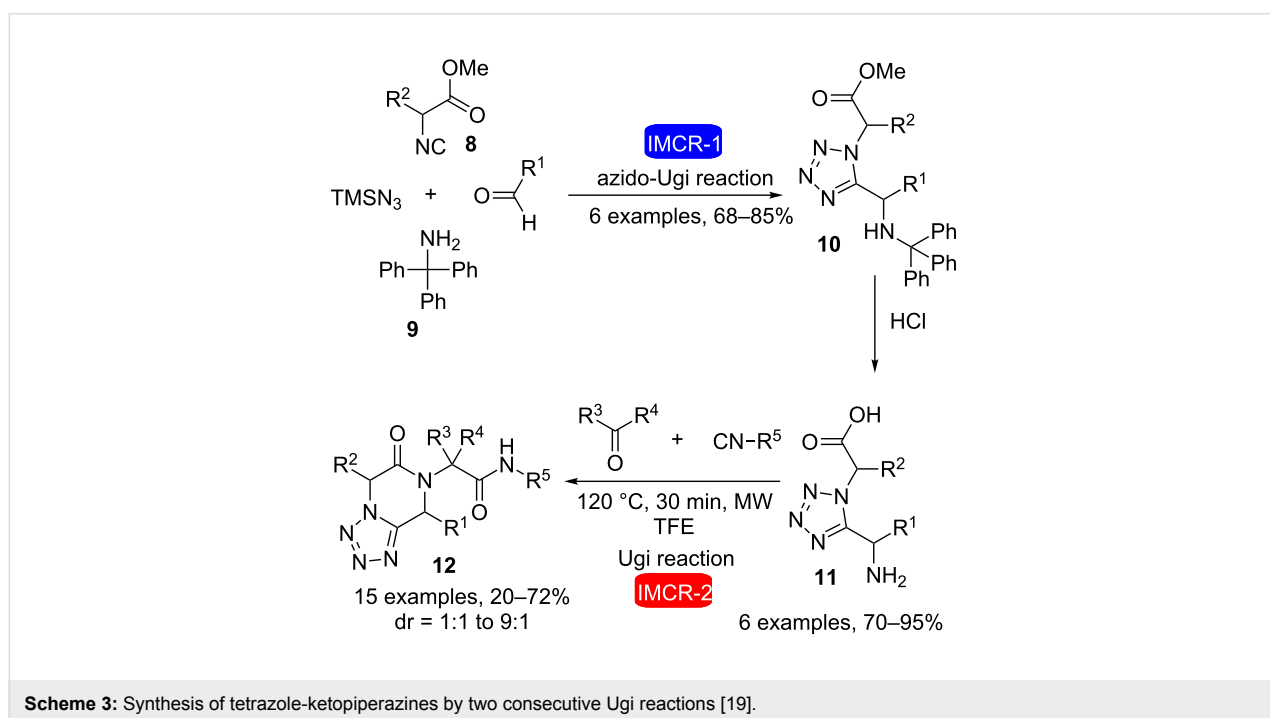
The use of consecutive Ugi reactions in the synthesis of heterocycles was first described in 2001 by Ugi and Constabel [17]

who developed a solid phase strategy to obtain tetrazoles and hydantoinimide derivatives successfully (Scheme 2). In each case, the synthetic sequence began with a classical Ugi reaction between *N*-Fmoc glycine (**1**), isobutyraldehyde (**2**) and *tert*-butyl isocyanide (**4**) in the presence of polystyrene resin **3** as the amine component. After resin removal with piperidine in DMF, a combinatorial strategy of replacing the carboxylic acid component with trimethylsilyl azide (TMSN<sub>3</sub>) (azido-Ugi reaction) or cyanic acid, followed by Fmoc removal (TFA), allowed the formation of the tetrazole (yields >80%) or hydantoinimide nuclei (yields 35–50%), respectively.

Isocynoacetate derivatives **8** are efficient building blocks for the synthesis of structurally complex products and biologically active molecules [18]. After an initial IMCR reaction with their isocyanide moieties, hydrolysis of the ester group present in these compounds allows the obtention of carboxylic acids that can be further used in consecutive IMCRs. Furthermore, optically active isocynoacetates can be easily obtained from natural amino acids. Recently, Dömling et al. [19] used this efficient approach in the synthesis of tetrazole-ketopiperazines (Scheme 3). The strategy involved three steps: first, an Ugi tetrazole reaction between isocynoacetate derivatives **8**, tritylamine (**9**), various aldehydes and TMSN<sub>3</sub>, followed by treatment of the products with aqueous HCl, which cleaved both the trityl group and the methyl ester, to yield amino acids **11** bearing a 1,5-disubstituted tetrazole. The practicality of the Ugi tetrazole reaction (also called Ugi-azide or azido-Ugi reaction) has been recently reviewed [20,21]. These compounds were then used in an intramolecular three-component four-center Ugi reaction using equimolar amounts of each reagent. Neither room-temperature reactions nor reflux conditions led to satisfactory results. However, microwave heating of **11** at 120 °C for 30 min in trifluoroethanol as solvent allowed the obtention of



**Scheme 2:** Synthesis of tetrazoles and hydantoinimide derivatives by consecutive Ugi reactions [17].

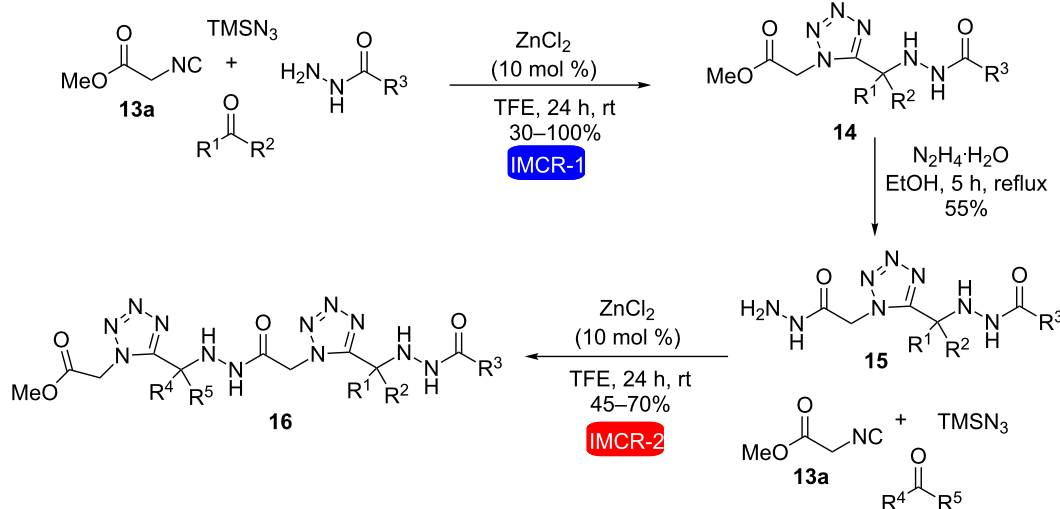


**Scheme 3:** Synthesis of tetrazole-ketopiperazines by two consecutive Ugi reactions [19].

the desired tetrazole-ketopiperazines **12** in yields ranging from 20–72% (1:1 to 9:1 mixture of diastereomers).

Recently, our research group [22] carried out the synthesis of bis(1,5-disubstituted tetrazoles) **14** using two consecutive Ugi reactions (Scheme 4). The synthetic strategy was based on two hydrazino-Ugi-azide reactions and a hydrazinolysis step for the synthesis of acylhydrazino bis(1,5-disubstituted tetrazoles). Methyl isocyanoacetate **13a** was used as an essential compo-

nent in the first hydrazino-Ugi-azide reaction allowing consecutive Ugi reactions to take place. In the first step, **13a**, hydrazides, aldehyde or ketone, trimethylsilyl azide (TMSN<sub>3</sub>) and ZnCl<sub>2</sub> (10 mol %) in trifluoroethanol (TFE) were stirred at room temperature for 24 h to obtain acylhydrazino 1,5-disubstituted tetrazoles **14** in 30–100% yield. Attempts of this reaction without the use of catalyst provided the desired products in low yields. Subsequently, a hydrazinolysis reaction with hydrazine monohydrate led to the corresponding hydrazides **15**, which



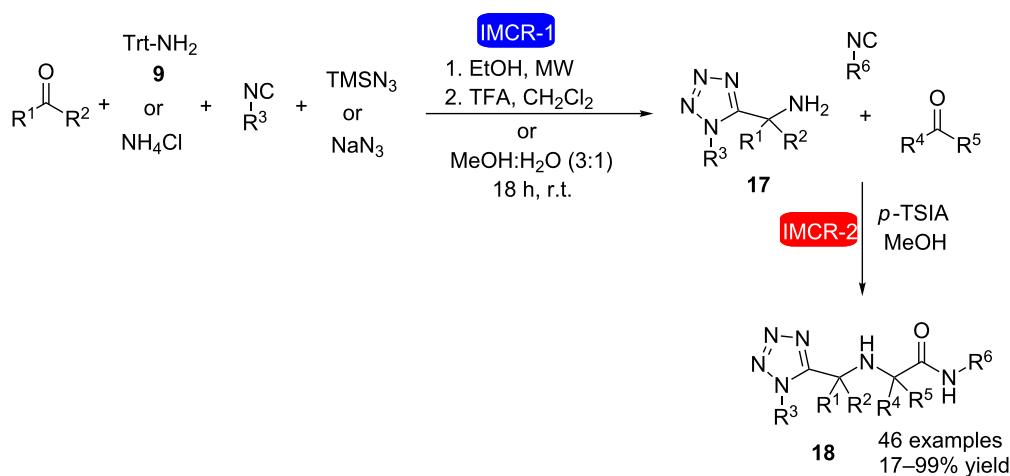
**Scheme 4:** Synthesis of acylhydrazino bis(1,5-disubstituted tetrazoles) through two hydrazine-Ugi-azide reactions and a hydrazinolysis step [22].

were used in a second hydrazine-Ugi-azide reaction with various ketones, to obtain the acylhydrazino bis(1,5-disubstituted tetrazoles) **16** in yields ranging from 45–70%.

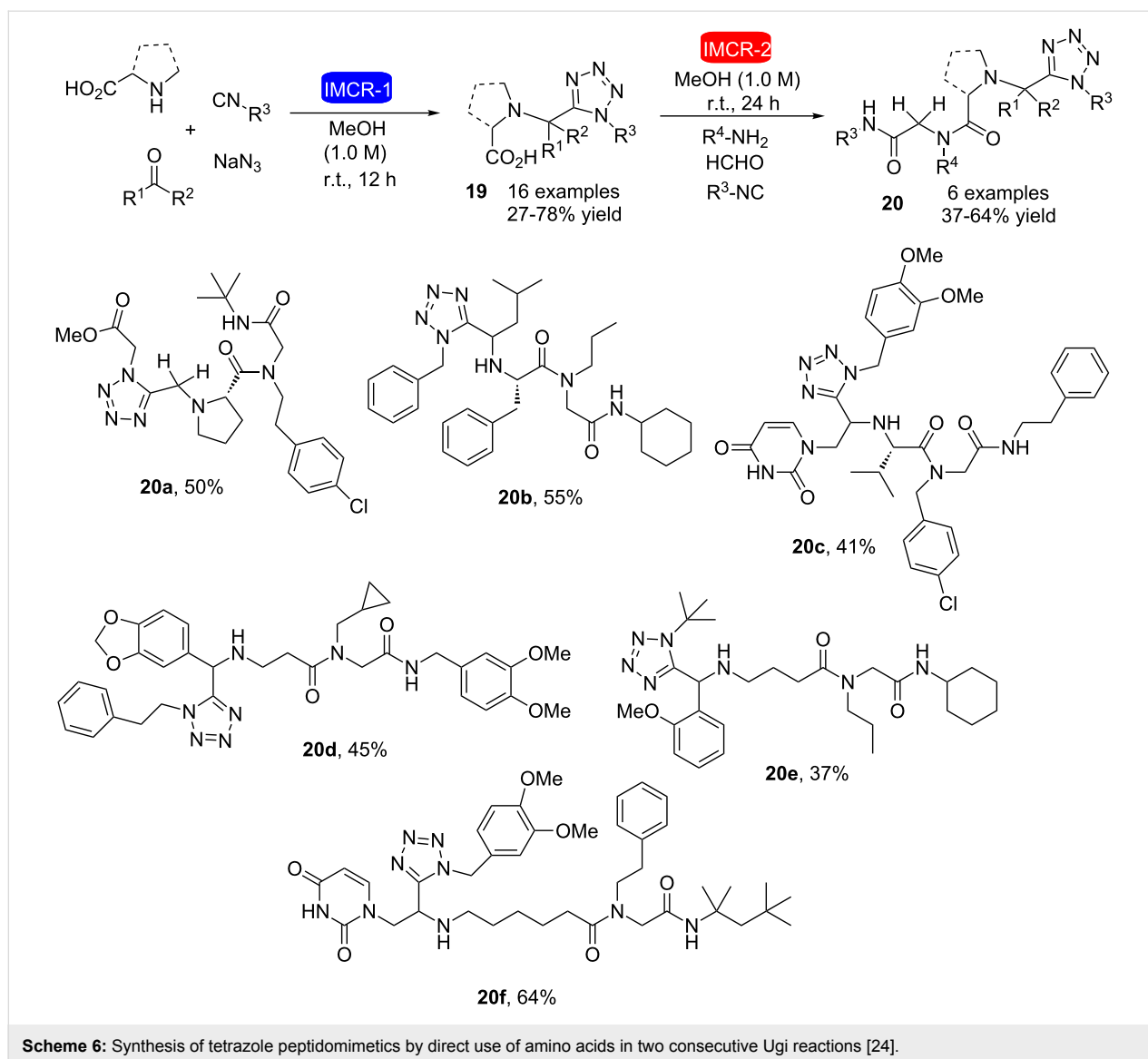
Consecutive Ugi reactions for the synthesis of substituted  $\alpha$ -aminomethyl tetrazoles have also been described (Scheme 5) [23]. The synthetic strategy was based on a four-component Ugi reaction (U-4CR) followed by a three-component Ugi reaction (U-3CR). The first step involved the reaction of ammonium chloride or tritylamine, with oxo components, isocyanide, and sodium azide or TMS azide followed by acid treatment with TFA to obtain  $\alpha$ -aminomethyl tetrazoles **17**. Subsequently, a

new three-component Ugi reaction was performed involving different amino methyl tetrazoles with different oxo components, isocyanides and *p*-toluenesulfonic acid (*p*-TSA) in (semi)stoichiometric amounts to obtain substituted  $\alpha$ -aminomethyltetrazoles **18** in up to 99% yield.

Another recent study carried out the synthesis of tetrazole peptidomimetics by the direct use of unprotected amino acids in two consecutive Ugi-type reactions [24]. Acid-tetrazole compounds **19** were obtained using *C,N*-unprotected amino acids in an Ugi-tetrazole reaction with oxo components, isocyanide, and sodium azide (Scheme 6). The success of the reaction was evi-



**Scheme 5:** Synthesis of substituted  $\alpha$ -aminomethyltetrazoles through two consecutive Ugi reactions (U-4CR and U-3CR) [23].

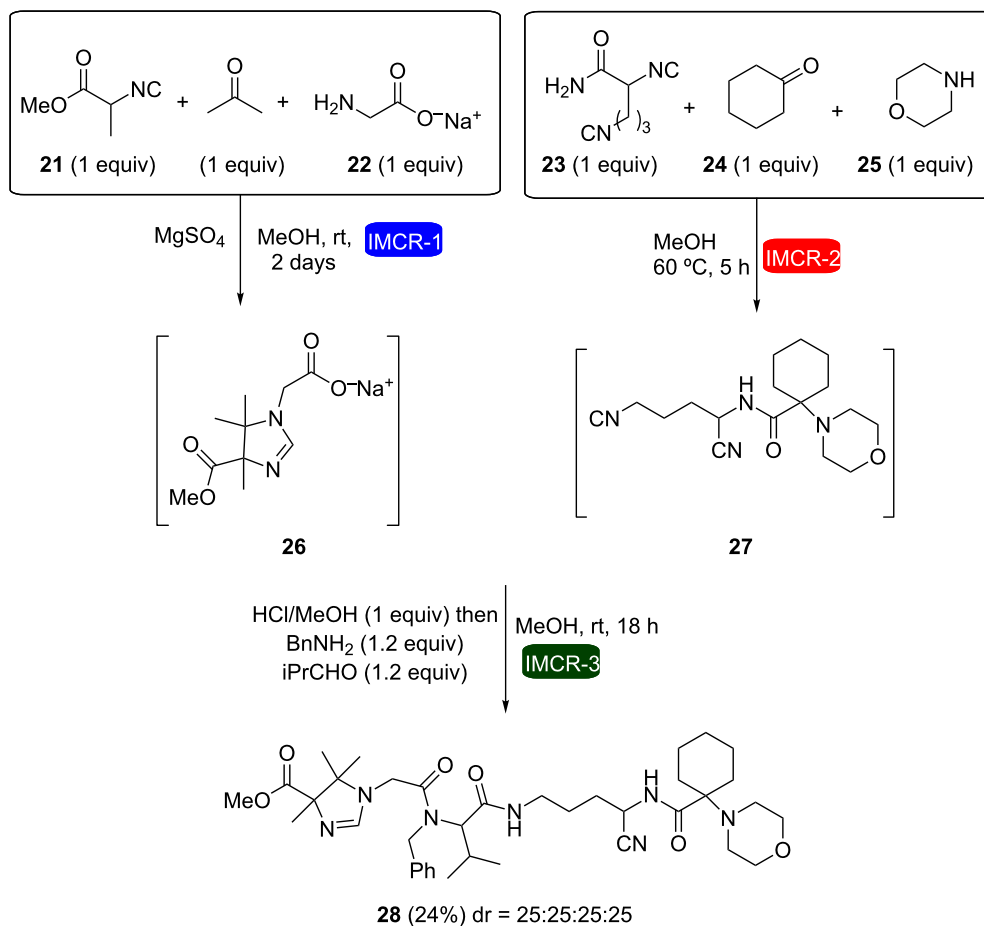


denced by the sole obtention of the Ugi-tetrazole product without any trace of other Ugi-type reaction products. Sequentially, acid **19** was subjected to a second Ugi reaction with oxo components, amines and isocyanides to obtain six tetrazole peptidomimetics (**20a–f**). Highly complex molecules were easily obtained in only two steps (sequential Ugi-tetrazole/Ugi-reaction) without the need for amino acid protection/deprotection reactions.

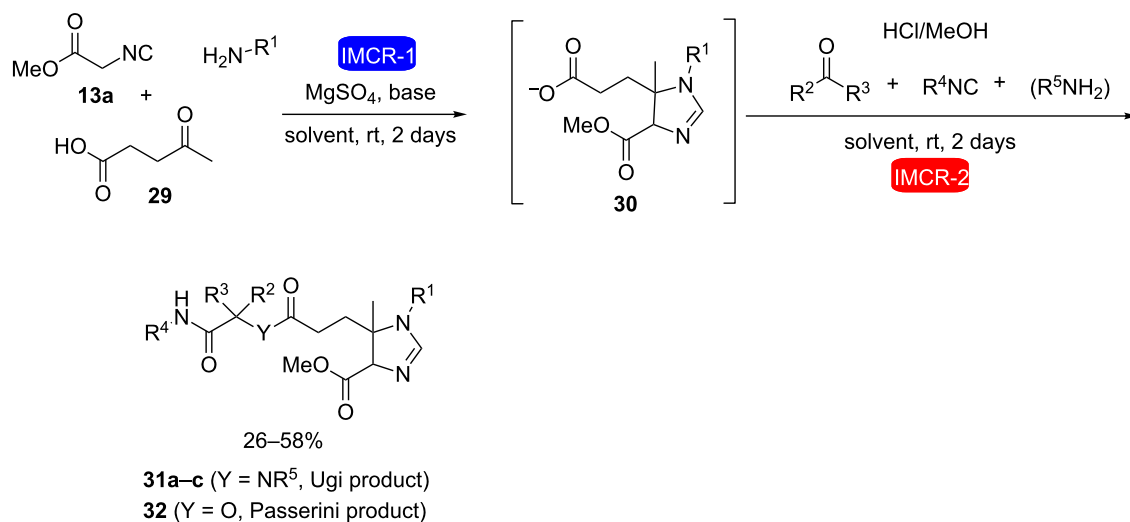
A remarkable result was described by Orru and co-workers who used two consecutive IMCRs in the same reaction pot to obtain the first example of an eight-component reaction (8CR) [25]. This was accomplished after a careful study of functional-group and solvent compatibilities from previous works of the same group and led to the formation of complex molecules possessing many points of diversity. In this strategy, intermedi-

ates **26** and **27** were formed through Ugi-type reactions and then mixed together with benzylamine and isobutyraldehyde to furnish the final product in 24% yield as a mixture of diastereomers (Scheme 7). Other examples of 5- and 6CRs involving Passerini and Ugi reactions such as those represented in Scheme 8 were also reported in the same work.

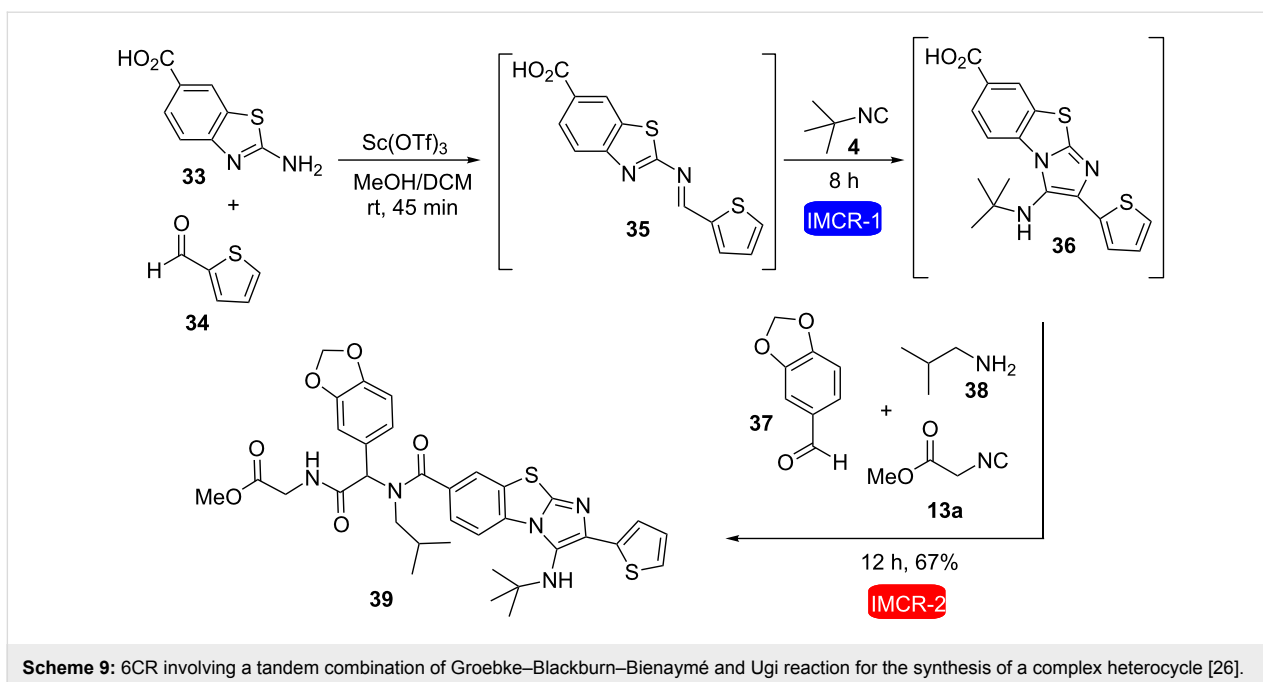
Al-Tel et al. described the tandem combination of Groebke–Blackburn–Bienaymé and Ugi or Passerini reactions in the same reaction flask without isolating any intermediate, allowing the preparation of complex heterocycles through sequential additions of five or six components [26]. For instance, compounds **39** and **44** were efficiently obtained in good yields using this strategy (Scheme 9 and Scheme 10, respectively) and many other examples were described in this work.



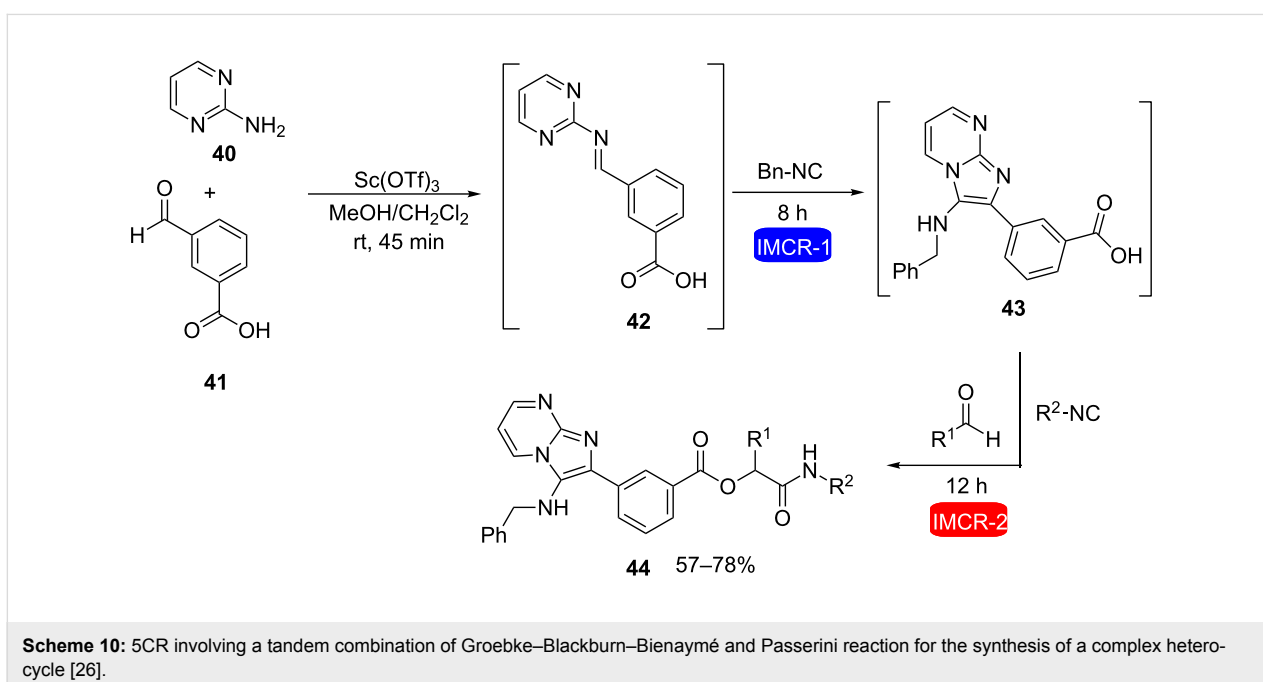
Scheme 7: One-pot 8CR based on 3 sequential IMCRs [25].



Scheme 8: Combination of IMCRs for the synthesis of substituted 2H-imidazolines [25].



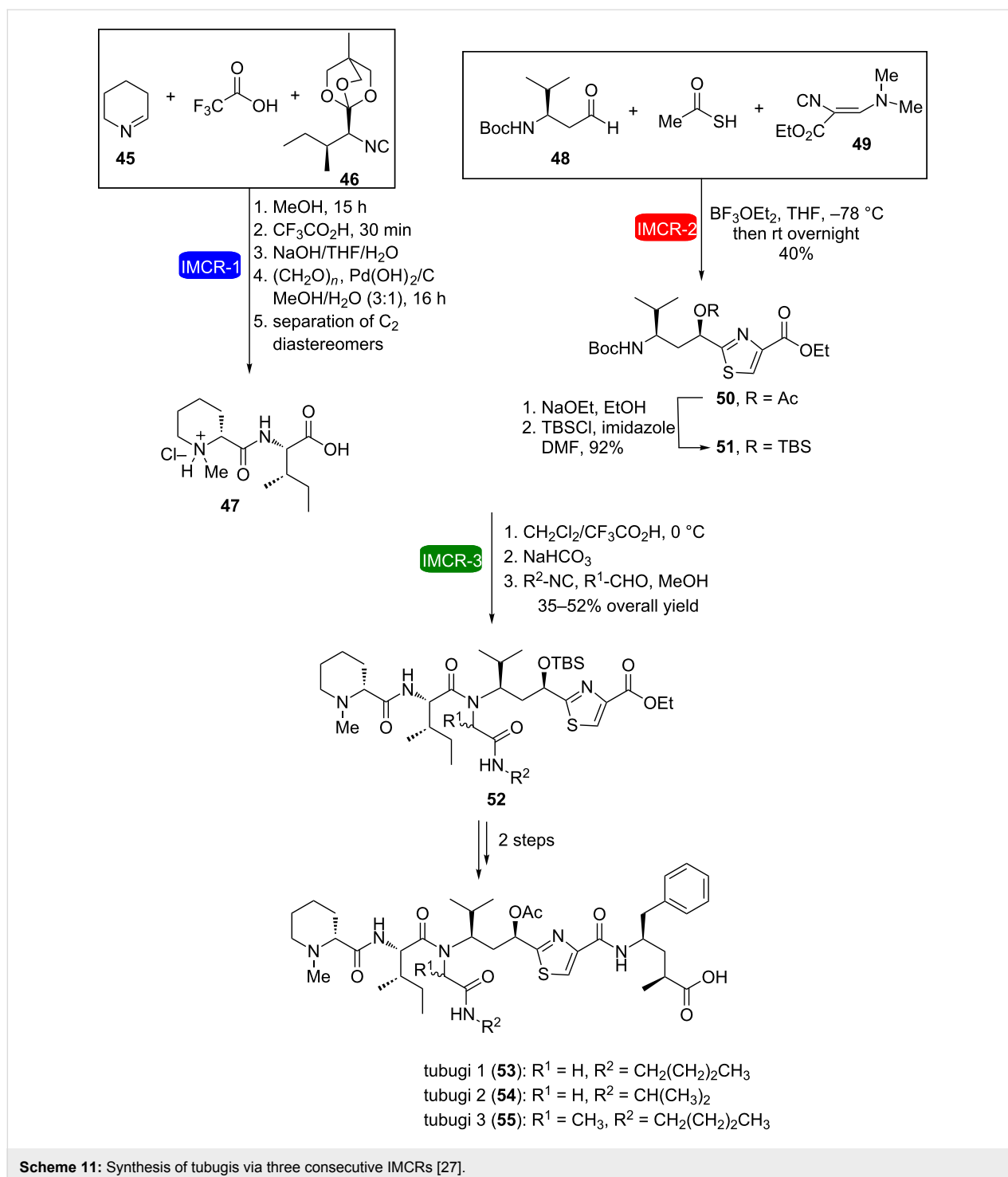
**Scheme 9:** 6CR involving a tandem combination of Groebke–Blackburn–Bienaymé and Ugi reaction for the synthesis of a complex heterocycle [26].



**Scheme 10:** 5CR involving a tandem combination of Groebke–Blackburn–Bienaymé and Passerini reaction for the synthesis of a complex heterocycle [26].

The strategy of consecutive IMCRs has also been successfully used in the synthesis of tubulysin analogues called tubugis (**53–55**) [27]. These molecules are *N*-substituted peptides, which possess a very high cytotoxic activity (on the picomolar range). They were prepared using three different IMCRs (Scheme 11): the Mep-Ileu-OH dipeptide fragment **47** was obtained as a diastereomeric mixture via an Ugi–Nenajdenko reaction using the 4-methyl-2,6,7-trioxabicyclo[2,2,2]octyl (OBO) ester **46** to avoid epimerization of the isocyanide, followed by a

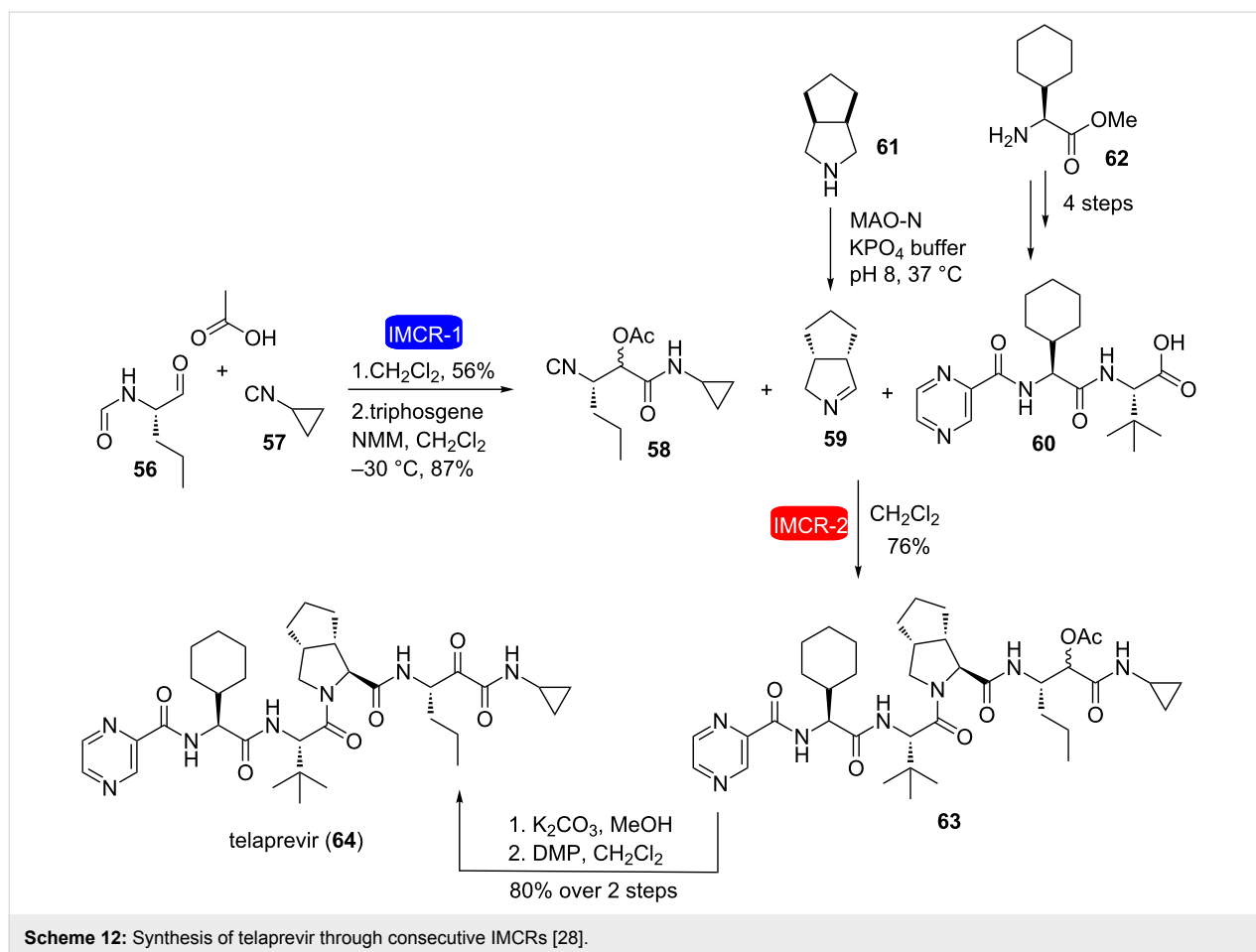
reductive amination and chromatographic separation of the isomers; a Passerini–Dömling IMCR led to the heterocyclic fragment of the molecule, called tubuvaline (**50**); and finally an Ugi reaction was used to couple them. Initial attempts to use tubuvaline **50** led to an undesirable product due to water attack at the reaction intermediate before Mumm rearrangement. This was circumvented by changing the protecting group of **50** from acetyl to *tert*-butyldimethylsilyl (TBS, compound **51**). The coupling of the fragments via Ugi reaction was carried out under



very controlled conditions, using a syringe pump to slowly add the isocyanide, thus avoiding the formation of the double-addition product.

Ruijter et al. performed the synthesis of telaprevir **64**, a protease inhibitor used in the treatment of hepatitis C, through a very short and efficient synthetic strategy involving as key steps two

IMCRs (Ugi and Passerini) [28]. The strategy involved the synthesis of isocyanide **58** via a Passerini reaction using aldehyde **56**, cyclopropyl isocyanide **57** and acetic acid, followed by reaction of the resulting formamide with triphosgene (Scheme 12). Compound **58** was obtained as a 78:22 diastereomeric ratio without any racemization of the pre-existing stereocenter and then used in the key step Ugi-type 3CR with cyclic



imine **59** (generated in situ from catalytic oxidation of amine **61**) and pyrazinecarboxylic acid **60** (readily available in four steps from L-cyclohexylglycine methyl ester (**62**)) to give compound **63**, which was converted to telaprevir (**64**) after two additional steps. This approach reduced by more than half the number of steps compared to the existing linear synthetic sequence for telaprevir.

Later on, Riva et al. reported an alternative synthesis of telaprevir using two consecutive IMCRs (Scheme 13) [29]. The first one is a Passerini-type reaction between aldehyde **66**, isocyanide **67** and boric acid, which yielded a 2:1 mixture of diastereomers. After converting **68** into aldehyde **69**, this was reacted with cyclopropyl isocyanide **57** and acetic acid (Passerini reaction) furnishing compound **70**, which was converted to telaprevir (**64**) in three additional steps.

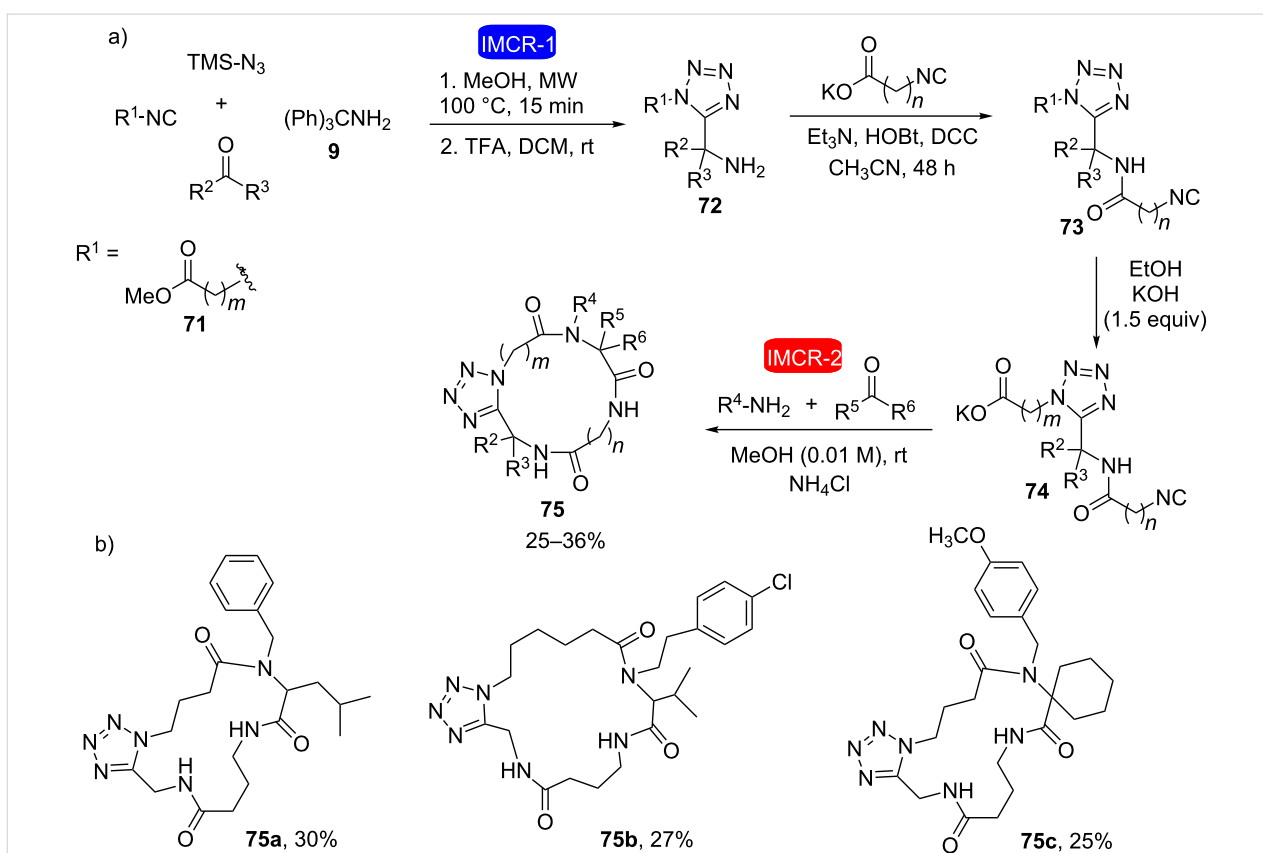
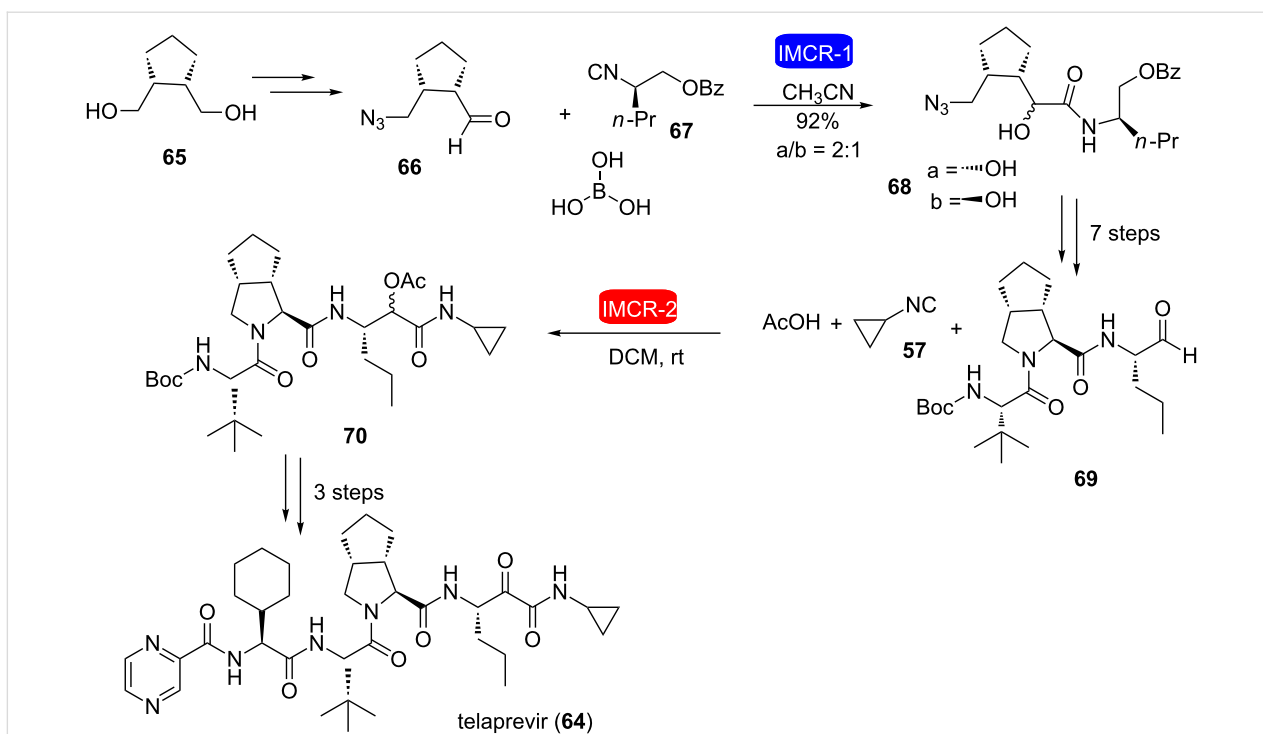
### Macrocyclic peptoid synthesis

Dömling et al. performed the combination of two isocyanide-based multicomponent reactions in the synthesis of macrocycles containing a tetrazole nucleus [30]. The strategy was based on the use of  $\alpha$ -isocyano- $\omega$ -carboxylic esters **71** via a

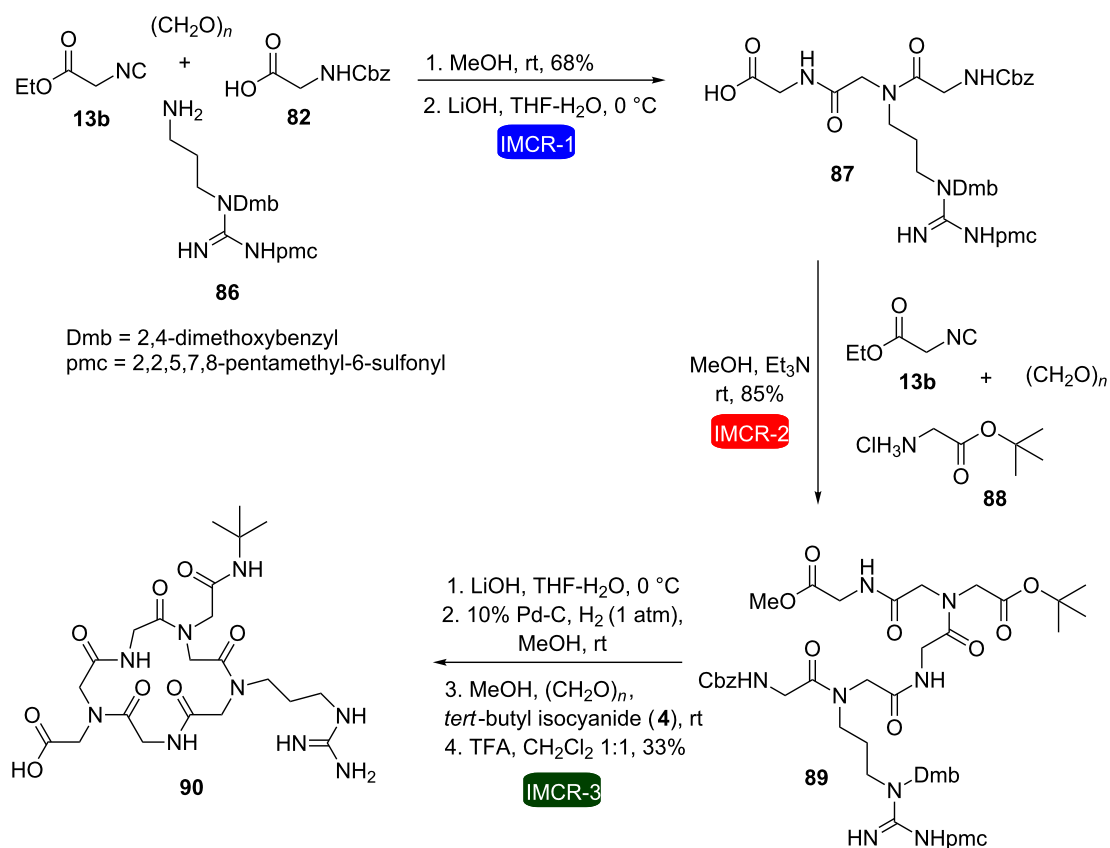
microwave-mediated Ugi-azide reaction at the beginning of the synthesis and an intramolecular Ugi reaction of bifunctional compounds **74** at the end, allowing the obtention of the 16- to 20-membered tetrazolic macrocycles **75** in only five steps (Scheme 14).

A similar approach was used shortly afterwards by the same research group in the synthesis of macrocyclic depsipeptides containing a tetrazole nucleus [31]. The combination of two isocyanide-based multicomponent reactions (azido-Ugi and Passerini reactions) allowed easy access to a library of macrocyclic depsipeptides in only four steps with variations in the size of the macrocycle as well as in the side chains (Scheme 15). This was the first example in which the intramolecular Passerini reaction was performed using bifunctional isocyanocarboxylate (Scheme 15a). Scheme 15b shows three of the 21 depsipeptides macrocycles synthesized by the authors in this study.

Ethyl isocyanoacetate (**13b**) has also been successfully used as starting material to allow consecutive Ugi reactions in the synthesis of macrocycles (which were considered as macrohetero-



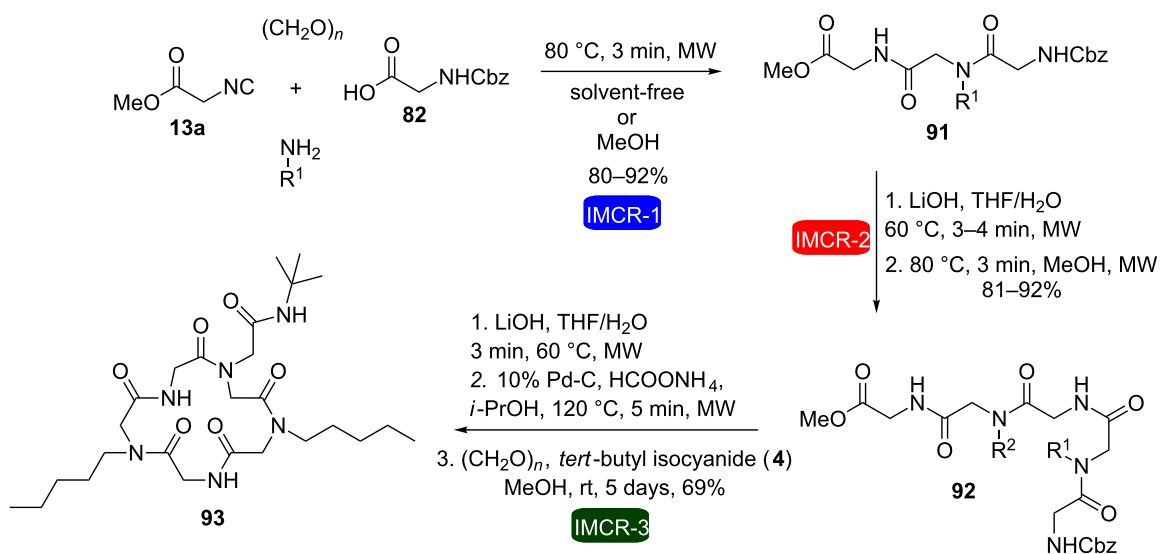




**Scheme 17:** Synthesis of a cyclic pentapeptoid by consecutive Ugi reactions [32].

in between. In this approach, by varying the amine component, the side chains of the peptoid backbone could be easily exchanged.

Later on, our group introduced the use of microwave heating to this same synthetic strategy for the synthesis of a cyclic peptoid (Scheme 18) [33]. The combination of these two tools (micro-



**Scheme 18:** MW-mediated synthesis of a cyclopeptoid by consecutive Ugi reactions [33].

wave heating and consecutive IMCRs) has proved to be a particularly attractive method for the synthesis of macroheterocycles, which could be easily accomplished in a reduced number of steps and very short reaction periods (except for the last step). Three consecutive Ugi reactions were performed followed by the respective hydrolysis and deprotection, furnishing an amino acid, which was cyclized in good yield to macrocycle **93** via an intramolecular Ugi three-component four-center reaction (U-3C-4CR).

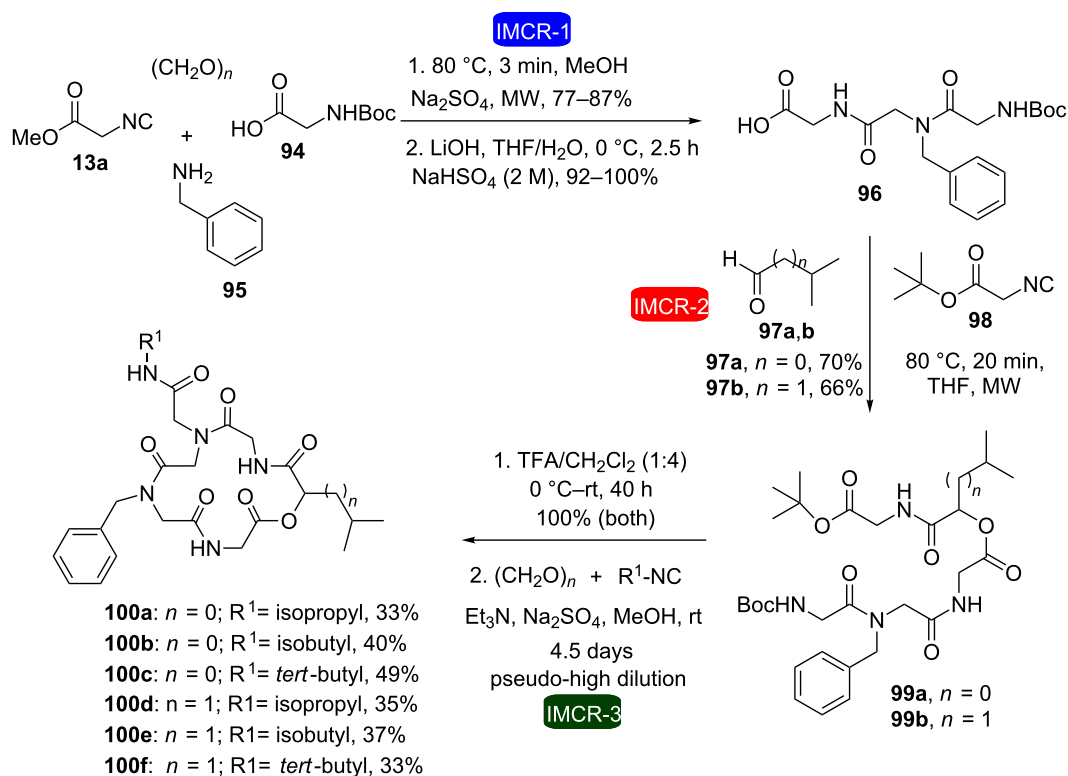
In the continuation of our studies, we used a similar strategy for the combination of consecutive isocyanide-based multicomponent reactions (Ugi and Passerini reactions) [34]. This methodology was used in the synthesis of six cyclic depsipeptoids inspired by the structure of the natural depsipeptide sansalvamide A, which involved five steps (Scheme 19). In the first step, formation of the peptoid was achieved via the first Ugi reaction. Then, subsequent hydrolysis of the ester was followed by formation of an acyclic depsipeptoid via Passerini reaction between acid **96**, isocyanide **98** and aldehydes **97**. Trifluoroacetic acid (TFA) allowed deprotection of the amine/acid groups. In the last step, a macrocyclization reaction via an intra-

molecular Ugi reaction provided the achievement of the cyclic depsipeptoids **100a–f** in yields ranging from 33–49% depending on the substrate.

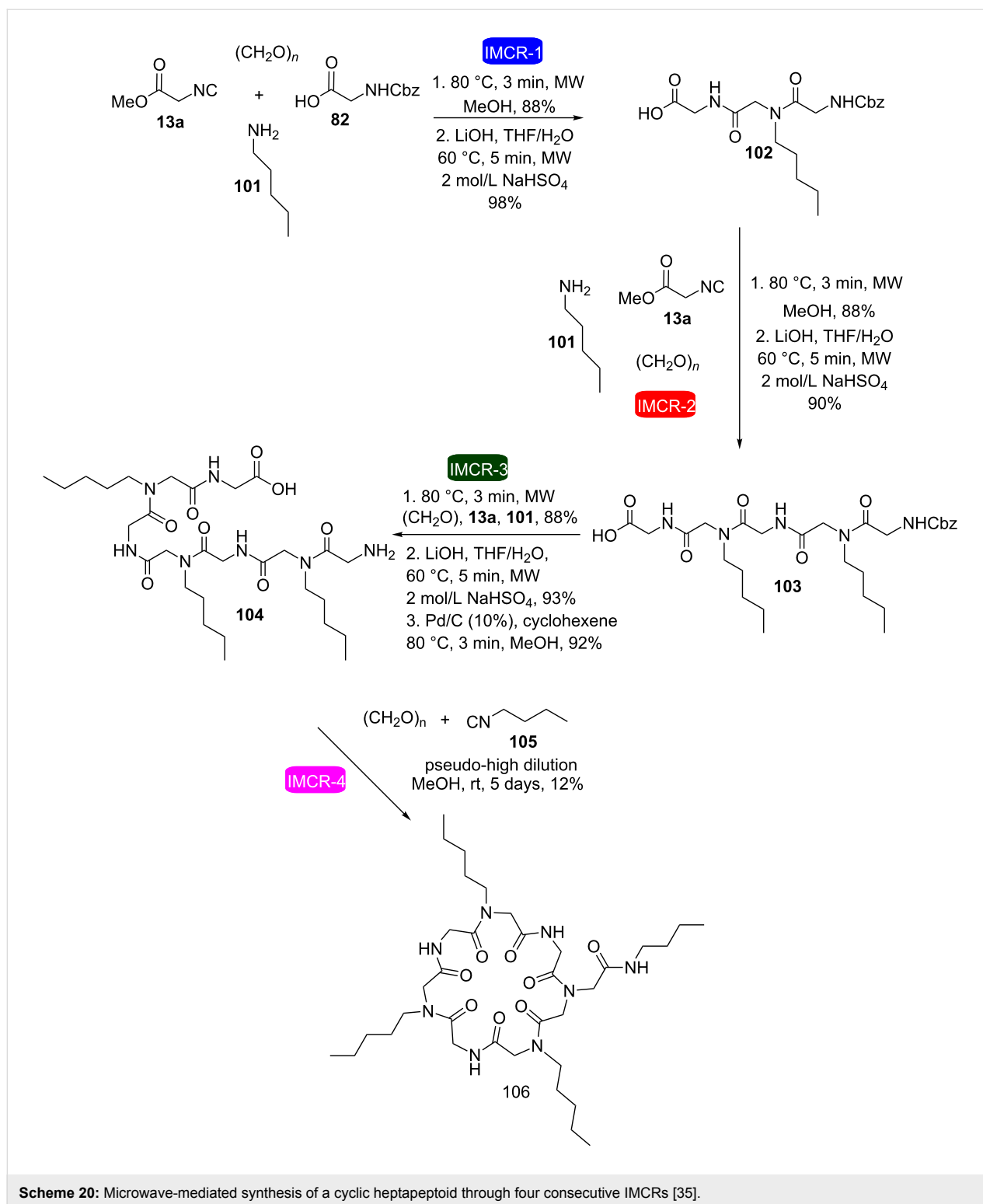
More recently, our research group described a fast and efficient strategy for the synthesis of macrocycles using four consecutive Ugi reactions (Scheme 20) [35]. This was the first example in the literature in which four consecutive IMCRs were employed. The strategy allowed the synthesis of a cyclic heptapeptoid in only 8 steps using microwave irradiation in seven of these steps allowing short reaction times (3–5 minutes) and excellent yields of the intermediates (88–98%). The non-optimized low yield of the last step was attributed to difficulties during the purification step along with to some oligomerization that might have occurred.

### Repetitive IMCRs – multicomponent macrocyclizations through bifunctional building blocks

A strategy that has been widely used for the synthesis of macroheterocycles is the multiple multicomponent macrocyclizations including bifunctional building blocks ( $M^3iB^3$ s or MiBs). In

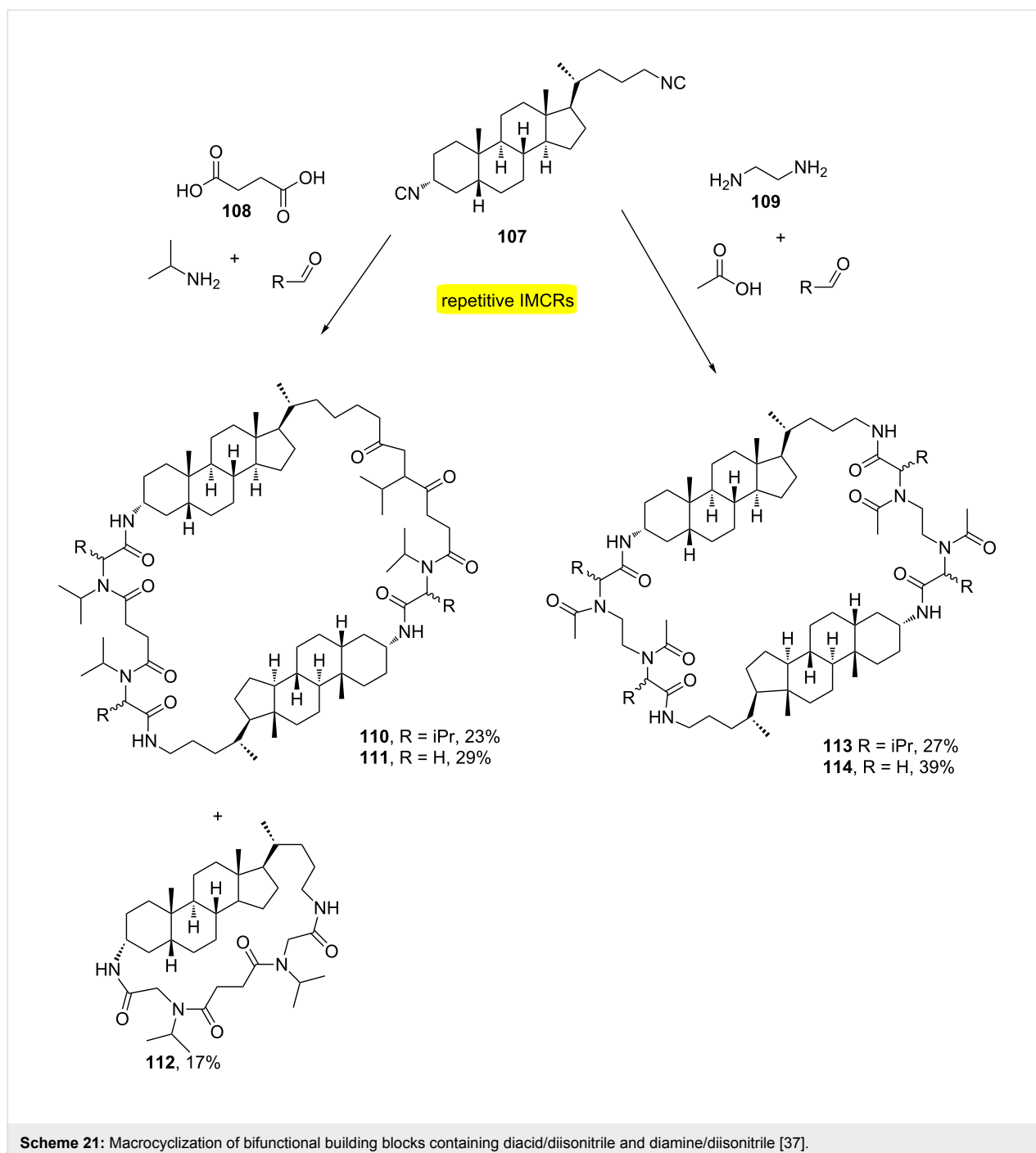


**Scheme 19:** Synthesis of six cyclic pentadepsipeptoids via consecutive isocyanide-based IMCRs [34].



this type of strategy, several subtypes of such reactions are conceivable varying the number and the type of IMCRs [36]. In this sense, Wessjohann and co-workers presented a direct method to generate chimeric peptoid macrocycles containing steroid moieties [37]. The process was based on designing a

4-fold Ugi-4CR macrocyclization by using the steroidal diisocyanide **107** with diacid **108** or diamine **109** (Scheme 21). According to the authors, this was the first report of repetitive multicomponent reactions to be used directly to obtain macrocycles of this complexity and size.

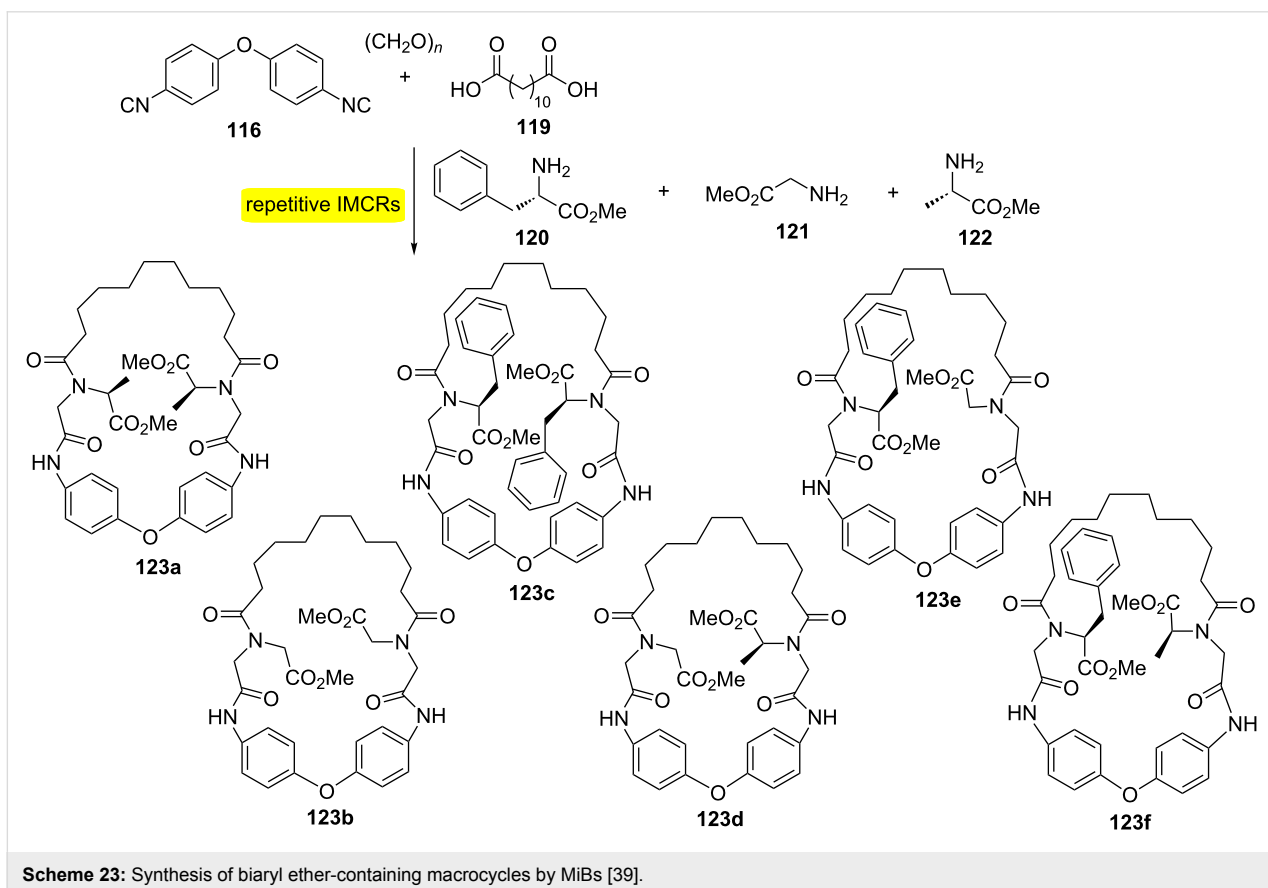
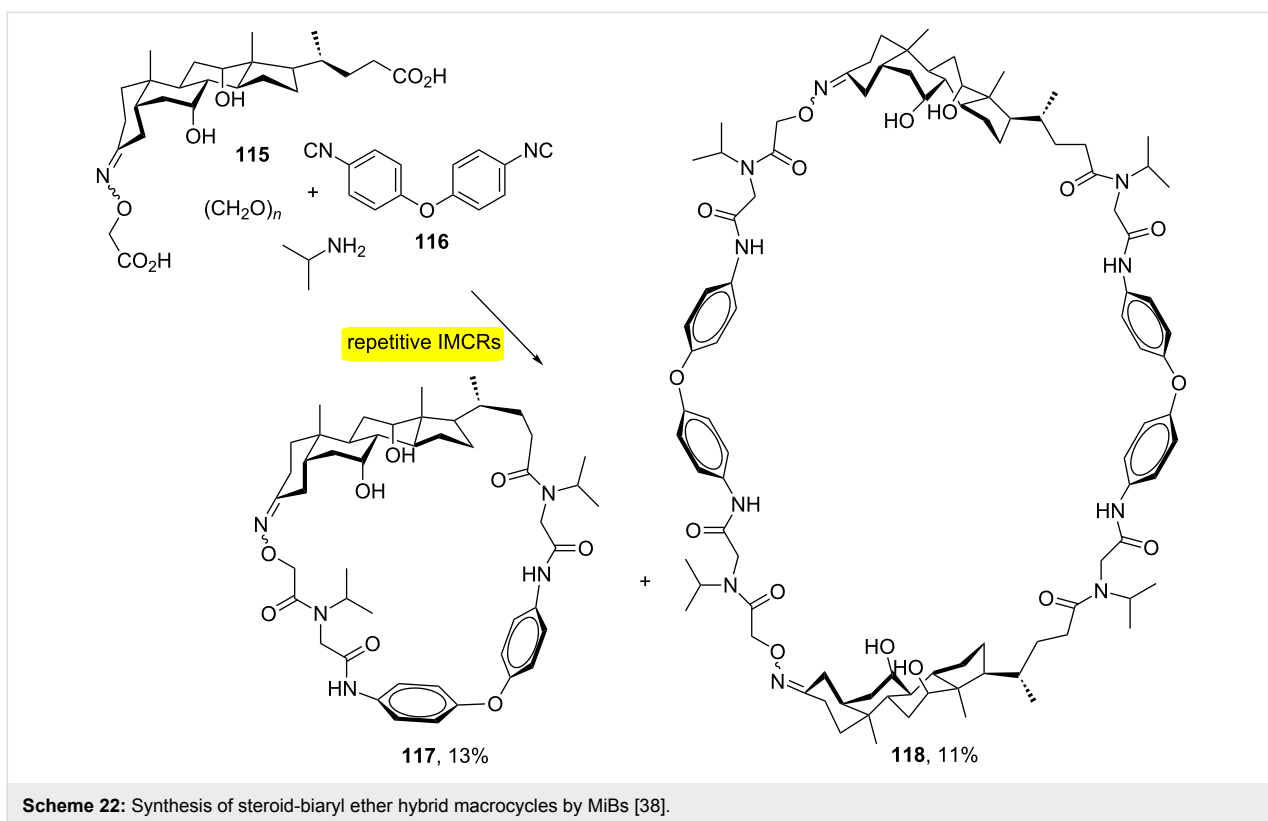


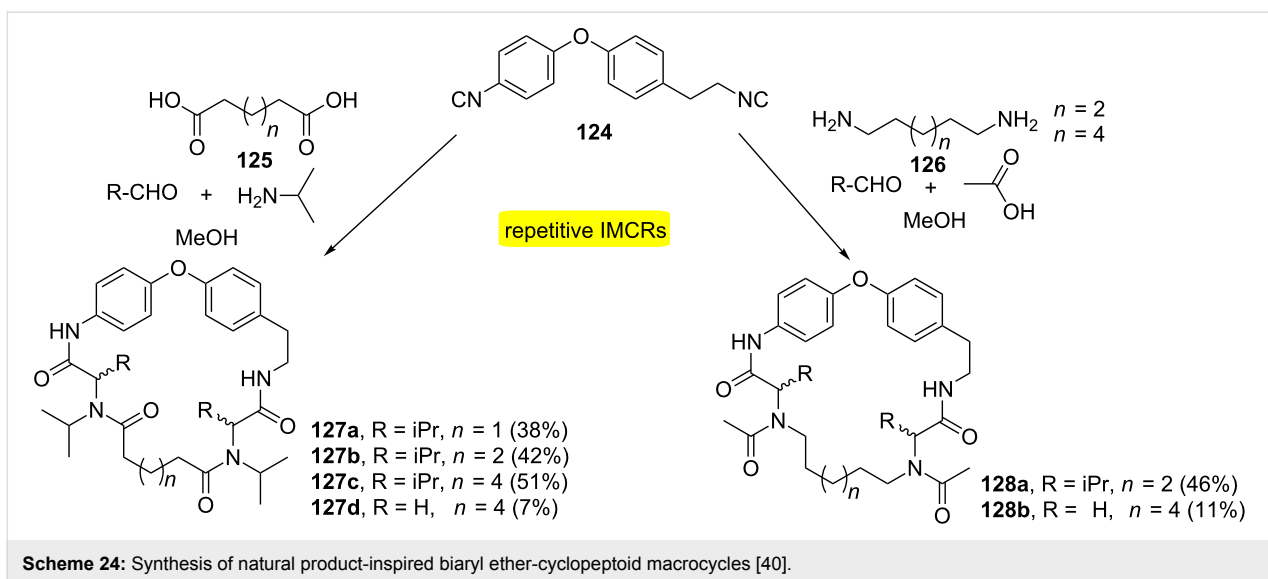
The synthesis of macrocycles with up to 16 new bonds being formed simultaneously has been described (Scheme 22). The strategy was based on combining steroidal dicarboxylic acids **115** and biaryl ether diisocyanide **116** [38]. The approach provided the synthesis of steroid-biaryl ether hybrid macrocycles **117** and **118** with up to 68 members by the MiBs strategy.

Another representative example of MiBs is the synthesis of the biaryl ether-containing macrocycles **123a–f** (Scheme 23) [39].

The synthetic strategy involved the mixing of three different C-protected amino acids (**120–122**) with diisocyanide **116** and diacid **119**. The approach allowed the one pot obtention of six different macrocycles and a macrocycle core system containing two symmetrical building blocks.

This same strategy has also been carried out for the synthesis of natural products containing biaryl ether-cyclopeptoid macrocycles **127** and **128** (Scheme 24) [40]. The approach used



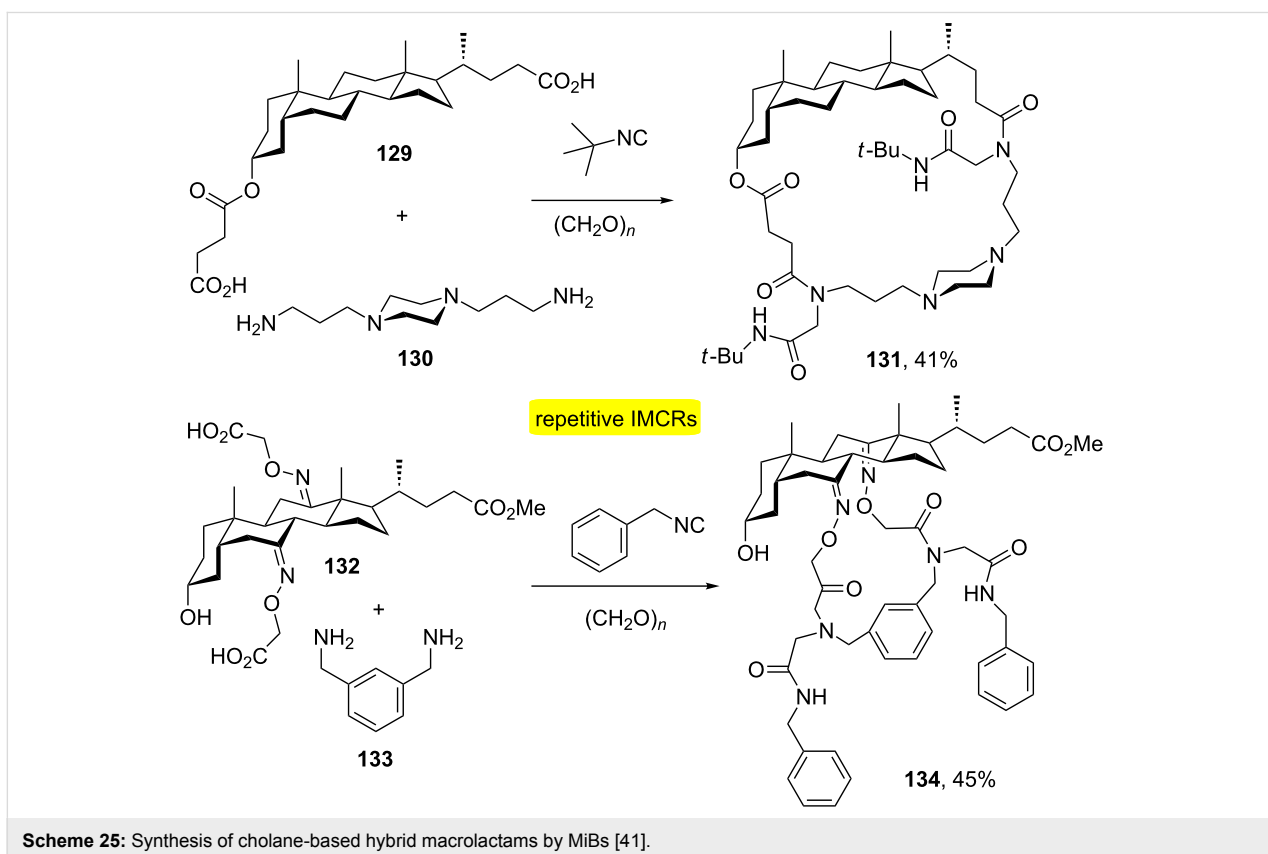


involved diisocyanides **124** (representing a biaryl ether moiety) reacting with aliphatic diacid/diamine and amine/aldehyde, respectively, to generate the target macroheterocycles.

Wessjohann and Rivera [41] performed the first use of the diamine/diacid combination of bidirectional Ugi-MiBs in the synthesis of novel steroid-peptoid hybrid macrocycles. Scheme 25

shows two examples using this combination for the synthesis of cholane-peptoid hybrid macrocycles.

Another application of the MiBs approach has been found in the use of dynamic combinatorial chemistry (DCC) [42]. One of the most accessible reversible bonds is the imine bond and has been widely used in DCC. In this context, a freezing process of a

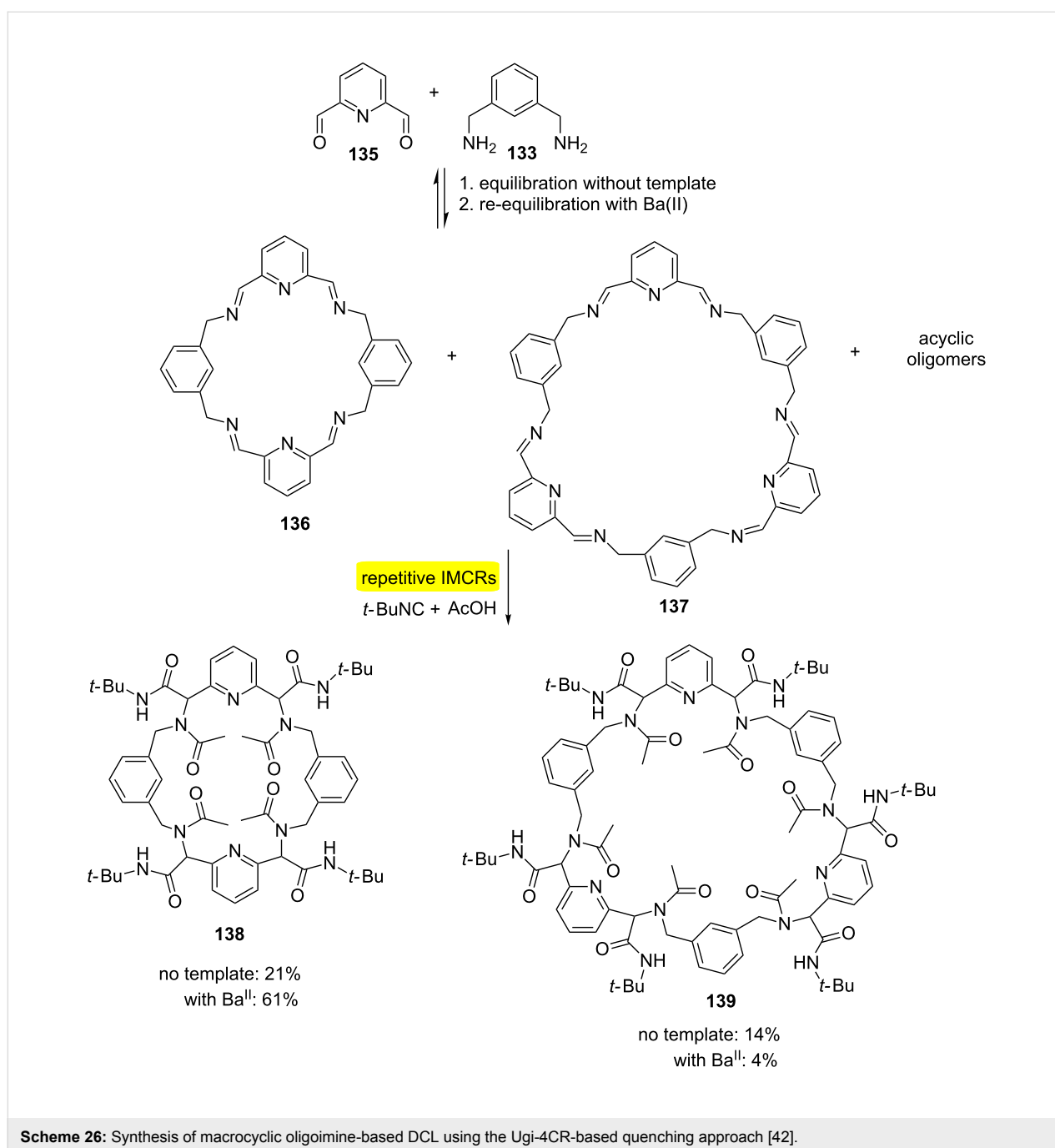


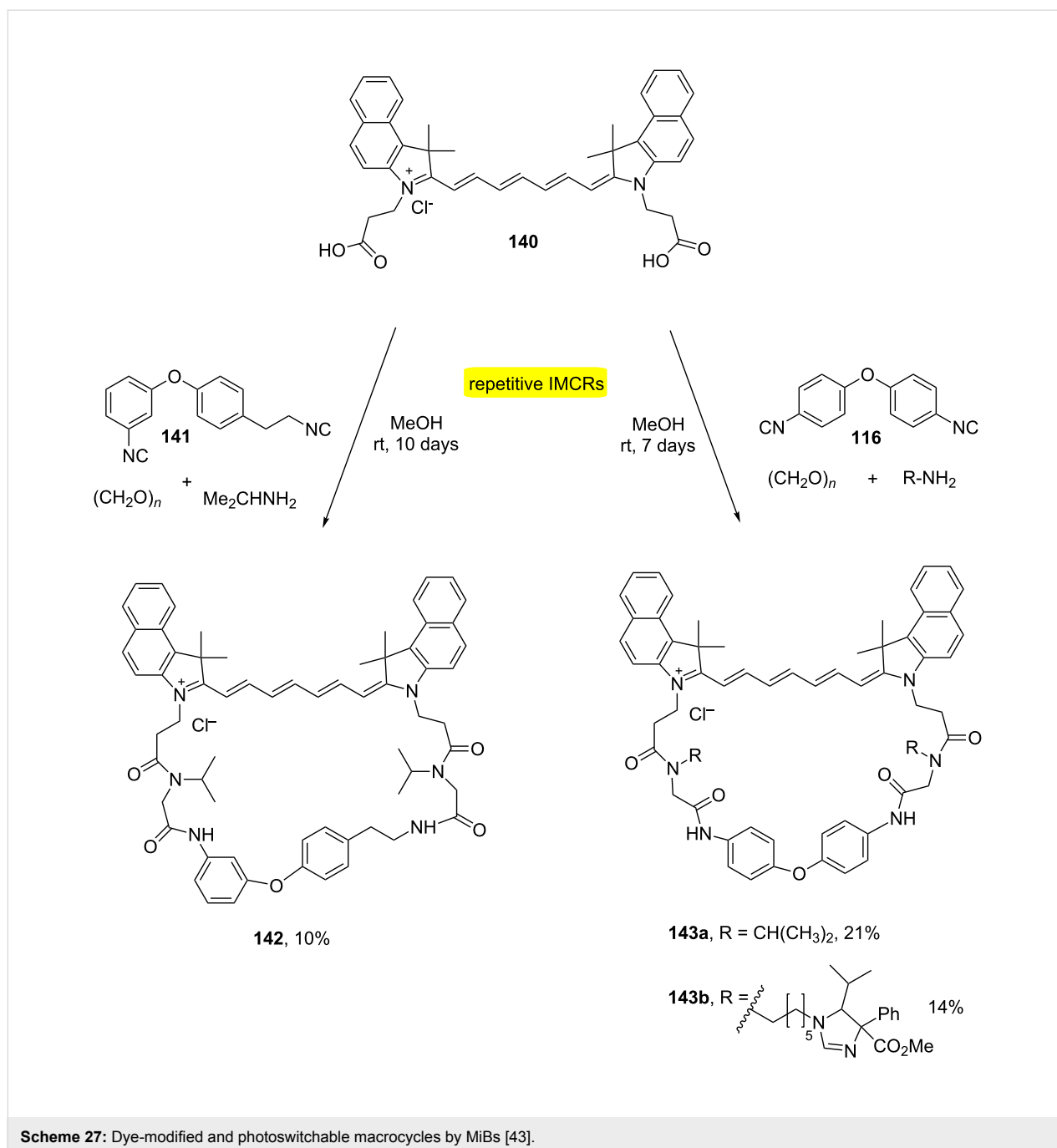
dynamic combinatorial library (DCL), which is a system of recognition and thermodynamic control, has been developed using multiple Ugi-4CRs (Scheme 26). This approach allows the obtention of macrocycles without the use of pseudo-high-dilution protocol and addition of Ba(II) allowed better results of the final product. This combination has allowed the first selective formation of a 6-fold Ugi-MiB.

Functional macrocycles have been developed with dye-modified and photoswitchable moieties by MiBs [43]. The approach

employed the use of bifunctionalized near-infrared (NIR) dyes containing two carboxylic acid moieties with diisocyanide building blocks providing the formation of somewhat flexible 34- and 35-membered macroheterocycles **142** and **143** in yields ranging from 10 to 21% after long reactional times (Scheme 27).

There are some interesting examples in which repetitive and consecutive IMCRs were used in a combined fashion. For instance, Wessjohann and Rivera [44] performed the synthesis

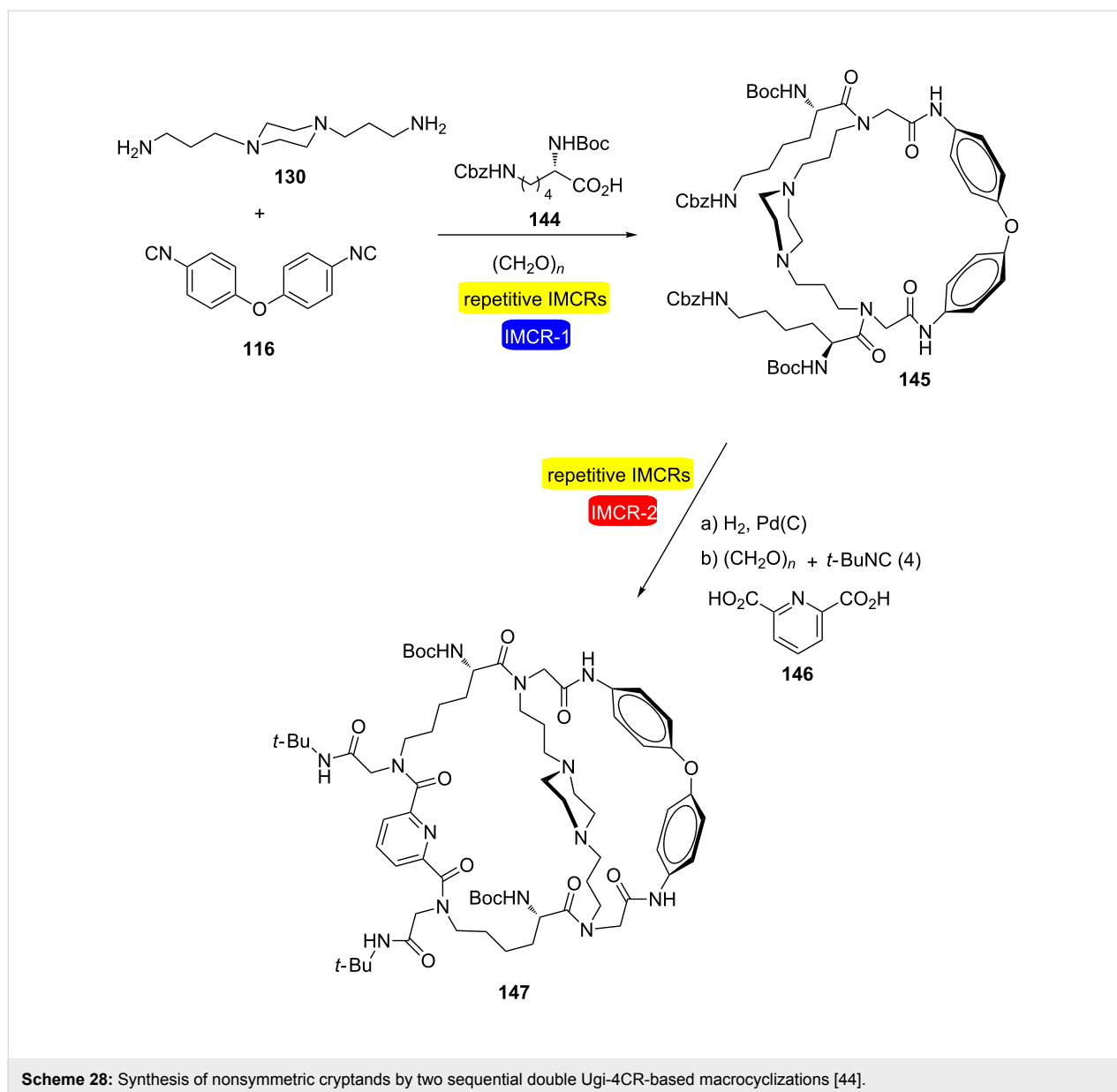




of nonsymmetric cryptands by two sequential double Ugi-4CR-based macrocyclizations (Scheme 28). The approach also relies on MiBs strategy [45]. The main focus was on the use of the Ugi four-component reaction (Ugi-4CR) due to the tremendous capability of this process to generate molecular complexity. In the approach, one of the building blocks taking part in the first Ugi-MiB must contain a protected, Ugi-reactive functional group to be subsequently activated for the next macrocyclization. In this way, after the first double Ugi reaction between diamine **130**, diisocyanide **116**, paraformaldehyde and acid **144**,

Cbz removal of the macrocycle **145** formed led to another diamine intermediate that was involved in a second double Ugi reaction with paraformaldehyde, *tert*-butyl isocyanide and diacid **146**, to yield cryptand **147** in 31% overall yield from **130**. Other macroheterocycles were synthesized in this study using this same protocol.

Using this same combined approach, Wessjohann and Rivera developed a very efficient strategy for the synthesis of supramolecular compounds via Ugi-type multiple multicomponent

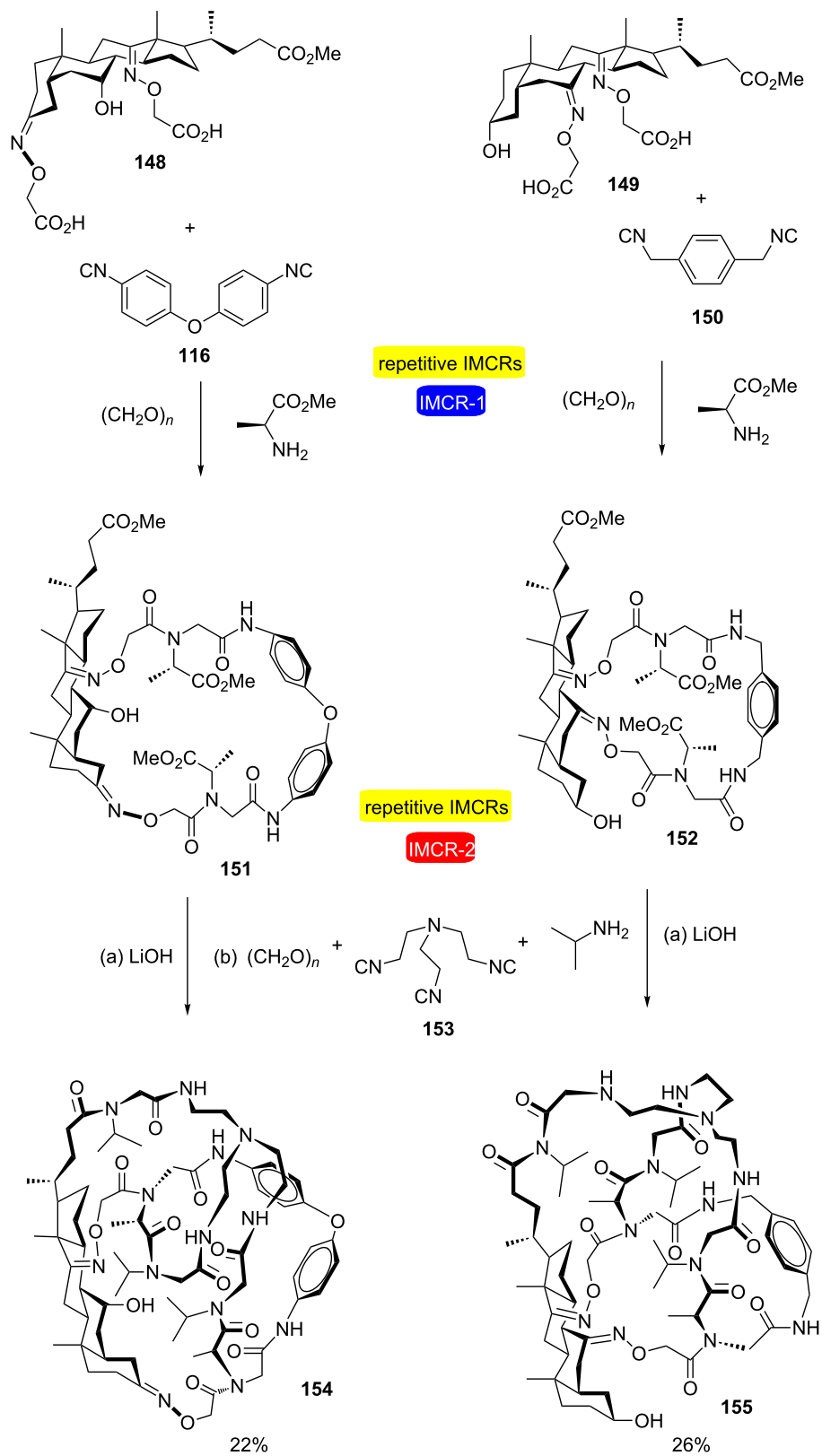


macrocyclizations of polyfunctional building blocks (Scheme 29) [46]. An initial double Ugi-4CR-based macrocyclization yielded steroid-aryl hybrid macroheterocycles **151** and **152**, which after ester hydrolysis, acted as trifunctional building blocks for consecutive 3-fold Ugi-4CR-based macrocyclizations with triisocyanide **153**. The cross-linked igloo-shaped skeletons of cages **154** and **155** were obtained in a remarkable one-pot reaction sequence, which involved the incorporation of 13 building blocks and the formation of 20 new bonds without the need of isolating any intermediate in the process.

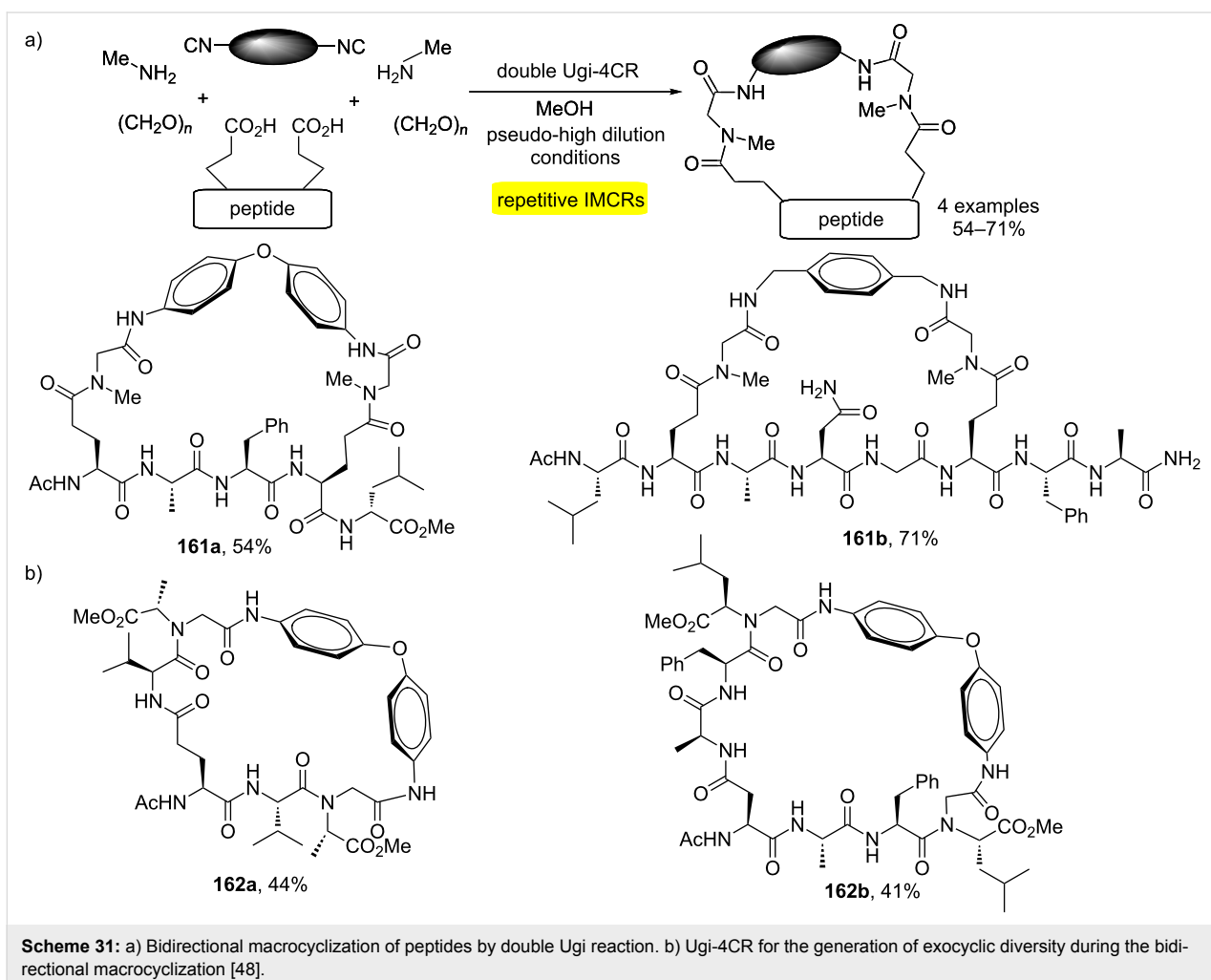
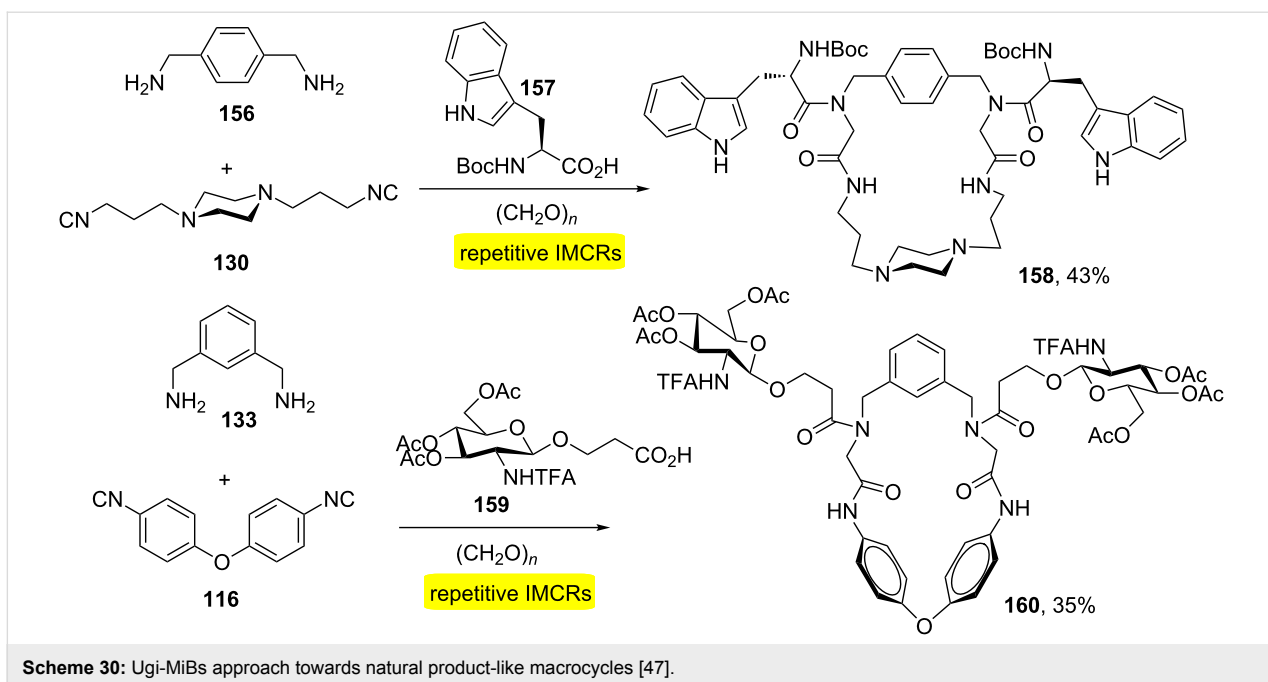
Wessjohann and co-workers demonstrated that the MiBs strategy could be easily used to obtain several bidirectional macrocycles with exocyclic substituents with side chains

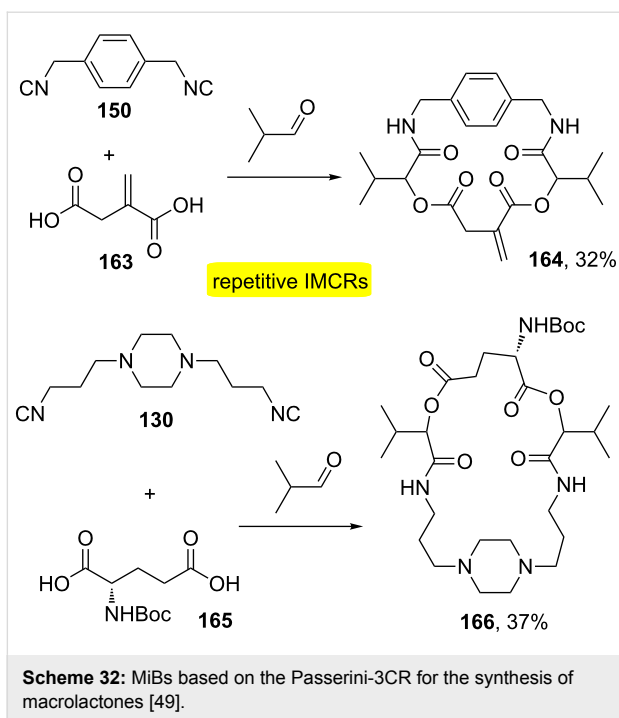
derived from natural products [47]. The combination of acid components with side chains derived from natural products containing amino acid residues (e.g., Arg, Cys, His, Trp) and sugar, bifunctional components (diamino/diisocyanide) and formaldehyde allowed the rapid production of eight functionalized macrocycles (Scheme 30).

Another method using repetitive Ugi reactions has been described for the macrocyclization of peptides [48]. The approach was based on double Ugi-4CR involving a peptide diacid, a diisocyanide, methylamine and paraformaldehyde (Scheme 31a). Subsequently, it was observed that varying the amine component (*C*-protected amino acids) allowed the obtention of exocyclic elements of diversity as observed in macro-



**Scheme 29:** Synthesis of steroid–aryl hybrid cages by sequential 2- and 3-fold Ugi-4CR-based macrocyclizations [46].

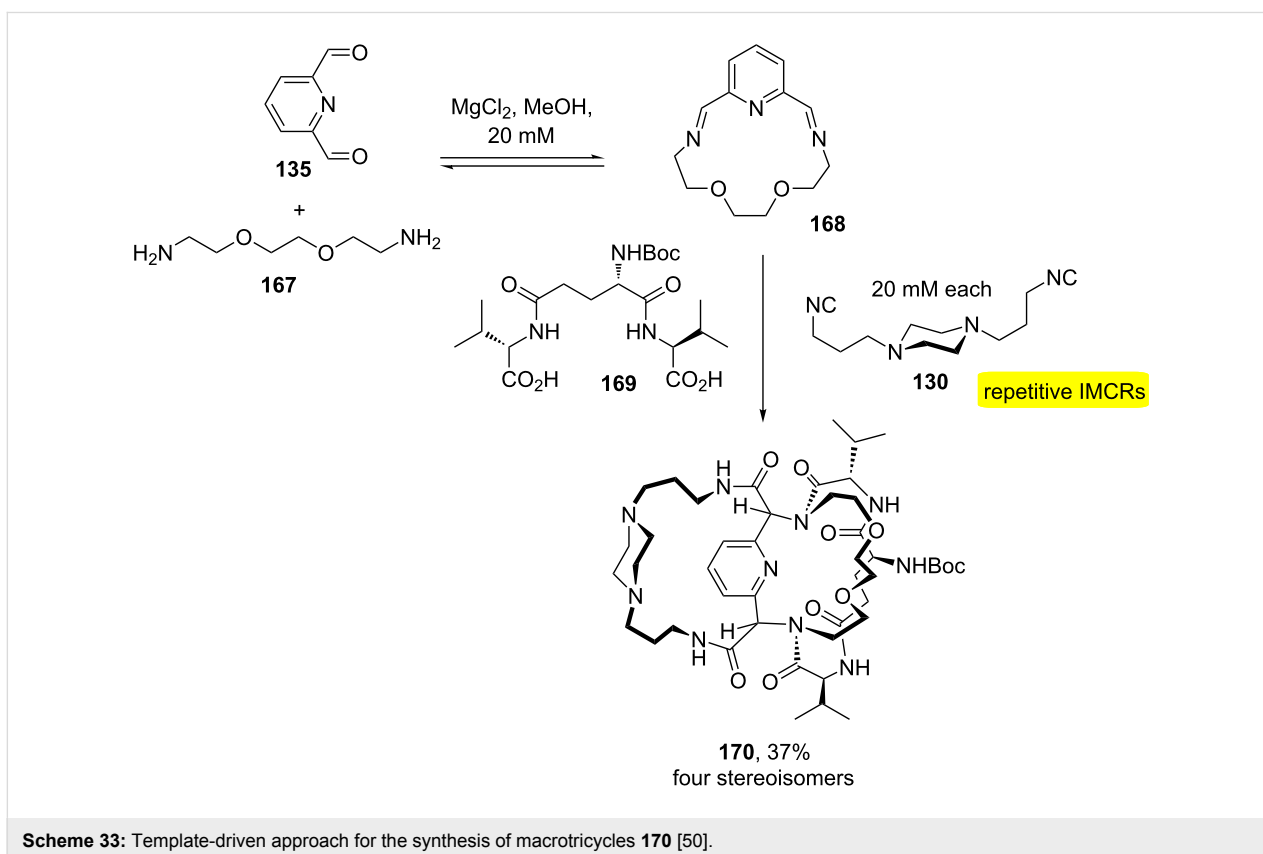




cycles **162a** and **b** (Scheme 31b). The process allows the increase of the peptide sequence as well as the inclusion of conformational constraints.

Wessjohann and co-workers also demonstrated MiBs based on the Passerini-3CR [49]. The strategy is similar to Ugi-MiBs in which it provides molecular diversity in a few steps due to variable combinations of bifunctional building blocks that can be easily changed to provide skeletal diversity in macrocycles. In this approach, two different bifunctional building blocks were combined: diacid/diisocyanide (Scheme 32). This approach also allows the combination of diacid/dialdehyde and dialdehyde/diisocyanide. Macrolactones **164** and **166** were readily obtained using readily available starting materials. Diisocyanides were prepared from commercial diamines in two steps: formylation followed by dehydration of the diformamides. The easiness to obtain the starting materials provides a variety of macrocycles using the Passerini-MiBs.

Recently, the use of a double Ugi four-component macrocyclization for the synthesis of molecular cages was described [50]. The approach was based on macromulticycle connectivities through bridgeheads. For the macrocyclization reaction, metal-template-driven and dilution conditions were used. These conditions allowed one-pot synthesis including aryl, heterocyclic, polyether, peptidic and steroidal tethers. Scheme 33 shows a template-driven approach to macrotricycles **170**, which were obtained from preformed diimine **168** and addition of diacid **169** and diisocyanide **130** as building blocks.



## Conclusion

Based on the many examples shown herein, one can conclude that the strategies of repetitive and consecutive isocyanide-based multicomponent reactions can furnish a great variety of different (macro)heterocycles in a short number of steps and with good overall yields in most cases. The strategies are even more powerful when coupled with microwave-mediated reactions, allowing a fast and reproducible synthesis of more complex products. It can be foreseen that this useful strategy will continue to be applied to the synthesis of molecules with even more structural diversity.

## Acknowledgements

CNPq, CAPES and the Universidade de Brasília are acknowledged for financial support.

## ORCID® iDs

Carlos Kleber Z. Andrade - <https://orcid.org/0000-0003-0798-9133>

## References

- Lieke, W. *Justus Liebigs Ann. Chem.* **1859**, *112*, 316–321. doi:10.1002/jlac.18591120307
- Dömling, A.; Ugi, I. *Angew. Chem., Int. Ed.* **2000**, *39*, 3168–3210. doi:10.1002/1521-3773(20000915)39:18<3168::aid-anie3168>3.0.co;2-u
- Dömling, A. *Chem. Rev.* **2006**, *106*, 17–89. doi:10.1021/cr0505728
- Koopmanschap, G.; Ruijter, E.; Orru, R. V. A. *Beilstein J. Org. Chem.* **2014**, *10*, 544–598. doi:10.3762/bjoc.10.50
- Váradi, A.; Palmer, T. C.; Dardashti, R. N.; Majumdar, S. *Molecules* **2016**, *21*. doi:10.3390/molecules21010019
- Orru, R. V. A.; Ruijter, E., Eds. *Synthesis of Heterocycles via Multicomponent Reactions II; Topics in Heterocyclic Chemistry*; Springer Berlin: Berlin, Germany, 2010. doi:10.1007/978-3-642-15455-3
- Ameta, K. L.; Dandia, A. *Multicomponent Reactions: Synthesis of Bioactive Heterocycles*; CRC Press, 2017.
- Kazemizadeh, A. R.; Ramazani, A. *Curr. Org. Chem.* **2012**, *16*, 418–450. doi:10.2174/138527212799499868
- Zhu, J.; Wang, Q.; Wang, M., Eds. *Multicomponent Reactions in Organic Synthesis*; Wiley-VCH, 2015.
- Herrera, R. P.; Marqués-López, E., Eds. *Multicomponent Reactions*; John Wiley & Sons, Inc: Hoboken, NJ, 2015. doi:10.1002/9781118863992
- Dömling, A.; Wang, W.; Wang, K. *Chem. Rev.* **2012**, *112*, 3083–3135. doi:10.1021/cr100233r
- Andrade, C. K. Z.; Dar, A. R. *Tetrahedron* **2016**, *72*, 7375–7391. doi:10.1016/j.tet.2016.09.055
- Strecker, A. *Ann. Chem. Pharm.* **1850**, *75*, 27–45. doi:10.1002/jlac.18500750103
- Ugi, I.; Meyr, R.; Fetzer, U.; Steinbruckner, C. *Angew. Chem.* **1959**, *71*, 386–388.
- Zarganes-Tzitzikas, T.; Chandgude, A. L.; Dömling, A. *Chem. Rec.* **2015**, *15*, 981–996. doi:10.1002/tcr.201500201
- Brauch, S.; van Berkel, S. S.; Westermann, B. *Chem. Soc. Rev.* **2013**, *42*, 4948–4962. doi:10.1039/c3cs35505e
- Constabel, F.; Ugi, I. *Tetrahedron* **2001**, *57*, 5785–5789. doi:10.1016/s0040-4020(01)00516-6
- Gulevich, A. V.; Zhdanko, A. G.; Orru, R. V. A.; Nenajdenko, V. G. *Chem. Rev.* **2010**, *110*, 5235–5331. doi:10.1021/cr900411f
- Zarganes-Tzitzikas, T.; Patil, P.; Khoury, K.; Herdtweck, E.; Dömling, A. *Eur. J. Org. Chem.* **2015**, 51–55. doi:10.1002/ejoc.201403401
- Neochoritis, C. G.; Zhao, T.; Dömling, A. *Chem. Rev.* **2019**, *119*, 1970–2042. doi:10.1021/acs.chemrev.8b00564
- Gunawan, S.; Hulme, C. *Org. Biomol. Chem.* **2013**, *11*, 6036–6046. doi:10.1039/c3ob40900g
- Barreto, A. d. F. S.; Santos, V. A. d.; Andrade, C. K. Z. *Beilstein J. Org. Chem.* **2017**, *13*, 2596–2602. doi:10.3762/bjoc.13.256
- Patil, P.; Mishra, B.; Sheombarsing, G.; Kurpiewska, K.; Kalinowska-Tłuścik, J.; Dömling, A. *ACS Comb. Sci.* **2018**, *20*, 70–74. doi:10.1021/acscombsci.7b00137
- Madhavachary, R.; Wang, Q.; Dömling, A. *Chem. Commun.* **2017**, 53, 8549–8552. doi:10.1039/c7cc03370b
- Elders, N.; van der Born, D.; Hendrickx, L. J. D.; Timmer, B. J. J.; Krause, A.; Janssen, E.; de Kanter, F. J. J.; Ruijter, E.; Orru, R. V. A. *Angew. Chem., Int. Ed.* **2009**, *48*, 5856–5859. doi:10.1002/anie.200902683
- Al-Tel, T. H.; Al-Qawasmeh, R. A.; Voelter, W. *Eur. J. Org. Chem.* **2010**, 5586–5593. doi:10.1002/ejoc.201000808
- Pando, O.; Stark, S.; Denkert, A.; Porzel, A.; Preusentanz, R.; Wessjohann, L. A. *J. Am. Chem. Soc.* **2011**, *133*, 7692–7695. doi:10.1021/ja2022027
- Znabet, A.; Polak, M. M.; Janssen, E.; Kanter, F. J. J.; Turner, N. J.; Orru, R. V. A.; Ruijter, E. *Chem. Commun.* **2010**, 46, 7918–7920. doi:10.1039/c0cc02823a
- Moni, L.; Banfi, L.; Basso, A.; Carcone, L.; Rasparini, M.; Riva, R. *J. Org. Chem.* **2015**, *80*, 3411–3428. doi:10.1021/jo502829j
- Liao, G. P.; Abdelraheem, E. M. M.; Neochoritis, C. G.; Kurpiewska, K.; Kalinowska-Tłuścik, J.; McGowan, D. C.; Dömling, A. *Org. Lett.* **2015**, *17*, 4980–4983. doi:10.1021/acs.orglett.5b02419
- Abdelraheem, E. M. M.; Kurpiewska, K.; Kalinowska-Tłuścik, J.; Dömling, A. *J. Org. Chem.* **2016**, *81*, 8789–8795. doi:10.1021/acs.joc.6b01430
- Vercillo, O. E.; Andrade, C. K. Z.; Wessjohann, L. A. *Org. Lett.* **2008**, *10*, 205–208. doi:10.1021/ol702521g
- Barreto, A. d. F. S.; Vercillo, O. E.; Birkett, M. A.; Caulfield, J. C.; Wessjohann, L. A.; Andrade, C. K. Z. *Org. Biomol. Chem.* **2011**, *9*, 5024–5027. doi:10.1039/c1ob05471f
- Barreto, A. d. F. S.; Vercillo, O. E.; Wessjohann, L. A.; Andrade, C. K. Z. *Beilstein J. Org. Chem.* **2014**, *10*, 1017–1022. doi:10.3762/bjoc.10.101
- Barreto, A. d. F. S.; Andrade, C. K. Z. *Tetrahedron* **2018**, *74*, 6861–6865. doi:10.1016/j.tet.2018.10.018
- Wessjohann, L. A.; Ruijter, E. *Mol. Diversity* **2005**, *9*, 159–169. doi:10.1007/s11030-005-1313-y
- Wessjohann, L. A.; Voigt, B.; Rivera, D. G. *Angew. Chem.* **2005**, *117*, 4863–4868. doi:10.1002/ange.200500019
- Wessjohann, L. A.; Rivera, D. G.; Coll, F. *J. Org. Chem.* **2006**, *71*, 7521–7526. doi:10.1021/jo0608570
- Rivera, D. G.; Vercillo, O. E.; Wessjohann, L. A. *Synlett* **2007**, 308–312. doi:10.1055/s-2007-968006
- Michalik, D.; Schaks, A.; Wessjohann, L. A. *Eur. J. Org. Chem.* **2007**, 149–157. doi:10.1002/ejoc.200600354
- Rivera, D. G.; Wessjohann, L. A. *Molecules* **2007**, *12*, 1890–1899. doi:10.3390/12081890

42. Wessjohann, L. A.; Rivera, D. G.; León, F. *Org. Lett.* **2007**, *9*, 4733–4736. doi:10.1021/ol7021033
43. Kreye, O.; Westermann, B.; Rivera, D. G.; Johnson, D. V.; Orru, R. V. A.; Wessjohann, L. A. *QSAR Comb. Sci.* **2006**, *25*, 461–464. doi:10.1002/qsar.200540217
44. Rivera, D. G.; Wessjohann, L. A. *J. Am. Chem. Soc.* **2009**, *131*, 3721–3732. doi:10.1021/ja809005k
45. Wessjohann, L. A.; Rivera, D. G.; Vercillo, O. E. *Chem. Rev.* **2009**, *109*, 796–814. doi:10.1021/cr8003407
46. Rivera, D. G.; Wessjohann, L. A. *J. Am. Chem. Soc.* **2006**, *128*, 7122–7123. doi:10.1021/ja060720r
47. Rivera, D. G.; Vercillo, O. E.; Wessjohann, L. A. *Org. Biomol. Chem.* **2008**, *6*, 1787–1795. doi:10.1039/b715393g
48. Ricardo, M. G.; Morales, F. E.; Garay, H.; Reyes, O.; Vasilev, D.; Wessjohann, L. A.; Rivera, D. G. *Org. Biomol. Chem.* **2015**, *13*, 438–446. doi:10.1039/c4ob01915f
49. Leon, F.; Rivera, D. G.; Wessjohann, L. A. *J. Org. Chem.* **2008**, *73*, 1762–1767. doi:10.1021/jo7022125
50. Wessjohann, L. A.; Kreye, O.; Rivera, D. G. *Angew. Chem., Int. Ed.* **2017**, *56*, 3501–3505. doi:10.1002/anie.201610801

## License and Terms

This is an Open Access article under the terms of the Creative Commons Attribution License (<http://creativecommons.org/licenses/by/4.0>). Please note that the reuse, redistribution and reproduction in particular requires that the authors and source are credited.

The license is subject to the *Beilstein Journal of Organic Chemistry* terms and conditions: (<https://www.beilstein-journals.org/bjoc>)

The definitive version of this article is the electronic one which can be found at:  
[doi:10.3762/bjoc.15.88](https://doi.org/10.3762/bjoc.15.88)



# Novel (2-amino-4-arylimidazolyl)propanoic acids and pyrrolo[1,2-*c*]imidazoles via the domino reactions of 2-amino-4-arylimidazoles with carbonyl and methylene active compounds

Victoria V. Lipson<sup>\*1,2,3</sup>, Tetiana L. Pavlovska<sup>1,3</sup>, Nataliya V. Svetlichnaya<sup>2</sup>, Anna A. Poryvai<sup>3</sup>, Nikolay Yu. Gorobets<sup>1</sup>, Erik V. Van der Eycken<sup>4,5</sup>, Irina S. Konovalova<sup>1</sup>, Svetlana V. Shiskina<sup>1,3</sup>, Alexander V. Borisov<sup>6</sup>, Vladimir I. Musatov<sup>1</sup> and Alexander V. Mazepa<sup>7</sup>

## Full Research Paper

Open Access

### Address:

<sup>1</sup>SSI "Institute for Single Crystals" of National Academy of Sciences of Ukraine, Nauky Ave. 60, Kharkiv 61074, Ukraine, <sup>2</sup>Antidiabetic Drug Laboratory, SI "V.Ya. Danilevsky Institute for Endocrine Pathology Problems", Academy of Medical Sciences of Ukraine, 10, Alchevskikh St., Kharkiv 61002, Ukraine, <sup>3</sup>Chemistry Department, V.N. Karazin Kharkov National University, Kharkov 61022, Ukraine, <sup>4</sup>Laboratory for Organic & Microwave-Assisted Chemistry (LOMAC), Katholieke Universiteit Leuven, Celestijnenlaan 200F, B-3001 Leuven, Belgium, <sup>5</sup>Peoples' Friendship University of Russia (RUDN University) 6 Miklukho-Maklaya street, Moscow, 117198, Russia, <sup>6</sup>Enamine Ltd., 23 Chervonotkats'ka str., Kyiv 01003, Ukraine and <sup>7</sup>A.V. Bogatsky physico-chemical institute of the National Academy of Sciences of Ukraine, 86, Lustdorskaya doroga, 65080, Odessa, Ukraine

### Email:

Victoria V. Lipson<sup>\*</sup> - lipson@ukr.net

<sup>\*</sup> Corresponding author

### Keywords:

2-amino-4-arylimidazole; (2-amino-4-arylimidazolyl)propanoic acid; isatin; Meldrum's acid; multicomponent reactions; pyrrolo[1,2-*c*]imidazole; 3,3'-spirooxindoles

*Beilstein J. Org. Chem.* **2019**, *15*, 1032–1045.

doi:10.3762/bjoc.15.101

Received: 24 February 2019

Accepted: 18 April 2019

Published: 06 May 2019

This article is part of the thematic issue "Multicomponent reactions III".

Guest Editor: T. J. J. Müller

© 2019 Lipson et al.; licensee Beilstein-Institut.

License and terms: see end of document.

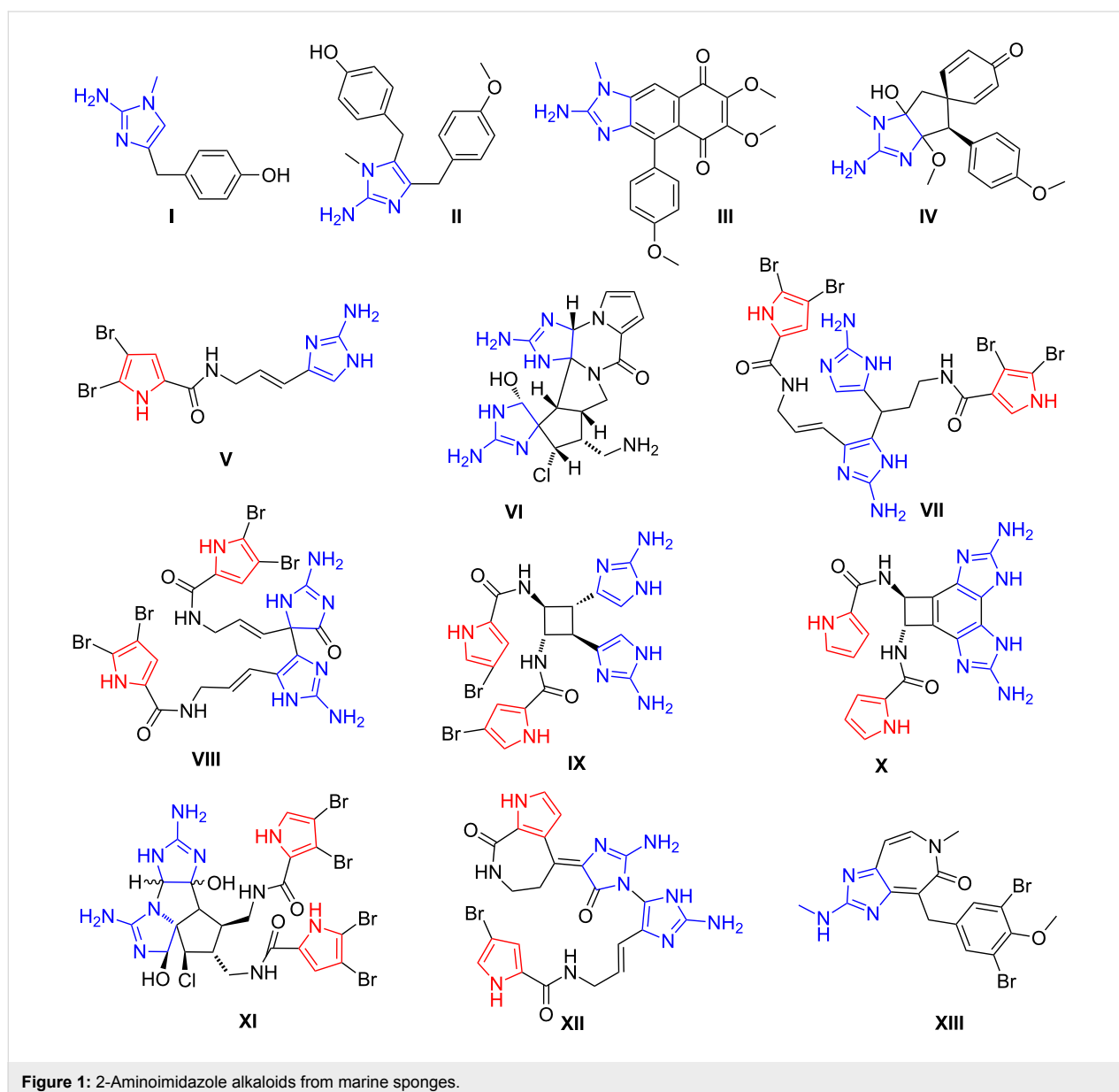
## Abstract

The unexpectedly uncatalyzed reaction between 2-amino-4-arylimidazoles, aromatic aldehydes and Meldrum's acid has selectively led to the corresponding Knoevenagel–Michael adducts containing a free amino group in the imidazole fragment. The adducts derived from Meldrum's acid have been smoothly converted into 1,7-diaryl-3-amino-6,7-dihydro-5*H*-pyrrolo[1,2-*c*]imidazol-5-ones and 3-(2-amino-4-aryl-1*H*-imidazol-5-yl)-3-arylpropanoic acids. The interaction of 2-amino-4-arylimidazoles with aromatic aldehydes or isatins and acyclic methylene active compounds has led to the formation of pyrrolo[1,2-*c*]imidazole-6-carbonitriles, pyrrolo[1,2-*c*]imidazole-6-carboxylates and spiro[indoline-3,7'-pyrrolo[1,2-*c*]imidazoles], which can be considered as the analogues of both 3,3'-spirooxindole and 2-aminoimidazole marine sponge alkaloids.

## Introduction

Heterocyclic compounds of both natural and synthetic origin, containing in their structure pyrrole and imidazole rings, display a wide set of pharmacologically significant activities. The most important natural sources of such systems are marine sponges. Since the 70's of 20th century up to date more than 150 derivatives containing pyrrole and 2-aminoimidazole fragments in their structure were found among the metabolites of these marine organisms [1]. This group of compounds is characterized by an exceptional molecular diversity. The main structural types of these substances are shown in Figure 1. The metabolites of *Leucetta Sp.* and *Clathrina Sp.* are presented by achiral imidazole alkaloids from the group of benzyl substituted 2-aminoimidazole (dorimidazole A (**I**), naamine A (**II**)), fused

cyclic systems (2-amino-2-deoxykealiquinone (**III**)) and spiro-linked compounds ((-)-spirocalcaridine B (**IV**)) [2]. *Agelas Sp.* are a source of alkaloids with core structures containing simultaneously pyrrole carboxamide and 2-aminoimidazole moieties such as the simple achiral compound oroidine (**V**) and spatially organized molecules in a complex manner with a large number of chiral centres like (-)-palau'amine (**VI**) [3]. Oroidine (**V**) and other related vinyl 2-aminoimidazoles of this class are monomeric precursors of nagelamide A (**VII**), mauritamine (**VIII**), sceptrin (**IX**), benzosceptrin A (**X**), axinellamines (**XI**) and stylissazole A (**XII**) alkaloids [1,4,5]. Fused 2-aminoimidazole and azeponone derivatives **XIII** were isolated recently from an extract of *Pseudoceratina Sp.* [6].



**Figure 1:** 2-Aminoimidazole alkaloids from marine sponges.

The variety of types of pharmacological activity revealed in these marine sponges' metabolites is not inferior to the chemodiversity of their structure. Many of them are reported to have properties such as  $\alpha$ -adrenoreceptors [7] and leukotriene B4 receptor antagonists [8], cyclin-dependent kinases GSK-3 $\beta$ , CK1 [9] and nitric oxide synthase activity inhibitors [10,11], as well as antibacterial [2], antifungal [12], antihistamine [13] and antitumor activities [14]. Remarkable immunosuppressive properties are inherent to palau'amine (**VI**) [15]. Ceratamines **XIII** are the disruptors of microtubule dynamics, therefore are of great interest in cancer drug discovery [6]. Thereby, the stereo-controlled total synthesis of marine alkaloids such as axinellamines [16] and the search of new 2-aminoimidazole and pyrrole containing compounds with a core structure that mimics metabolites of marine sponges with interesting biological properties has received considerable attention from both chemists and pharmacologists.

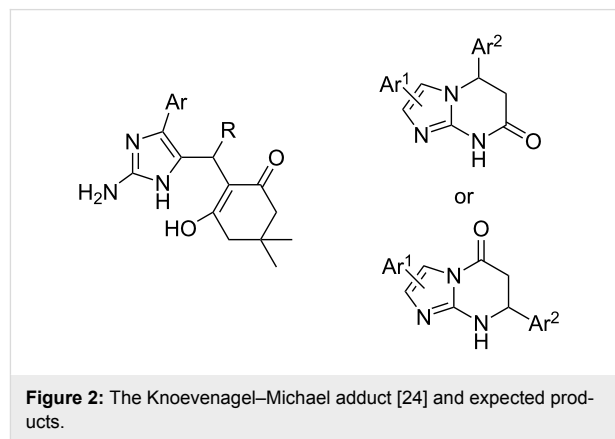
In the middle of 2000s, the authors of the studies [17–19] proposed a facile one-pot two-step procedure for the synthesis of diversely substituted 2-aminoimidazoles from  $\alpha$ -bromocarbonyl compounds and substituted 2-aminopyrimidines. This methodology allowed the rapid synthesis of alkaloids of the isonaamine series [20] and other polysubstituted 2-aminoimidazoles with moderate cytostatic activity [21] and biofilm inhibitory activity against *S. Typhimurium* and *P. Aeruginosa* [22,23].

We have used 4-aryl-substituted 2-aminoimidazoles described by the authors of the aforementioned works as polyfunctional building blocks for the formation of different fused and spiro-linked heterocyclic systems. Last ones are able to act as precursors in the synthesis of the substances that mimic the core structure of marine alkaloids due to the presence of several reaction centres, which allow their further chemical modification. In the present work we disclose our results on the multicomponent reactions between 2-amino-4-arylimidazoles, aromatic aldehydes or isatins and cyclic or acyclic CH acids. As the last compounds we have used Meldrum's acid, malononitrile and ethyl 2-cyanoacetate.

## Results and Discussion

In view of the structure of 2-amino-4-arylimidazoles containing four nonequivalent nucleophilic centres several pathways can be assumed for their reactions with carbonyl 1,3-bielectrophiles or their synthetic precursors in the case of three-component reactions between these amines, carbonyl compounds and CH acids. Previously, an unusual direction of the three-component reaction between 2-aminoimidazoles, aldehydes and 5,5-dimethyl-1,3-cyclohexanedione has led to the formation of the Knoevenagel–Michael adducts (Figure 2) [24]. By analogy with

our results obtained with the use of other aminoazoles in the reactions with benzaldehydes and Meldrum's acid [25] we expected the formation of one or several isomers of tetrahydroimidazopyrimidinone derivatives (Figure 2).

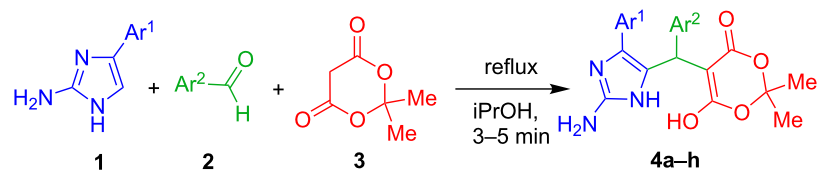


However, a short time (3–5 min) and reflux of the equimolar amounts of amines **1**, *para*-substituted benzaldehydes **2**, and Meldrum's acid **3** in 2-propanol led to Knoevenagel–Michael adducts **4a–h** (Table 1).

Beside the short reaction times and mild conditions, this catalyst-free three-component condensation is characterized by a very facile performance since the solid products are formed as precipitates and are simply isolated in good yields without any additional purification (Table 1). In our synthetic practice this is the first example of the existence of stable  $\beta$ -adducts, which simultaneously contain Meldrum's acid and aminoazole fragments. In all earlier described experiments with participation of different  $\alpha$ -aminoazoles as binucleophiles the reaction cascade readily accomplished by the formation of fused heterocyclic systems [25].

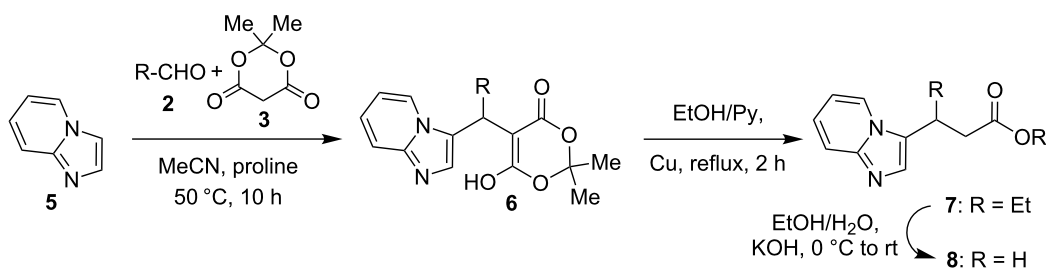
An analogous three-component reaction involving indole or imidazo[1,2-*a*]pyridine derivatives instead of 2-aminoimidazoles is referred in the literature as Yonemitsu reaction or Yonemitsu-like reaction [26–31]. The similar Michael-type adducts **6** were isolated [31] from the reaction of imidazo[1,2-*a*]pyridine with aldehydes and Meldrum's acid in acetonitrile in the presence of a catalytic amount of proline (Scheme 1) and then they were successfully converted to the appropriate esters **7** and acids **8**.

In our case, we have isolated products **4a–h** individually and characterized them by IR,  $^1\text{H}$ ,  $^{13}\text{C}$  NMR, and mass-spectral methods. The  $^1\text{H}$  NMR spectra of products **4** have two characteristic broad singlets that represent the exchangeable proton shifts of the crossed signals of NH and OH groups at

**Table 1:** Three-component condensation of 2-amino-4-arylimidazoles, aldehydes and Meldrum's acid.

Entry	Compound	Ar <sup>1</sup>	Ar <sup>2</sup>	Yield <sup>a</sup> , %
1	<b>4a</b>	Ph	Ph	77
2	<b>4b</b>	Ph	4-Me-C <sub>6</sub> H <sub>4</sub>	30
3	<b>4c</b>	4-Me-C <sub>6</sub> H <sub>4</sub>	Ph	48
4	<b>4d</b>	4-Me-C <sub>6</sub> H <sub>4</sub>	4-Me-C <sub>6</sub> H <sub>4</sub>	50
5	<b>4e</b>	4-Me-C <sub>6</sub> H <sub>4</sub>	4-NO <sub>2</sub> -C <sub>6</sub> H <sub>4</sub>	40
6	<b>4f</b>	4-F-C <sub>6</sub> H <sub>4</sub>	Ph	54
7	<b>4g</b>	4-F-C <sub>6</sub> H <sub>4</sub>	4-Me-C <sub>6</sub> H <sub>4</sub>	50
8	<b>4h</b>	4-Me-C <sub>6</sub> H <sub>4</sub>	3-OH-4-OMe-C <sub>6</sub> H <sub>4</sub>	70

<sup>a</sup>The isolated yields accounted on the quantities of the starting materials 1–3.

**Scheme 1:** The three component condensation of imidazo[1,2-*a*]pyridine, aldehydes and Meldrum's acid described by Gerencsér et al. [31].

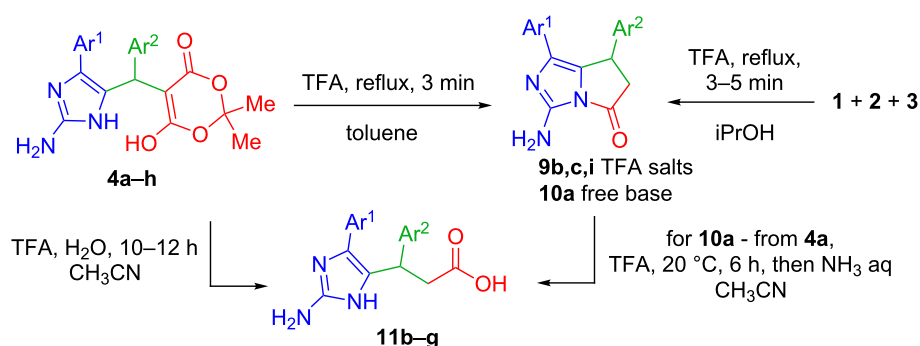
12.35–11.61 ppm and the NH<sub>2</sub> group of the aminoimidazole fragment at 7.47–7.26 ppm, as well as a singlet for the protons of two methyl groups. The existence of the dioxanedione cycle in enol form is proven by the presence of the singlet of a methyne proton near the saturated carbon atom at 5.42–5.56 ppm and the absence of the signal for the methyne proton of the dioxanedione cycle. With regard to the mass spectra, all compounds **4** exhibit similar behaviour in their fragmentation, showing the absence of the molecular ion peak and the presence of intense signals that occur due to cleavage of acetone and CO<sub>2</sub> molecules from the dioxanedione moieties.

Their further transformation took place in the presence of the catalytic amounts of TFA in toluene under short time reflux (3 min) or addition of the catalytic amounts of TFA to the initial three-component mixture (Table 2).

The reaction proceeded via 1,3-dioxanedione cycle cleavage followed by elimination of acetone and CO<sub>2</sub> to provide novel

pyrrolo[1,2-*c*]imidazol-5-ones trifluoroacetates **9b,c,i** precipitated from the reaction mixture (Table 2). The corresponding bicyclic amine **10a** was obtained by the prolonged treatment of the product **4a** with catalytic amounts of TFA in acetonitrile followed by the addition of an aqueous solution of NH<sub>3</sub>.

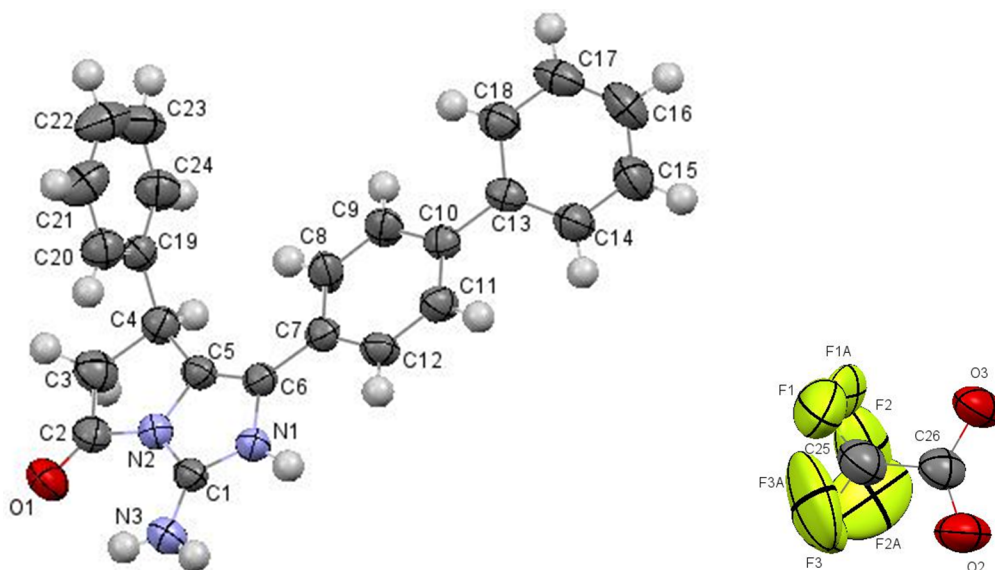
The structures of cyclized products **9** and **10** were confirmed by spectral methods. The signals of NH, OH and methyl groups of the dioxanedione cycle are absent in the <sup>1</sup>H NMR spectra of trifluoroacetates **9**. The broad signal of the NH<sub>2</sub> group shifts to the downfield signal of NH<sub>3</sub><sup>+</sup> at 8.5–8.2 ppm. Protons of the CH<sub>2</sub>–CH fragment in the pyrrolidine cycle show the shifts of an ABX system for CH<sub>X</sub> at 4.73–4.85, CH<sub>B</sub> at 3.81–3.84, CH<sub>A</sub> at 2.86–2.95 ppm. The same situation is observed for compound **10a**, however, the signal of the free NH<sub>2</sub> group of the aminoimidazole moiety shifts to 6.36 ppm. The common feature of the mass spectra of salts **9** is the absence of the salt molecular ion peak and the presence of the intense signals that occur due to cleavage of the CF<sub>3</sub>COO<sup>−</sup> anion.

**Table 2:** Synthesis of compounds **9b,c,i**, **10a**, **11b–g**.

Entry	Compound	Ar <sup>1</sup>	Ar <sup>2</sup>	Yield, %
1	<b>9b</b>	Ph	4-Me-C <sub>6</sub> H <sub>4</sub>	52
2	<b>9c</b>	4-Me-C <sub>6</sub> H <sub>4</sub>	Ph	60
3	<b>9i</b>	4-Ph-C <sub>6</sub> H <sub>4</sub>	Ph	71
4	<b>10a</b>	Ph	Ph	68
5	<b>11b</b>	Ph	4-Me-C <sub>6</sub> H <sub>4</sub>	55
6	<b>11c</b>	4-Me-C <sub>6</sub> H <sub>4</sub>	Ph	76
7	<b>11d</b>	4-Me-C <sub>6</sub> H <sub>4</sub>	4-Me-C <sub>6</sub> H <sub>4</sub>	65
8	<b>11e</b>	4-Me-C <sub>6</sub> H <sub>4</sub>	4-NO <sub>2</sub> -C <sub>6</sub> H <sub>4</sub>	60
9	<b>11f</b>	4-F-C <sub>6</sub> H <sub>4</sub>	Ph	67
10	<b>11g</b>	4-F-C <sub>6</sub> H <sub>4</sub>	4-Me-C <sub>6</sub> H <sub>4</sub>	85

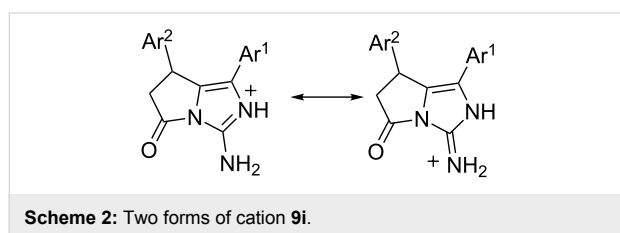
Single crystal X-ray diffraction analysis of biphenyl compound **9i** has finally proved the structures of the obtained products (Figure 3).

Compound **9i** exists as organic salt with trifluoroacetic acid in the crystal phase. The existence of the trifluoroacetic molecule as anion is confirmed by close values of the C–O bond lengths



**Figure 3:** Molecular structure of 1-([1,1'-biphenyl]-4-yl)-5-oxo-7-phenyl-6,7-dihydro-5H-pyrrolo[1,2-c]imidazol-3-aminium 2,2,2-trifluoroacetate **9i** according to X-ray diffraction data. Thermal ellipsoids of atoms are shown at 50% probability level.

(1.229(2) Å and 1.238(2) Å, respectively) and the absence of the hydrogen atom at the carboxylic group. The analysis of the bond lengths in the imidazole ring has revealed that the C1–N1 and C1–N3 bonds are equal (1.320(3) Å and 1.320(2) Å, respectively) and the N1–C6 bond (1.414(6) Å) is slightly elongated as compare to its mean value 1.376 Å [32]. The hydrogen atoms at the N1 and N3 were located from the electron density difference maps. As a result we may describe the structure of the organic cation as superposition of two forms (Scheme 2).



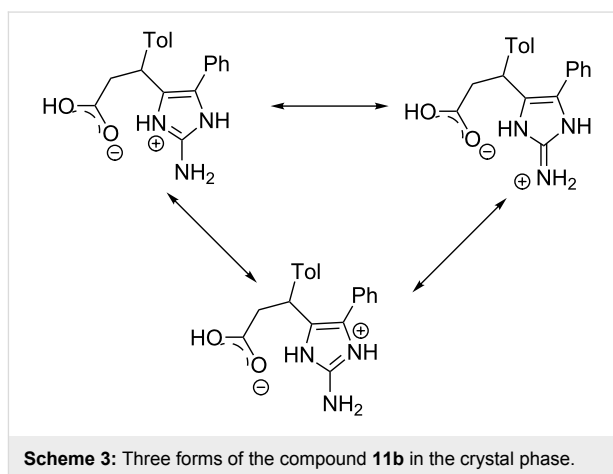
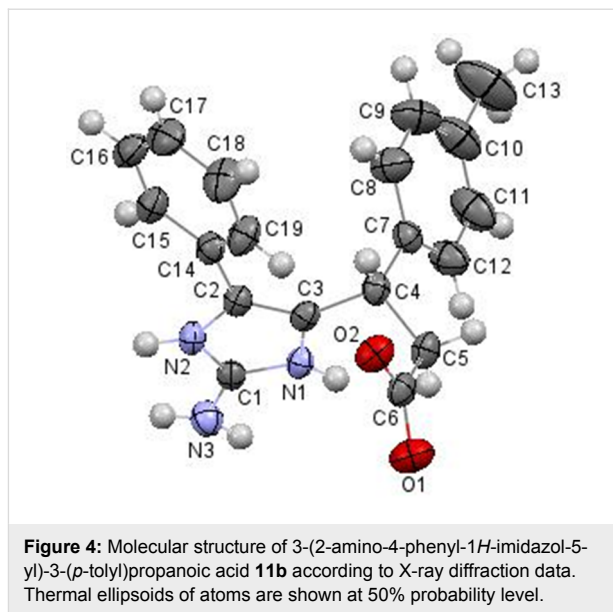
The prolonged reflux (10 h) of compounds **4b–g** in acetonitrile in the presence of a catalytic amount of TFA leads to the opening of the pyrrolidone ring followed by the formation of acids **11b–g** (Table 2). The process remarkably accelerates while adding water to the reaction mixture. The acids **11** can also be obtained from pyrrolo[1,2-*c*]imidazol-3-aminium trifluoroacetates **9** after prolonged reflux (12 h) in aqueous acetonitrile.

The <sup>1</sup>H NMR spectra of acids **11** contain the signals of the protons of the aromatic system, the broad singlet for NH<sub>2</sub> group at 5.87–5.82 ppm and the signals of the ABX protons of the propionyl fragment –CH<sub>X</sub> at 4.60–4.30 ppm and CH<sub>2AB</sub> at 3.00–2.60 ppm.

Finally, the structure of acids **11** was confirmed by X-ray diffraction data of the sample compound **11b** (Figure 4).

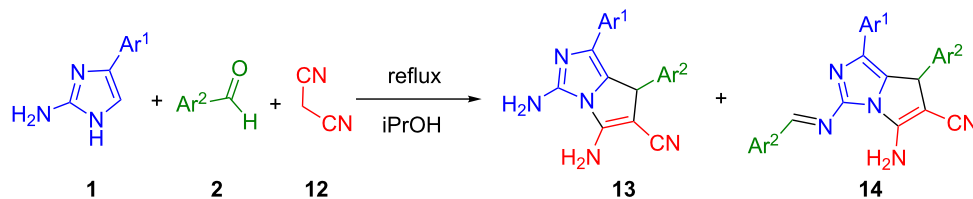
Compound **11b** was found to be a zwitterion and exists as monohydrate in the crystal phase. The absence of the hydrogen atom and equalization of the C6–O1 and C6–O2 bond lengths (1.254(2) Å and 1.259(2) Å, respectively) allow presuming the location of the negative charge at the deprotonated carboxylic group. The very close lengths of the bonds centred at the C1 atom (the N2–C1 bond length is 1.332(2) Å, the C1–N3 bond length is 1.337(3) Å and the N1–C1 bond length is 1.340(2) Å) allows to describe the zwitterion as superposition of three forms with different location of the positive charge (Scheme 3).

Literatur data concerning pyrrolo[1,2-*c*]imidazol-5-ones is quite limited and the known 6,7-dihydro analogs are represented only by several substances [33,34]. Partially hydrogenated pyrrolo[1,2-*c*]imidazole is a part of (±)-axinellamines **11**.



4-[(5*R*)-6,7-Dihydro-5*H*-pyrrolo[1,2-*c*]imidazol-5-yl]-3-fluorobenzonitrile (LCI-699, osilodrostat) is considered as an inhibitor of aldosterone synthase (CYP11B2) and 11β-hydroxylase (CYP11B1), which is responsible for cortisol production [35]. This compound is under development for the treatment of Cushing's syndrome and pituitary ACTH hypersecretion [36]. From this point of view the approach to pyrrolo[1,2-*c*]imidazole moiety by using acyclic methylene active compounds, that can lead to cyclic products, has a high potential for diversity-oriented synthesis.

In the three-component condensations of equimolar amounts of 2-amino-4-arylimidazoles **1**, *para*-substituted benzaldehydes **2** and malononitrile (**12**) in 2-propanol the Knoevenagel–Michael adduct was not obtained. The reaction was complete to form a mixture of pyrrolo[1,2-*c*]imidazol-6-carbonitriles **13** and their azomethine derivatives **14** (Scheme 4).



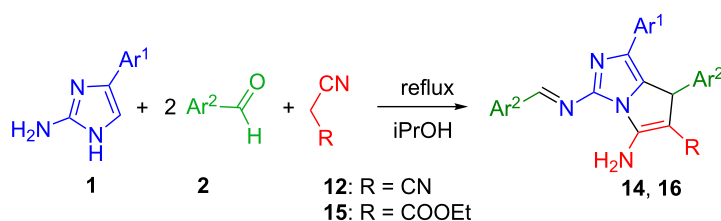
**Scheme 4:** Synthesis of the mixture of compounds **13** and **14**.

The use of a double excess of aromatic aldehydes **2** in this condensation prevented the formation of a mixture of substances and led to the formation of individual 5-amino-3-(arylideneamino)-1-aryl-7-aryl-7H-pyrrolo[1,2-c]imidazole-6-carbonitriles **14**, as well as azomethines **16** in case of using ethyl 2-cyanoacetate **15** as the acyclic methylene active compound (Table 3).

The isolated products **14a–f** and **16a,b** were characterized by IR,  $^1\text{H}$ ,  $^{13}\text{C}$  NMR and mass-spectral methods. The mass spectra of compounds **14** and **16** show the similar type of fragmentation. They contain peaks of molecular ions, as well as signals corresponding to the loss of fragments  $[\text{M}^{+\bullet} - \text{NH}_2, - \text{CN}]$ ,  $[\text{M}^{+\bullet} - \text{ArCHN}]$ ,  $[\text{M}^{+\bullet} - \text{NH}_2, - \text{CN}, - \text{CAr}]$ . From the comparison of these data with the results of elemental analysis, it follows that in the formation of condensed systems **14** with the participation of two molecules of aromatic aldehydes two molecules of water were cleaved. In the IR spectra, the most characteristic bands represent the absorption of  $\text{NH}_2$  groups at  $3420$  and  $3332\text{ cm}^{-1}$  and the nitril group  $\text{CN}$  at  $2250\text{ cm}^{-1}$ . In addition, there are characteristic bands at  $1664$ – $1668\text{ cm}^{-1}$ , which

may include both  $\text{C}=\text{C}$  bond and the exocyclic  $\text{C}=\text{N}$  bond. Fluctuations of endocyclic  $\text{C}=\text{N}$  fragments are observed at  $1584\text{ cm}^{-1}$ . Thus, at least one nitrile and one  $\text{NH}_2$  group are present in the obtained compounds. The  $^1\text{H}$  NMR spectra of compounds **14** along with protons of aryl substituents contain the characteristic singlet of the azomethine fragment at  $9.24$ – $9.34\text{ ppm}$  and a singlet of the methyne proton  $\text{C}^7\text{H}$  at  $5.26$ – $5.36\text{ ppm}$ . Formation of the azomethine fragment during the interaction of the second molecule of the aromatic aldehyde with the  $\text{C}^2$ - $\text{NH}_2$  group of the imidazole moiety is confirmed by the disappearance of the singlet at  $5.17$ – $5.26\text{ ppm}$ , which is inherent to the  $\text{NH}_2$  group at the  $\text{C}^2$  position of the imidazole ring. Instead, in the spectra, a broad singlet of the  $\text{C}^5$ - $\text{NH}_2$  group of the imidazo[1,2-*c*]pyrrole cycle appears at  $7.55$ – $7.63\text{ ppm}$ . The absence in  $^1\text{H}$  NMR spectra of the signal of the  $\text{CH}$  of proton of the imidazole cycle at  $6.97$ – $7.10\text{ ppm}$  shows that the reaction takes place in the  $\text{C}^5$  nucleophilic centre of the aminoazole. The  $^1\text{H}$  NMR spectra of compounds **16** show the resonance of the ethyl group of the ethyl 2-cyanoacetate substituent as a triplet of a  $\text{CH}_3$  group at  $1.02\text{ ppm}$ ,  $J = 7.02\text{ Hz}$  and multiplets of the  $\text{CH}_2$  group at  $3.85$ – $4.03\text{ ppm}$ . The

**Table 3:** Synthesis of compounds **14** and **16**.

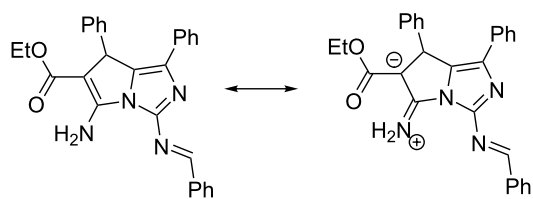


Entry	Compound	Ar <sup>1</sup>	Ar <sup>2</sup>	Yield, %
1	<b>14a</b>	Ph	4-Me-C <sub>6</sub> H <sub>4</sub>	65
2	<b>14b</b>	4-Cl-C <sub>6</sub> H <sub>4</sub>	Ph	83
3	<b>14c</b>	4-OMe-C <sub>6</sub> H <sub>4</sub>	Ph	45
4	<b>14d</b>	Ph	4-Br-C <sub>6</sub> H <sub>4</sub>	40
5	<b>14e</b>	Ph	4-F-C <sub>6</sub> H <sub>4</sub>	58
7	<b>14f</b>	4-Me-C <sub>6</sub> H <sub>4</sub>	4-Br-C <sub>6</sub> H <sub>4</sub>	59
8	<b>16a</b>	Ph	Ph	30
9	<b>16b</b>	Ph	4-Br-C <sub>6</sub> H <sub>4</sub>	40

$^1\text{H}$  NMR spectra of derivatives **16** are similar with the spectra of compounds **14** by the absence of the resonance of the  $\text{NH}_2$  group and methyne proton of the aminoimidazole ring, which allows to classify them as compounds of the same type containing a fused aminoimidazo[1,2-*c*]pyrrole moiety.

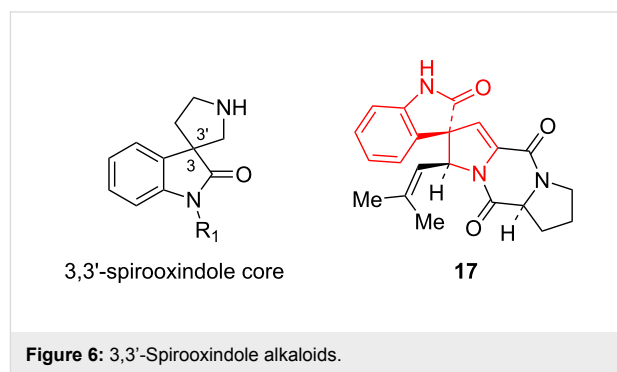
Finally, the structure of azomethines **16** was confirmed by X-ray diffraction data of the sample compound **16a** (Figure 5).

All atoms of the bicyclic fragment lie in the plane within 0.01 Å. The analysis of the bond lengths has shown that the formally single exocyclic C1–N3 bond is shorter than the double endocyclic C6–C1 bond (1.336(6) Å and 1.354(9) Å, respectively). The C1 and C6 atoms are planar indicating their  $\text{sp}^2$  hybridization. Such a distribution of electron density allows to discuss the zwitter-ionic form and to consider the structure of **16a** as superposition of two resonance structures (Scheme 5).



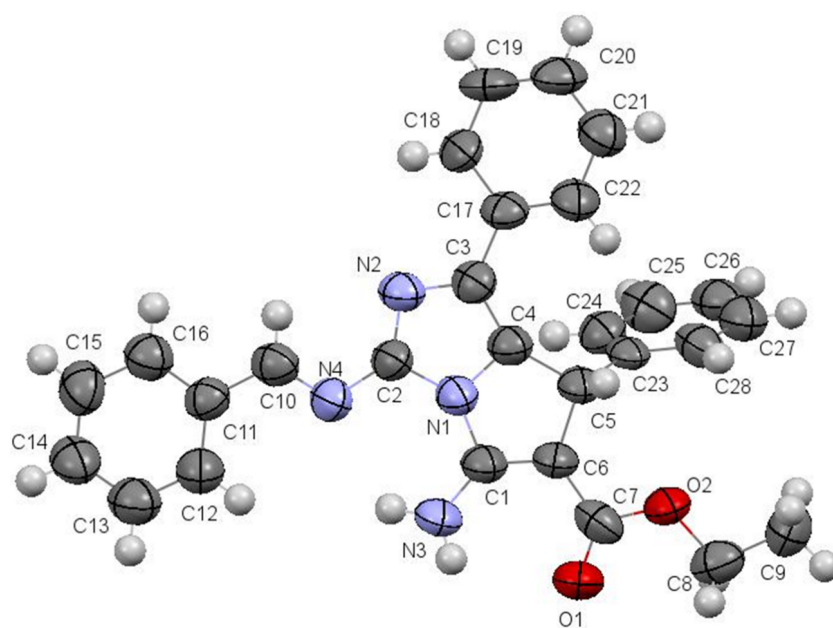
**Scheme 5:** Resonance structures of **16a**.

In the next step of our research we have involved isatin **18** as the compound bearing a carbonyl group, as well in this case the pyrrolo[1,2-*c*]imidazole moiety will be spiro-fused with the oxindole moiety, and the resulting structures can be considered as analogues of 3,3'-spirooxindole alkaloids, such as spirotryprostatin B (**17**, Figure 6) [37].

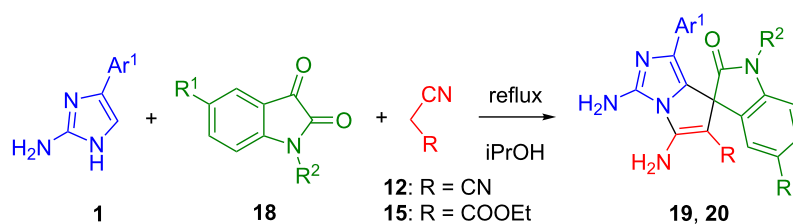


**Figure 6:** 3,3'-Spirooxindole alkaloids.

Indeed, the equimolar three-component reactions with the participation of 2-amino-4-arylimidazoles **1**, isatins **18** and acyclic methylene active compounds **12** and **15** have completed with the formation of spirooxindoles **19a–h** and **20a–c**, respectively, with moderate to high yields (Table 4). The reduced reactivity of the carbonyl group of isatins compared with benzaldehydes, and the greater stability of their Knoevenagel adducts leads to the formation of individual spiro compounds, not to a mixture



**Figure 5:** Molecular structure of aminoimidazo[1,2-*c*]pyrrole **16a** according to X-ray diffraction data. Thermal ellipsoids of atoms are shown at 50% probability level.

**Table 4:** Synthesis of spirooxindoles **19** and **20**.

Entry	Compound	Ar <sup>1</sup>	R <sup>1</sup>	R <sup>2</sup>	Yield, %
1	<b>19a</b>	Ph	H	Me	60
2	<b>19b</b>	Ph	Br	Me	68
3	<b>19c</b>	Ph	Me	Me	60
4	<b>19d</b>	Ph	F	4-ClC <sub>6</sub> H <sub>4</sub> CH <sub>2</sub>	40
5	<b>19e</b>	4-Me-C <sub>6</sub> H <sub>4</sub>	H	Me	68
7	<b>19f</b>	4-Me-C <sub>6</sub> H <sub>4</sub>	Br	Me	65
8	<b>19g</b>	4-F-C <sub>6</sub> H <sub>4</sub>	Br	Me	40
9	<b>19h</b>	4-Me-C <sub>6</sub> H <sub>4</sub>	Cl	Me	48
10	<b>20a</b>	Ph	H	Me	72
11	<b>20b</b>	4-OMe-C <sub>6</sub> H <sub>4</sub>	Br	Me	43
12	<b>20c</b>	4-Me-C <sub>6</sub> H <sub>4</sub>	Br	Me	60

of substances. However, condensations with the use of N-unsubstituted isatins are accompanied by the resinification of the reaction mixture, which may be caused by competing reactions of heterocyclization of the mentioned Knoevenagel adducts. In similar reactions described in the literature [38–40], the authors recognized the importance of protecting the amide fragment of isatin, since it affects the reactivity and, in some cases, the enantioselectivity of processes. In order to prevent undesirable side reactions in the future, three-component condensations were carried out using N-substituted isatins.

The isolated products **19a–h** and **20a–c** were characterized by IR, <sup>1</sup>H, <sup>13</sup>C NMR and mass-spectral methods. The <sup>1</sup>H NMR spectra of spirooxindoles **19a–h** and **20a–c**, along with protons of aryl substituents of imidazole and isatin contain a broad singlet with 2H intensity of the C<sup>5</sup>–NH<sub>2</sub> group of the imidazo[1,2-*c*]pyrrole cycle at 7.74–7.84 ppm. A characteristic feature is the appearance of another broad singlet at the 6.37–6.46 ppm, inherent to the amino group of the C<sup>2</sup> atom of the imidazole ring, whose chemical shift is affected by the character of the substituents in 2-amino-4-arylimidazoles. The multiplets of the C<sup>6</sup>-ethoxy group of the compounds **20a–c** are seen at 0.62–0.88 (OCH<sub>2</sub>CH<sub>3</sub>) and 3.57–3.85 ppm (OCH<sub>2</sub>CH<sub>3</sub>). The <sup>13</sup>C NMR spectra of spirooxindoles **19a–h** and **20a–c** are represented by the groups of singlets at the 66.86–69.83 and 152.29–154.72 ppm. The signal of the spiro atom is seen as a singlet at 53.53–56.03 ppm. Signals of the carbon atoms of the imidazole ring are located in the resonance region of the carbon

atoms of the aryl substituents. Taken together, these data indicate the formation of the pyrrolo[1,2-*c*]imidazole cyclic system.

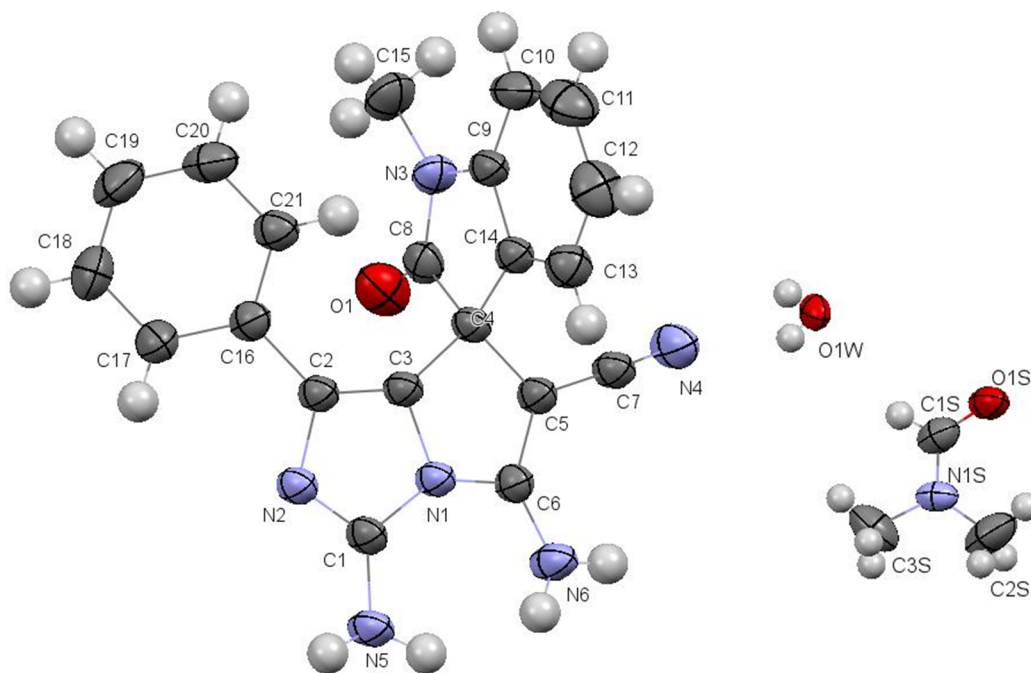
Finally, the structures of spirooxindoles **19** and **20** were confirmed by X-ray diffraction data of the sample compound **19a** (Figure 7).

Compound **19a** exists in the crystal phase as solvate with dimethylformamide and water in a 1:1:1 ratio.

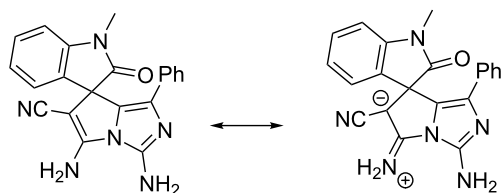
The spiro-joined bicyclic fragments are turned relatively to each other in such a way that the dihedral angle between mean planes of the bicycles is 84.5°. The analysis of the bond lengths has shown that the formally single exocyclic C6–N6 bond is significantly shorter than the double endocyclic C6–C5 bond (1.319(2) Å and 1.373(3) Å, respectively). The C1 and C6 atoms are planar indicating their sp<sup>2</sup> hybridization. Such a distribution of electron density allows discussing the zwitter-ionic form and considering the structure of **19a** as superposition of two resonance structures similar to **16a** (Scheme 6).

## Conclusion

In the described three-component reactions with aldehydes or isatins and cyclic or acyclic CH acids the C<sup>5</sup> reaction centre in the 2-amino-4-arylimidazoles possesses higher nucleophilicity than both the exo- and endocyclic amino groups. Regarding the short reaction times of novel Yonemitsu-type reactions that has been achieved without application of any catalyst we assume



**Figure 7:** Molecular structure of aminoimidazo[1,2-*c*]pyrrole **19a** according to X-ray diffraction data. Thermal ellipsoids of atoms are shown at 50% probability level.



**Scheme 6:** Resonance structures of **19a**.

that 2-amino-4-arylimidazoles are more reactive substrates for these syntheses leading to the stable Michael-type adducts with aldehydes and Meldrum's acid than the previously investigated indole and imidazo[1,2-*a*]pyridine. Moreover, as it has been shown that their further transformations may result in the formation of both unexplored heterocyclic systems containing a free amino group open for chemical modifications and the corresponding hetarylpropanoic acids providing useful templates for the synthesis of some marine alkaloids or their analogues.

In domino reactions of the 2-amino-4-arylimidazoles with isatins and aliphatic CH acids stable Michael adducts have not been fixed. Cyclocondensation has readily led to the formation of 6'-substituted 3',5'-diamino-1-alkyl-2-oxo-1'-aryl-spiro[indolin-3,7'-pyrrolo[1,2-*c*]imidazoles], which can be considered as the analogues of alkaloids with both pyrrolo[1,2-

*c*]imidazol and 3,3'-spiroindole fragments in the core structure.

## Experimental

**Reagents and analytics:** Starting materials were purchased from commercial suppliers. Melting points were determined on a Kofler apparatus and temperatures were not corrected. The IR spectra were recorded in KBr on a Specord M-82 spectrometer. The  $^1\text{H}$  NMR spectra were measured on a Varian Mercury VX-200 (200 MHz) and Bruker AM-400 spectrometer (400 MHz),  $^{13}\text{C}$  NMR spectra were measured on a Bruker AM-400 (100 MHz) and Bruker Avance DRX 500 (125 MHz) spectrometers in  $\text{DMSO-}d_6$ ,  $\text{CDCl}_3$  and trifluoroacetic acid (TFA) using TMS as internal standard. The mass spectra were recorded on a Varian 1200L GC-MS instrument, ionization by EI at 70 eV. Fast atom bombardment (FAB) mass spectrometry was performed on a VG 70-70EQ mass spectrometer, equipped with an argon primary atom beam, and a *m*-nitrobenzyl alcohol matrix was used. LC-MS experiments were performed on an Applied Biosystems (Shimadzu 10-AV LC, Gilson-215 automatic giving, mass spectrometer API 150EX, detectors UV (215 and 254 nm), and ELS, column Luna-C18, Phenomenex, 5  $\mu$ , 100 Angstrom, 150  $\times$  2 mm RP). Elemental analyses were made on an elemental analyzer Euro AE-3000. The progress of reactions and the purity of the obtained compounds were monitored by TLC on Silufol UV-254 plates in  $\text{EtOAc}/\text{CH}_2\text{Cl}_2$  (1:4) and visualized under UV light or iodine fume.

**General procedure for the synthesis of 5-((2-amino-4-aryl-1*H*-imidazol-5-yl)(aryl)methyl)-6-hydroxy-2,2-dimethyl-4*H*-1,3-dioxin-4-ones:**

An equimolar mixture (1.0 mmol) of the corresponding 2-amino-4-arylimidazole **1**, aromatic aldehyde **2** and Meldrum's acid **3** was refluxed in *i*PrOH (3 mL) for 3–5 min. After cooling, the solid products **4** were filtered off, washed with *i*PrOH and dried on air. **4a**: colourless solid, 77%; mp 243–245 °C; IR (KBr,  $\text{cm}^{-1}$ ): 3404–2800 ( $\text{NH}_2$ , NH, OH), 1684 (C=O);  $^1\text{H}$  NMR (200 MHz,  $\text{DMSO-}d_6$ )  $\delta$  12.27 (br s, 2H, NH, OH), 7.61–7.49 (m, 2H,  $\text{H}_{\text{arom}}$ ), 7.48–7.31 (m, 5H,  $\text{H}_{\text{arom}}$ ), 7.27–7.01 (m, 5H,  $\text{NH}_2$ ,  $\text{H}_{\text{arom}}$ ), 5.48 (s, 1H, CH), 1.51 (s, 6H,  $\text{CH}_3$ );  $^{13}\text{C}$  NMR (125 MHz,  $\text{CDCl}_3$ )  $\delta$  166.8 (C=O), 146.6 (C-OH), 144.0, 129.4, 128.9, 128.4, 128.3, 127.5, 127.4, 127.2, 125.9, 121.1, 100.6, 76.0 (C=COH), 35.1 (CH), 26.4 ( $\text{CH}_3$ ), 25.9 ( $\text{CH}_3$ ); MS ( $m/z$ ) (%): 289 (76), (391 [ $\text{M}^+$ ] – 44 – 58), 247 (53), 159 (36), 104 (19), 77 (8), 44 (39), 43 (100); anal. calcd for  $\text{C}_{22}\text{H}_{21}\text{N}_3\text{O}_4$  (391.5) C, 67.52; H, 5.37; N, 10.74; found: C, 68.77; H, 5.93; N, 10.79.

**General procedure for the synthesis of 5-oxo-1,7-diaryl-6,7-dihydro-5*H*-pyrrolo[1,2-*c*]imidazol-3-aminium 2,2,2-trifluoroacetates:**

A mixture of the corresponding adduct **4** (0.1 mmol) and 0.08 mL (0.11 mmol) TFA was refluxed in 1 mL of toluene for 3 min. After cooling, 3 mL of *i*PrOH was added to the reaction mixture and the solid product **9** was filtered off, washed with *i*PrOH and dried on air. **9b**: colourless solid, 52%; mp 222–224 °C; IR (KBr,  $\text{cm}^{-1}$ ): 3432–3160 ( $\text{NH}_3^+$ ,  $\text{COO}^-$ ), 1782 (C=O);  $^1\text{H}$  NMR (400 MHz,  $\text{DMSO-}d_6$ )  $\delta$  8.54 (br s, 2H,  $\text{NH}_3^+$ ), 7.29–7.16 (m, 6H,  $\text{H}_{\text{arom}}$ ), 7.15–7.03 (m, 3H,  $\text{H}_{\text{arom}}$ ), 4.81 (d,  $J = 3.6$  Hz, 1H,  $\text{CH}_X$ ), 3.81 (dd,  $J_{\text{BX}} = 9.3$  Hz,  $J_{\text{AB}} = 18.6$  Hz, 1H,  $\text{CH}_B$ ), 2.91 (d,  $J_{\text{AX}} = 3.8$  Hz,  $J_{\text{AB}} = 18.7$  Hz, 1H,  $\text{CH}_A$ ), 2.20 (s, 3H,  $\text{CH}_3$ );  $^{13}\text{C}$  NMR (100 MHz,  $\text{DMSO-}d_6$ )  $\delta$  170.2 (C=O), 143.4, 137.7, 137.1, 129.9, 129.4, 129.2, 128.7, 128.4, 127.9, 125.8, 125.5, 46.2, 36.9, 21.1 ( $\text{CH}_3$ ); LC-MS: 304 (M –  $\text{CF}_3\text{COO}^-$ ), 305 (M –  $\text{CF}_3\text{COO}^- + \text{H}$ ).

**General procedure for the synthesis of 3-amino-1,7-diphenyl-6,7-dihydro-5*H*-pyrrolo[1,2-*c*]imidazol-5-one (10a):**

A mixture of the adduct **4a** (0.1 mmol) and 0.08 mL (0.11 mmol) of TFA was stirred in 2 mL of acetonitrile for 6 h, then conc. aqueous solution of  $\text{NH}_3$  was added to pH  $\approx$  8 and the solid product was filtered off, dried on air and crystallized from *i*PrOH. The title compound was obtained as a colourless solid (0.20 g, 68%); mp 198–200 °C; IR (KBr,  $\text{cm}^{-1}$ ): 3486–3100 ( $\text{NH}_2$ ), 1784 (C=O);  $^1\text{H}$  NMR (200 MHz,  $\text{DMSO-}d_6$ )  $\delta$  7.43–6.99 (m, 10H,  $\text{H}_{\text{arom}}$ ), 6.36 (br s, 2H,  $\text{NH}_2$ ), 4.75 (d,  $J = 2.9$  Hz, 1H,  $\text{CH}_X$ ), 3.83, (dd,  $J_{\text{BX}} = 9.2$  Hz,  $J_{\text{AB}} = 17.9$  Hz, 1H,  $\text{CH}_B$ ), 2.87 (d,  $J_{\text{AX}} = 3.3$  Hz,  $J_{\text{AB}} = 18.6$  Hz, 1H,  $\text{CH}_A$ );  $^{13}\text{C}$  NMR (125 MHz,  $\text{DMSO-}d_6$ )  $\delta$  169.6 (C=O), 143.9, 142.5, 133.8, 129.7, 129.4, 128.5, 127.8, 127.6, 127.5, 126.5, 125.4, 47.6, 36.9; MS ( $m/z$ ) (%): 289 (76) [ $\text{M}^+$ ], 247 (53), 159 (38),

104 (29), 77 (100), 44 (41), 43 (19); anal. calcd for  $\text{C}_{18}\text{H}_{15}\text{N}_3\text{O}$  (289.12) C, 74.74; H, 5.19; N, 14.53; found: C, 72.28; H, 6.79; N, 13.11.

**General procedure for the synthesis of 3-(2-amino-4-aryl-1*H*-imidazol-5-yl)-3-arylpropanoic acids:**

A mixture of the corresponding adduct **4** (0.1 mmol) and 0.08 mL (0.11 mmol) of TFA was stirred in 2 mL of aqueous acetonitrile for 10–12 h. After cooling, the solid products **11** were filtered off, washed with *i*PrOH and dried on air. **11b**: pale yellow solid, 55%; mp 282–285 °C;  $^1\text{H}$  NMR (200 MHz,  $\text{DMSO-}d_6$ )  $\delta$  7.38–7.23 (m, 4H,  $\text{H}_{\text{arom}}$ ), 7.22–6.98 (m, 5H,  $\text{H}_{\text{arom}}$ ), 5.72 (br s, 2H,  $\text{NH}_2$ ), 4.50–4.37 (m, 1H,  $\text{CH}_X$ ), 3.04–2.71 (m, 2H,  $\text{H}_A\text{H}_B$ ), 2.21 (s, 3H,  $\text{CH}_3$ );  $^{13}\text{C}$  NMR (125 MHz,  $\text{DMSO-}d_6$ )  $\delta$  172.8 (COOH), 147.9, 136.6, 135.5, 134.5, 129.8, 129.4, 128.8, 128.1, 127.9, 127.8, 127.4, 36.7, 33.4, 21.0 ( $\text{CH}_3$ ); MS ( $m/z$ ) (%): 321 (25) [ $\text{M}^+$ ], 303 (25), 262 (100), 247 (15), 204 (10), 172 (11), 142 (20), 115 (22), 84 (22); anal. calcd for  $\text{C}_{19}\text{H}_{19}\text{N}_3\text{O}_2$  (321.15) C, 71.01; H, 5.96; N, 13.08; found: C, 70.98; H, 6.06; N, 13.85.

**General procedure for the synthesis of 5-amino-3-(arylideneamino)-1,7-diaryl-7*H*-pyrrolo[1,2-*c*]imidazole-6-carbonitriles:**

A mixture of the corresponding 2-amino-4-arylimidazole **1** (1.0 mmol), aromatic aldehyde **2** (2.0 mmol) and malononitrile **12** (1.0 mmol) in 2 mL of 2-propanol was refluxed during 20–30 min. After cooling, the yellow solid products **14** were filtered off and crystallized from *i*PrOH. **14a**: yellow powder, 65%; mp 221–222 °C;  $^1\text{H}$  NMR (200 MHz,  $\text{DMSO-}d_6$ )  $\delta$  9.34 (s, 1H,  $\text{CH}_{\text{azomethine}}$ ), 8.18 (d,  $J = 7.3$  Hz, 2H, Ar), 7.68–7.48 (m, 7H, Ar,  $\text{C}^5\text{NH}_2$ ), 7.31–7.10 (m, 8H, Ar), 5.34 (s, 1H,  $\text{C}^7\text{H}$ );  $^{13}\text{C}$  NMR (125 MHz,  $\text{DMSO-}d_6$ )  $\delta$  162.4 ( $\text{C}^3$ ), 149.5 ( $\text{C}_{\text{azomethine}}$ ), 143.8 ( $\text{C}^5$ ), 138.3, 135.3, 133.3, 133.0, 132.5, 132.1, 130.4, 129.5, 129.4, 128.8, 128.2, 128.1, 127.4, 125.8, 117.9 (CN), 71.7 ( $\text{C}^6$ ), 45.01 ( $\text{C}^7$ ); MS ( $m/z$ ) (%): 429 ([ $\text{M}^+$ ], 25), 285 (100), 194 (19), 104 (26), 77 (19), 43 (25); anal. calcd for  $\text{C}_{28}\text{H}_{23}\text{N}_5$  (429.53) C, 78.30; H, 5.40; N, 16.31; found: C, 80.25; H, 5.70; N, 13.41.

**General procedure for the synthesis of 5-amino-1,7-diaryl-3-(arylideneamino)-7*H*-pyrrolo[1,2-*c*]imidazole-6-carboxylates:**

A mixture of the corresponding 2-amino-4-arylimidazole **1** (1.0 mmol), aromatic aldehyde **2** (2.0 mmol) and ethyl 2-cyanoacetate **15** (1.0 mmol) in 2 mL of 2-propanol was refluxed during 20–30 min. After cooling, the yellow solid products **16** were filtered off and crystallized from *i*PrOH. **16a**: yellow powder, 30%, mp 239–240 °C;  $^1\text{H}$  NMR (200 MHz,  $\text{DMSO-}d_6$ )  $\delta$  9.32 (s, 1H,  $\text{CH}_{\text{azomethine}}$ ), 8.12 (d,  $J = 6.7$  Hz, 2H, Ar), 7.67–7.45 (m, 5H, Ar), 7.27–7.04 (m, 10H,  $\text{C}^5\text{NH}_2$ , Ar), 5.15 (s,  $J = 6.7$  Hz, 1H,  $\text{C}^7\text{H}$ ), 4.05–3.84 (m, 2H,  $\text{OCH}_2\text{CH}_3$ ), 1.01 (s,  $J = 7.0$ , 3H,  $\text{OCH}_2\text{CH}_3$ );  $^{13}\text{C}$  NMR (125 MHz,  $\text{DMSO-}d_6$ )  $\delta$  178.7 (CO), 134.5, 133.3, 130.2, 129.6, 128.7, 128.6, 128.3,

127.8, 127.2, 127.0, 126.4, 125.8, 125.5, 116.7, 93.4, 58.9, 43.4, 14.7; MS (*m/z*) (%): 448 ([M<sup>++</sup>], 100; anal. calcd. for C<sub>28</sub>H<sub>24</sub>N<sub>4</sub>O<sub>2</sub> (448.19) C, 74.98; H, 5.39; N, 12.49; found: C, 75.12; H, 4.89; N, 11.37.

**General procedure for the synthesis of 3',5'-diamino-1-alkyl-2-oxo-1'-arylspiro[indolin-3,7'-pyrrolo[1,2-*c*]imidazole]-6'-carbonitriles:** The mixture of corresponding 2-amino-4-arylimidazoles **1** (1.0 mmol), isatin **18** (1.0 mmol) and malononitrile **12** (1.0 mmol) in 2 mL of 2-propanol was refluxed during 50–60 min. After cooling, the solid products **19** were filtered off and crystallized from iPrOH. **19a**: colourless solid, 60%, mp 250–252 °C; <sup>1</sup>H NMR (200 MHz, DMSO-*d*<sub>6</sub>) δ 7.77 (br s, 2H, C<sup>5</sup>NH<sub>2</sub>), 7.37 (t, *J* = 7.9 Hz, 1H, Ar<sub>isatin</sub>), 7.24–7.10 (m, 2H, Ar), 7.10–6.95 (m, 4H, Ar), 6.94–6.82 (m, 2H, Ar), 6.47 (br s, 2H, C<sup>3</sup>NH<sub>2imidazole</sub>), 3.21 (s, 3H, N<sup>1</sup>CH<sub>3</sub>); <sup>13</sup>C NMR (125 MHz, DMSO-*d*<sub>6</sub>) δ 176.3 (C<sup>2</sup>), 154.2 (C<sup>5</sup>), 146.4 (C<sup>3</sup>), 145.7, 135.4, 133.0, 132.2, 130.7, 130.3, 129.0, 127.2, 126.6, 126.1, 126.0, 111.7, 69.8 (C<sup>6</sup>), 55.8 (C<sub>spiro</sub>), 29.2 (N<sup>1</sup>CH<sub>3</sub>); MS (*m/z*) (%): 369 [M + H]<sup>+</sup> (100); anal. calcd for C<sub>21</sub>H<sub>16</sub>N<sub>6</sub>O (368.14) C, 68.47; H, 4.38; N, 22.81; found: C, 69.43; H, 5.07; N, 22.64.

**General procedure for the synthesis of 3',5'-diamino-1-alkyl-2-oxo-1'-arylspiro[indoline-3,7'-pyrrolo[1,2-*c*]imidazole]-6'-carboxylates:** The mixture of corresponding 2-amino-4-arylimidazoles **1** (1.0 mmol), isatin **18** (1.0 mmol) and ethyl 2-cyanoacetate **15** (1.0 mmol) in 2 mL of 2-propanol was refluxed during 50–60 min. After cooling, the solid products **20** were filtered off and crystallized from iPrOH. **20a**: colourless solid, 72%, mp 280–282 °C; <sup>1</sup>H NMR (200 MHz, DMSO-*d*<sub>6</sub>) δ 7.63 (br s, 2H, C<sup>5</sup>NH<sub>2</sub>), 7.29 (t, *J* = 7.5 Hz, 1H, Ar), 7.11–6.88 (m, 8H, Ar), 6.46 (br s, 2H, C<sup>3</sup>NH<sub>2</sub>), 3.83–3.63 (m, 2H, COCH<sub>2</sub>CH<sub>3</sub>), 3.21 (s, 3H, N<sup>1</sup>CH<sub>3</sub>), 0.88–0.69 (m, 3H, COCH<sub>2</sub>CH<sub>3</sub>); <sup>13</sup>C NMR (125 MHz, DMSO-*d*<sub>6</sub>) δ 175.0 (C<sup>2</sup>), 145.0 (C<sup>5</sup>), 143.7 (C<sup>3</sup>), 133.6, 130.4, 130.2, 129.0, 128.5, 126.7, 125.3, 125.0, 123.5, 123.1, 108.6, 58.5 (C<sup>6</sup>), 52.7 (C<sub>spiro</sub>), 33.4 (COCH<sub>2</sub>CH<sub>3</sub>), 26.9 (N<sup>1</sup>CH<sub>3</sub>), 14.3 (COCH<sub>2</sub>CH<sub>3</sub>); MS (*m/z*) (%): 416 [M + H]<sup>+</sup> (100); anal. calcd for C<sub>23</sub>H<sub>21</sub>N<sub>5</sub>O<sub>3</sub> (415.16) C, 66.49; H, 5.09; N, 16.86; found: C, 67.89; H, 5.64; N, 11.70.

### Experimental part of X-ray diffraction study

The crystals of **9i** (C<sub>24</sub>H<sub>20</sub>N<sub>3</sub>O<sup>+</sup>, C<sub>2</sub>F<sub>3</sub>O<sub>2</sub><sup>−</sup>) are triclinic. At 293 K *a* = 8.4770(6), *b* = 11.317(1), *c* = 13.027(1) Å, α = 69.101(9)°, β = 77.989(8)°, γ = 87.527(7)°, *V* = 1141.3(2) Å<sup>3</sup>, *M*<sub>r</sub> = 479.45, *Z* = 2, space group *P* $\bar{1}$ , *d*<sub>calc</sub> = 1.395 g/cm<sup>3</sup>, μ(Mo Kα) = 0.109 mm<sup>−1</sup>, F(000) = 496. Intensities of 8769 reflections (3910 independent, *R*<sub>int</sub> = 0.027) were measured on the «Xcalibur-3» diffractometer (graphite monochromated Mo Kα radiation, CCD detector, ω-scanning, 2Θ<sub>max</sub> = 50°).

The crystals of **11b** (C<sub>19</sub>H<sub>19</sub>N<sub>3</sub>O<sub>2</sub>·H<sub>2</sub>O) are monoclinic. At 293 K *a* = 16.4288(9), *b* = 9.3556(4), *c* = 12.1174(8) Å, β = 110.151(7)°, *V* = 1748.5(2) Å<sup>3</sup>, *M*<sub>r</sub> = 339.39, *Z* = 4, space group *P*21/*c*, *d*<sub>calc</sub> = 1.289 g/cm<sup>3</sup>, μ(Mo Kα) = 0.089 mm<sup>−1</sup>, F(000) = 720. Intensities of 16955 reflections (5089 independent, *R*<sub>int</sub> = 0.060) were measured on the «Xcalibur-3» diffractometer (graphite monochromated Mo Kα radiation, CCD detector, ω-scanning, 2Θ<sub>max</sub> = 60°).

The crystals of **16a** (C<sub>28</sub>H<sub>24</sub>N<sub>4</sub>O<sub>2</sub>) are triclinic. At 293 K *a* = 8.322(3) Å, *b* = 9.563(6) Å, *c* = 16.053(5) Å, α = 94.08(4)°, β = 101.46(3)°, γ = 109.97(4)°, *V* = 1163.3(10) Å<sup>3</sup>, *M*<sub>r</sub> = 448.53, *Z* = 2, space group *P* $\bar{1}$ , *d*<sub>calc</sub> = 1.2804 g/cm<sup>3</sup>, μ(Mo Kα) = 0.083 mm<sup>−1</sup>, F(000) = 472. Intensities of 12048 reflections (3968 independent, *R*<sub>int</sub> = 0.167) were measured on the «Xcalibur-3» diffractometer (graphite monochromated Mo Kα radiation, CCD detector, ω-scanning, 2Θ<sub>max</sub> = 50°).

The crystals of **19a** (C<sub>24</sub>H<sub>25</sub>N<sub>7</sub>O<sub>3</sub>) are triclinic. At 293 K *a* = 7.9380(5) Å, *b* = 8.4953(5) Å, *c* = 17.6908(9) Å, α = 98.891(4)°, β = 101.017(5)°, γ = 91.630(5)°, *V* = 1154.86(12) Å<sup>3</sup>, *M*<sub>r</sub> = 459.51, *Z* = 2, space group *P* $\bar{1}$ , *d*<sub>calc</sub> = 1.321 g/cm<sup>3</sup>, μ(Mo Kα) = 0.091 mm<sup>−1</sup>, F(000) = 484. Intensities of 11884 reflections (6633 independent, *R*<sub>int</sub> = 0.0265) were measured on the «Xcalibur-3» diffractometer (graphite monochromated Mo Kα radiation, CCD detector, ω-scanning, 2Θ<sub>max</sub> = 50°).

The structures were solved by direct methods using the SHELXTL package [41]. The position of the hydrogen atoms were located from electron density difference maps and refined by the “riding” model with *U*<sub>iso</sub> = *nU*<sub>eq</sub> of the carrier atom (*n* = 1.5 for methyl and hydroxy groups and for water molecules and *n* = 1.2 for other hydrogen atoms) in the structures **11b** and **16a**. The hydrogen atoms of the compounds **11b** and **19a** which take part in the formation of the hydrogen bonds were refined using the isotropic approximation as well as all hydrogen atoms in the structure **9i**. Full-matrix least-squares refinement of the structures against F<sup>2</sup> in anisotropic approximation for non-hydrogen atoms using 3879 (**9i**), 5051 (**11b**), 3968 (**16a**) and 6633 (**19a**) reflections was converged to: *wR*<sub>2</sub> = 0.052 (*R*<sub>1</sub> = 0.031 for 1903 reflections with *F* > 4σ(*F*), *S* = 0.964) for structure **9i**, *wR*<sub>2</sub> = 0.117 (*R*<sub>1</sub> = 0.054 for 2480 reflections with *F* > 4σ(*F*), *S* = 0.992) for structure **11b**, *wR*<sub>2</sub> = 0.107 (*R*<sub>1</sub> = 0.079 for 942 reflections with *F* > 4σ(*F*), *S* = 0.881) for structure **16a** and *wR*<sub>2</sub> = 0.147 (*R*<sub>1</sub> = 0.065 for 3693 reflections with *F* > 4σ(*F*), *S* = 1.045) for structure **19a**. The final atomic coordinates, and crystallographic data for molecules **9i** and **11b** have been deposited to with the Cambridge Crystallographic Data Centre, 12 Union Road, CB2 1EZ, UK (fax: +44-1223-336033; e-mail: [deposit@ccdc.cam.ac.uk](mailto:deposit@ccdc.cam.ac.uk)) and are available on request quoting the deposition numbers CCDC 1855490 for **9i**, CCDC

1855491 for **11b**, CCDC 1895778 for **16a** and CCDC 1895793 for **19a**).

## Supporting Information

### Supporting Information File 1

Experimental and analytical data, X-ray diffraction studies and NMR spectra.

[<https://www.beilstein-journals.org/bjoc/content/supplementary/1860-5397-15-101-S1.pdf>]

## Acknowledgements

The authors thank the National Academy of Sciences of Ukraine for financial support in the frame of the projects "Creation of modern bases for obtaining and analyzing substances and components of materials for pharmaceutical purposes" (0119U100727) and "Investigation of structural features of nitrogen containing heterocycles with potential biological activity" (0119U100716).

## ORCID® iDs

Irina S. Konovalova - <https://orcid.org/0000-0001-6245-6642>

Svetlana V. Shiskina - <https://orcid.org/0000-0002-3946-1061>

## References

- Lejeune, C.; Tian, H.; Appenzeller, J.; Ermolenko, L.; Martin, M.-T.; Al-Mourabit, A. *J. Nat. Prod.* **2013**, *76*, 903–908. doi:10.1021/np400048r
- Edrada, R. A.; Stessman, C. C.; Crews, P. *J. Nat. Prod.* **2003**, *66*, 939–942. doi:10.1021/np020503d
- Gautschi, J. T.; Whitman, S.; Holman, T. R.; Crews, P. *J. Nat. Prod.* **2004**, *67*, 1256–1261. doi:10.1021/np0340495
- Tilvi, S.; Moriou, C.; Martin, M.-T.; Gallard, J.-F.; Sorres, J.; Patel, K.; Petek, S.; Debitus, C.; Ermolenko, L.; Al-Mourabit, A. *J. Nat. Prod.* **2010**, *73*, 720–723. doi:10.1021/np900539j
- Wang, Y.-G.; Morinaka, B. I.; Reyes, J. C. P.; Wolff, J. J.; Romo, D.; Molinski, T. F. *J. Nat. Prod.* **2010**, *73*, 428–434. doi:10.1021/np900638e
- Smith, S. E.; Dello Buono, M. C.; Carper, D. J.; Coleman, R. S.; Day, B. W. *J. Nat. Prod.* **2014**, *77*, 1572–1578. doi:10.1021/np4010882
- Kobayashi, J.; Nakamura, H.; Ohizumi, Y. *Experientia* **1988**, *44*, 86–87. doi:10.1007/bf01960260
- Chan, G. W.; Mong, S.; Hemling, M. E.; Freyer, A. J.; Offen, P. H.; DeBrosse, C. W.; Sarau, H. M.; Westley, J. W. *J. Nat. Prod.* **1993**, *56*, 116–121. doi:10.1021/np50091a016
- Meijer, L.; Thunnissen, A.-M.; White, A.; Garnier, M.; Nikolic, M.; Tsai, L.-H.; Walter, J.; Cleverley, K.; Salinas, P.; Wu, Y.-Z.; Biernat, J.; Mandelkow, E.-M.; Kim, S.-H.; Pettit, G. R. *Chem. Biol.* **2000**, *7*, 51–63. doi:10.1016/s1074-5521(00)00063-6
- Tasdemir, D.; Mallon, R.; Greenstein, M.; Feldberg, L. R.; Kim, S. C.; Collins, K.; Wojciechowicz, D.; Mangalindan, G. C.; Concepción, G. P.; Harper, M. K.; Ireland, C. M. *J. Med. Chem.* **2002**, *45*, 529–532. doi:10.1021/jm0102856
- Dunbar, D. C.; Rimoldi, J. M.; Clark, A. M.; Kelly, M.; Hamann, M. T. *Tetrahedron* **2000**, *56*, 8795–8798. doi:10.1016/s0040-4020(00)00821-8
- Fu, X.; Schmitz, F. J.; Tanner, R. S.; Kelly-Borges, M. *J. Nat. Prod.* **1998**, *61*, 384–386. doi:10.1021/np970453q
- Cafieri, F.; Carnuccio, R.; Fattorusso, E.; Tagliatalata-Scafati, O.; Vallefucio, T. *Bioorg. Med. Chem. Lett.* **1997**, *7*, 2283–2288. doi:10.1016/s0960-894x(97)00415-0
- Gibbons, J. B.; Gligorich, K. M.; Welm, B. E.; Looper, R. E. *Org. Lett.* **2012**, *14*, 4734–4737. doi:10.1021/ol3019242
- Jacquot, D. E. N.; Lindel, T. *Curr. Org. Chem.* **2005**, *9*, 1551–1565. doi:10.2174/138527205774370531
- Su, S.; Rodriguez, R. A.; Baran, P. S. *J. Am. Chem. Soc.* **2011**, *133*, 13922–13925. doi:10.1021/ja206191g
- Ermolat'ev, D. S.; Babaev, E. V.; Van der Eycken, E. V. *Org. Lett.* **2006**, *8*, 5781–5784. doi:10.1021/ol062421c
- Ermolat'ev, D. S.; Van der Eycken, E. V. *J. Org. Chem.* **2008**, *73*, 6691–6697. doi:10.1021/jo8008758
- Ermolat'ev, D. S.; Svidritsky, E. P.; Babaev, E. V.; Van der Eycken, E. *Tetrahedron Lett.* **2009**, *50*, 5218–5220. doi:10.1016/j.tetlet.2009.06.128
- Ermolat'ev, D. S.; Alifanov, V. L.; Rybakov, V. B.; Babaev, E. V.; Van der Eycken, E. V. *Synthesis* **2008**, 2083–2088. doi:10.1055/s-2008-1078444
- Modha, S. G.; Mehta, V. P.; Ermolat'ev, D.; Balzarini, J.; Van Hecke, K.; Van Meervelt, L.; Van der Eycken, E. *Mol. Diversity* **2010**, *14*, 767–776. doi:10.1007/s11030-009-9221-1
- Steenackers, H. P. L.; Ermolat'ev, D. S.; Savaliya, B.; De Weerd, A.; De Coster, D.; Shah, A.; Van der Eycken, E. V.; De Vos, D. E.; Vanderleyden, J.; De Keersmaecker, S. C. J. *J. Med. Chem.* **2011**, *54*, 472–484. doi:10.1021/jm1011148
- Steenackers, H. P. L.; Ermolat'ev, D. S.; Savaliya, B.; De Weerd, A.; De Coster, D.; Shah, A.; Van der Eycken, E. V.; De Vos, D. E.; Vanderleyden, J.; De Keersmaecker, S. C. J. *Bioorg. Med. Chem.* **2011**, *19*, 3462–3473. doi:10.1016/j.bmc.2011.04.026
- Andriushchenko, A. Yu.; Saraev, V. E.; Shishkina, S. V.; Shishkin, O. V.; Musatov, V. I.; Desenko, S. M.; Chebanov, V. A. *ARKIVOC* **2013**, No. iii, 61–80. doi:10.3998/ark.5550190.0014.306
- Lipson, V. V.; Gorobets, N. Y. *Mol. Diversity* **2009**, *13*, 399–419. doi:10.1007/s11030-009-9136-x
- Oikawa, Y.; Hirasawa, H.; Yonemitsu, O. *Tetrahedron Lett.* **1978**, *19*, 1759–1762. doi:10.1016/0040-4039(78)80037-9
- Dardennes, E.; Kovács-Kulyassa, Á.; Renzetti, A.; Sapi, J.; Laronze, J.-Y. *Tetrahedron Lett.* **2003**, *44*, 221–223. doi:10.1016/s0040-4039(02)02537-6
- Jeannin, L.; Boisbrun, M.; Nemes, C.; Cochard, F.; Laronze, M.; Dardennes, E.; Kovács-Kulyassa, Á.; Sapi, J.; Laronze, J.-Y. *C. R. Chim.* **2003**, *6*, 517–528. doi:10.1016/s1631-0748(03)00092-4
- Cochard, F.; Laronze, M.; Sigaut, P.; Sapi, J.; Laronze, J.-Y. *Tetrahedron Lett.* **2004**, *45*, 1703–1707. doi:10.1016/j.tetlet.2003.12.099
- Dardennes, E.; Kovács-Kulyassa, Á.; Boisbrun, M.; Petermann, C.; Laronze, J.-Y.; Sapi, J. *Tetrahedron: Asymmetry* **2005**, *16*, 1329–1339. doi:10.1016/j.tetasy.2005.02.008
- Gerencsér, J.; Panka, G.; Nagy, T.; Egyed, O.; Dormán, G.; Úrge, L.; Darvas, F. *J. Comb. Chem.* **2005**, *7*, 530–538. doi:10.1021/cc040101j
- Bürgi, H.-B.; Dunitz, J. D., Eds. *Structure correlation*; VCH: Weinheim, Germany, 1994; pp 741–784. doi:10.1002/9783527616091

33. Tsuji, M.; Inoue, H.; Tanoue, Y.; Beppu, K.; Saita, M.; Taniguchi, Y.; Furuta, K.; Deguchi, Y.; Noda, K.  
3-Aroyl-6,7-dihydro-5H-pyrrolo(1,2-c)imidazole-7-carboxylic acid derivatives. U.S. Pat. Appl. US4895956A, Jan 23, 1990.
34. Chatterjee, S.; Ye, G.; Pittman, C. U., Jr. *Tetrahedron Lett.* **2010**, *51*, 1139–1144. doi:10.1016/j.tetlet.2009.10.116
35. Meredith, E. L.; Ksander, G.; Monovich, L. G.; Papillon, J. P. N.; Liu, Q.; Miranda, K.; Morris, P.; Rao, C.; Burgis, R.; Capparelli, M.; Hu, Q.-Y.; Singh, A.; Rigel, D. F.; Jeng, A. Y.; Beil, M.; Fu, F.; Hu, C.-W.; LaSala, D. *ACS Med. Chem. Lett.* **2013**, *4*, 1203–1207. doi:10.1021/ml400324c
36. Ksander, G. M.; Meredith, E. M.; Monovich, L. G.; Papillon, J.; Firooznia, F.; Hu, Q.-Y. Condensed imidazole derivatives for the inhibition of aldosterone synthase and aromatase. WO Patent WO2007024945, March 1, 2007.
37. Pavlovska, T. L.; Redkin, R. G.; Lipson, V. V.; Atamanuk, D. V. *Mol. Diversity* **2016**, *20*, 299–344. doi:10.1007/s11030-015-9629-8
38. da Silva, J. F. M.; Garden, S. J.; Pinto, A. C. *J. Braz. Chem. Soc.* **2001**, *12*, 273–324. doi:10.1590/s0103-50532001000300002
39. Zhou, F.; Liu, Y.-L.; Zhou, J. *Adv. Synth. Catal.* **2010**, *352*, 1381–1407. doi:10.1002/adsc.201000161
40. Mohammadi, S.; Heiran, R.; Herrera, R. P.; Marqués-López, E. *ChemCatChem* **2013**, *5*, 2131–2148. doi:10.1002/cctc.201300050
41. Sheldrick, G. M. *Acta Crystallogr., Sect. A: Found. Crystallogr.* **2008**, *64*, 112–122. doi:10.1107/s0108767307043930

## License and Terms

This is an Open Access article under the terms of the Creative Commons Attribution License (<http://creativecommons.org/licenses/by/4.0>). Please note that the reuse, redistribution and reproduction in particular requires that the authors and source are credited.

The license is subject to the *Beilstein Journal of Organic Chemistry* terms and conditions: (<https://www.beilstein-journals.org/bjoc>)

The definitive version of this article is the electronic one which can be found at:  
[doi:10.3762/bjoc.15.101](https://doi.org/10.3762/bjoc.15.101)



## A three-component, Zn(OTf)<sub>2</sub>-mediated entry into trisubstituted 2-aminoimidazoles

Alexei Lukin<sup>1</sup>, Anna Bakholdina<sup>1</sup>, Anna Kryukova<sup>1</sup>, Alexander Sapegin<sup>2</sup> and Mikhail Krasavin<sup>\*2</sup>

### Letter

Open Access

#### Address:

<sup>1</sup>Lomonosov Institute of Fine Chemical Technologies, MIREA – Russian Technological University, Moscow 119571, Russian Federation and <sup>2</sup>Saint Petersburg State University, Saint Petersburg 199034, Russian Federation

#### Email:

Mikhail Krasavin\* - m.krasavin@spbu.ru

\* Corresponding author

#### Keywords:

alkyne hydroamination; cyclocondensation; Lewis acid catalysis; multicomponent reactions; propargylurea

*Beilstein J. Org. Chem.* **2019**, *15*, 1061–1064.

doi:10.3762/bjoc.15.103

Received: 23 February 2019

Accepted: 29 April 2019

Published: 07 May 2019

This article is part of the thematic issue "Multicomponent reactions III".

Guest Editor: T. J. J. Müller

© 2019 Lukin et al.; licensee Beilstein-Institut.

License and terms: see end of document.

## Abstract

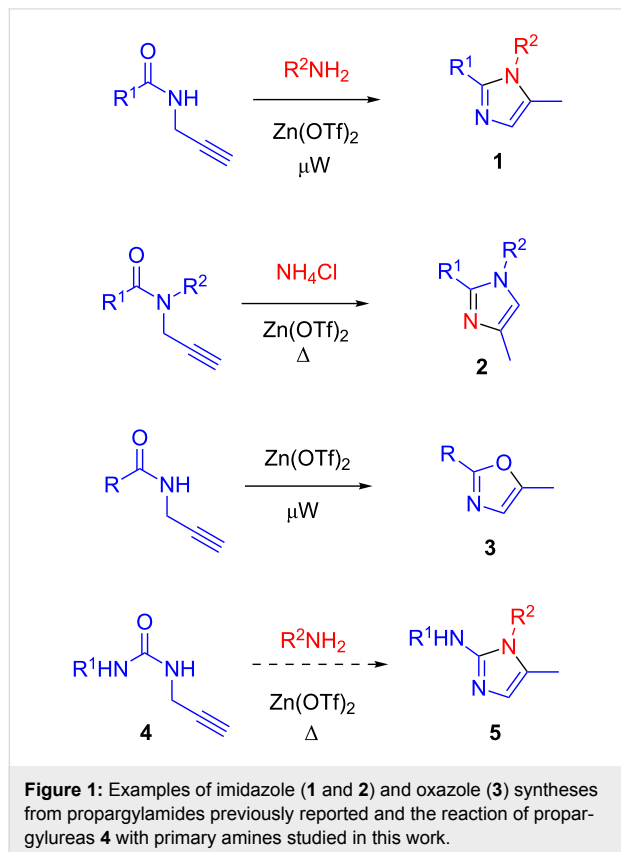
A three-component reaction involving in situ generation of propargylureas and subsequent Zn(OTf)<sub>2</sub>-mediated cyclocondensation with a primary amine yielded trisubstituted 2-aminoimidazoles. These findings are in contrast to the previously reported base-promoted unimolecular cyclization of propargylureas (leading to 2-imidazolones) and extend the range of Lewis acid-catalyzed azole syntheses based on *N*-carbonyl propargylamines.

## Introduction

The pioneering publications of Beller and co-workers describing Zn(OTf)<sub>2</sub>-catalyzed, microwave-promoted conversion of a mixture of a secondary propargylamide and an amine into a trisubstituted imidazole **1** [1,2] inspired us to explore several variants of this methodology. Last year, we described the synthesis of differently substituted imidazoles **2** from tertiary propargylamides and ammonium chloride under conventional heating [3]. More recently, we applied the Beller protocol to the synthesis of 2-substituted 5-methyloxazoles **3** from secondary propargylamides [4]. Being curious to explore more variants of *N*-carbonyl propargylamines, we turned our attention to propargylureas **4**. These have been previously con-

verted to the respective 2-imidazolones via base-promoted intramolecular amination of the propargyl group [5,6]. However, such transformations have not been studied under transition metal or Lewis acid catalysis. Moreover, the possibility to incorporate of an external primary amine into the cyclization process, which would lead to trisubstituted 2-aminoimidazoles **5** has not been explored (Figure 1). 2-Aminoimidazoles have a remarkably broad utility in medicinal chemistry [7]. Moreover, ureas **4** can, in principle, be generated in situ from the respective isocyanates and propargylamine (or propargyl isocyanate and primary amines), thus could offer an opportunity to synthesize 2-aminoimidazoles **5** in a three-component format. Consid-

ering these premises, we started to explore the  $\text{Zn}(\text{OTf})_2$ -catalyzed reaction of **4** with primary amines. Herein, we present the preliminary results of these studies.



## Results and Discussion

Urea **4a** (prepared by reacting propargylamine with 4-(trifluoromethoxy)benzyl isocyanate) was reacted with an equivalent

amount of benzylamine in refluxing toluene in the presence of various Lewis acids. To our delight, the desired product **5a** was observed and isolated in all cases involving  $\text{Zn}(\text{OTf})_2$  catalysis. However, in contrast to previous reports on the preparation of related compounds [1-4], the reaction required substantial amounts (optimally, 50 mol %) of  $\text{Zn}(\text{OTf})_2$  to achieve the best yield (76%). Notably, neither  $\text{Sc}(\text{OTf})_2$  nor  $\text{Cu}(\text{OTf})_2$  employed as catalysts produced a trace of the desired product. To rule out catalysis by adventitious TfOH, the reaction was performed in the presence of an equimolar amount of triflic acid, but no conversion could be detected (Table 1).

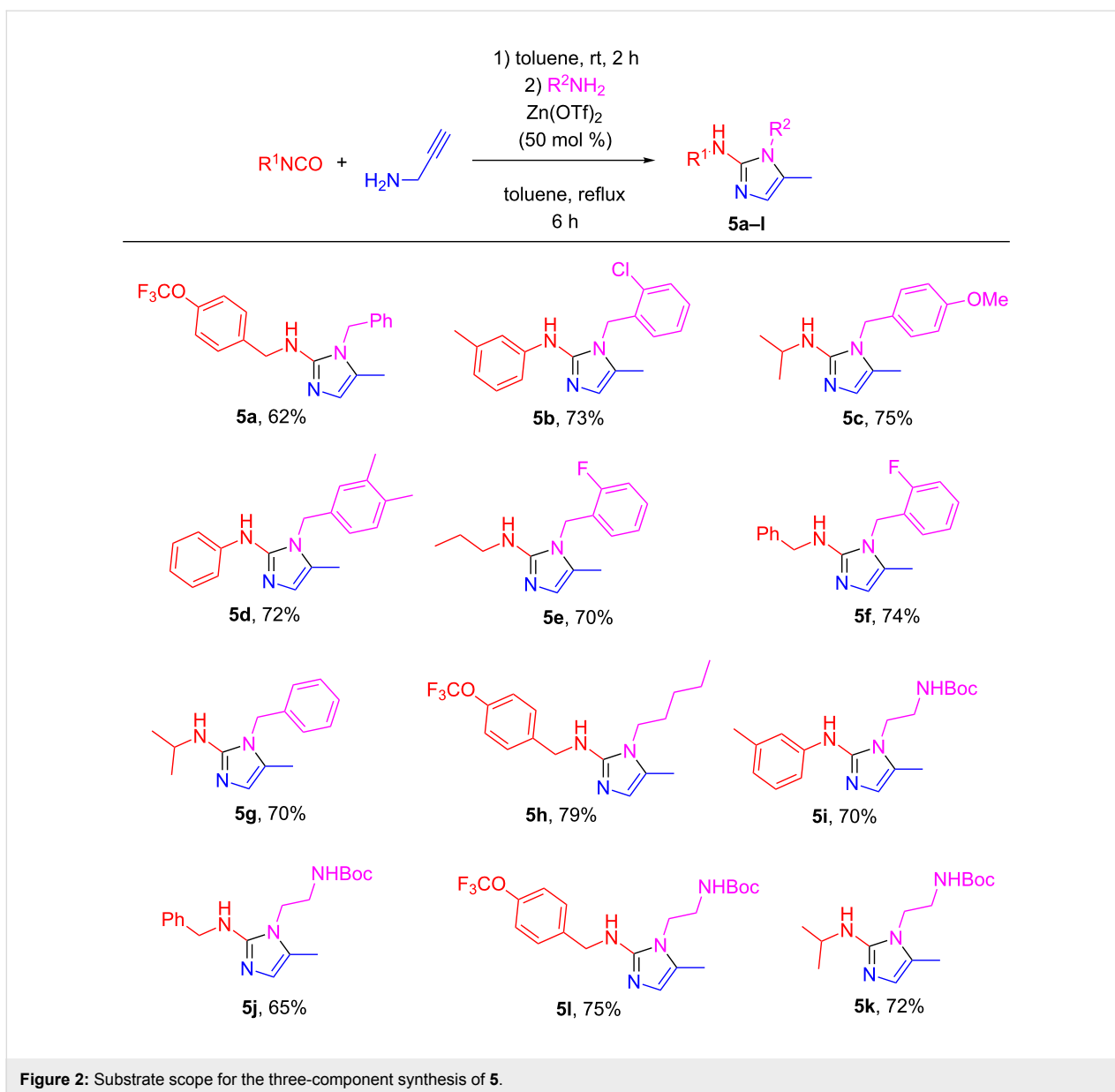
Considering that in situ preparation of ureas **4** could, in principle, enable a three-component entry to imidazoles **5** (an attractive option from the standpoint of library array synthesis), we compared the isolated yield of the above reaction (with the ready-made urea **4a**) with the yield obtained in the three-component format. To our delight, the three-component format led to only a slightly lower yield of **5a** (62%). Viewing this as a worthy toll for the convenience of multicomponent chemistry, we proceeded investigating the scope of the newly established synthesis of trisubstituted 2-aminoimidazoles **5** (Figure 2).

As it is evident from the data presented in Figure 2, the newly developed approach to the synthesis of medicinally important 2-imidazolines allows for independent variation of two periphery elements and provides generally good yields of the target compounds. The reaction can be performed with both, aromatic and aliphatic isocyanates. However, its scope is limited to aliphatic amines as the reaction failed to work for anilines (even electron-rich ones, such as *p*-anisidine). The tolerance of acid-labile protecting groups such as Boc is particularly useful as it offers an opportunity for further side-chain modifications.

**Table 1:** Catalyst screening results for the conversion of **4a** to **5a**.

The reaction scheme shows the conversion of urea **4a** (with a trifluoromethoxy group) to 2-imidazole **5a** (with a benzyl group and a phenyl group) using  $\text{BnNH}_2$  as a catalyst in toluene at reflux for 12 hours.

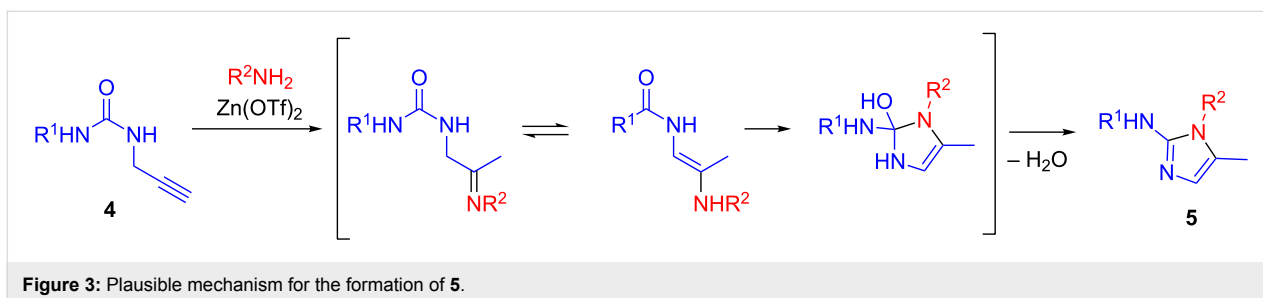
Entry	Catalyst	Isolated yield (%)
1	$\text{Zn}(\text{OTf})_2$ (5 mol %)	8
2	$\text{Zn}(\text{OTf})_2$ (25 mol %)	28
3	$\text{Zn}(\text{OTf})_2$ (50 mol %)	76
4	$\text{Sc}(\text{OTf})_2$ (25 mol %)	0
5	$\text{Cu}(\text{OTf})_2$ (25 mol %)	0
6	TfOH (100 mol %)	0
7	none	0



From the mechanistic prospective, the reaction probably proceeds via  $Zn(OTf)_2$ -catalyzed alkyne hydroamination followed by cyclodehydration as depicted in Figure 3, in full analogy with the previously proposed mechanism [2,3].

## Conclusion

In summary, we have successfully employed propargylureas in the synthesis of trisubstituted 2-aminoimidazoles. This is the first example illustrating the utility of such ureas in the synthe-



sis of imidazoles as previously reported syntheses only involved base-promoted cyclization into 2-imidazolones. The reaction can be conveniently conducted in a three-component format which makes it a useful tool for library array synthesis. The investigation of other metal-catalyzed transformations of propargylureas is underway in our laboratories and will be reported in due course.

## Supporting Information

### Supporting Information File 1

General experimental information, synthetic procedures, analytical data and NMR spectra for the reported compounds.

[<https://www.beilstein-journals.org/bjoc/content/supplementary/1860-5397-15-103-S1.pdf>]

## License and Terms

This is an Open Access article under the terms of the Creative Commons Attribution License (<http://creativecommons.org/licenses/by/4.0>). Please note that the reuse, redistribution and reproduction in particular requires that the authors and source are credited.

The license is subject to the *Beilstein Journal of Organic Chemistry* terms and conditions:

(<https://www.beilstein-journals.org/bjoc>)

The definitive version of this article is the electronic one which can be found at:

[doi:10.3762/bjoc.15.103](https://doi.org/10.3762/bjoc.15.103)

## Acknowledgements

This research was supported by the Russian Science Foundation (grant no. 17-73-20185). We thank the the Center for Chemical Analysis and Materials Research of the Saint Petersburg State University Research Park for measuring the analytical data.

## ORCID® iDs

Mikhail Krasavin - <https://orcid.org/0000-0002-0200-4772>

## References

- Pews-Davtyan, A.; Tillack, A.; Schmöle, A.-C.; Ortinou, S.; Frech, M. J.; Rofls, A.; Beller, M. *Org. Biomol. Chem.* **2010**, *8*, 1149–1153. doi:10.1039/b920861e
- Pews-Davtyan, A.; Beller, M. *Chem. Commun.* **2011**, *47*, 2152–2154. doi:10.1039/c0cc04625f
- Safrygin, A.; Krivosheyeva, E.; Dar'in, D.; Krasavin, M. *Synthesis* **2018**, *50*, 3048–3058. doi:10.1055/s-0036-1591599
- Safrygin, A.; Dar'in, D.; Lukin, A.; Bakhholdina, A.; Sapegin, A.; Krasavin, M. *Tetrahedron Lett.* **2019**, *60*, 777–779. doi:10.1016/j.tetlet.2019.02.011
- Samajdar, S.; Abbineni, C.; Sasmal, S.; Hosahalli, S. Bicyclic heterocyclic derivatives as bromodomain inhibitors. PCT Int. Appl. WO2015104653A1, July 16, 2018. *Chem. Abstr.* **2015**, *163*, 231586.
- Armani, E.; Capaldi, C.; Sutton, J. M.; Heald, R. A. Novel compounds. US Pat. Appl. US20160168101A1, June 16, 2016. *Chem. Abstr.* **2016**, *165*, 69015.
- Žula, A.; Kikelj, D.; Ilaš, J. *Mini-Rev. Med. Chem.* **2013**, *13*, 1921–1943. doi:10.2174/1389557511313130007

# Multicomponent reactions (MCRs): a useful access to the synthesis of benzo-fused $\gamma$ -lactams

Edorta Martínez de Marigorta, Jesús M. de Los Santos, Ana M. Ochoa de Retana, Javier Vicario\* and Francisco Palacios\*

## Review

Open Access

### Address:

Departamento de Química Orgánica I, Facultad de Farmacia, University of the Basque Country, UPV/EHU Paseo de la Universidad 7, 01006, Vitoria-Gasteiz, Spain

### Email:

Javier Vicario\* - javier.vicario@ehu.eus; Francisco Palacios\* - francisco.palacios@ehu.eus

\* Corresponding author

### Keywords:

indolin-2-ones; isoindolinones;  $\gamma$ -lactams; multicomponent reactions; 2-oxindoles

*Beilstein J. Org. Chem.* **2019**, *15*, 1065–1085.

doi:10.3762/bjoc.15.104

Received: 25 January 2019

Accepted: 17 April 2019

Published: 08 May 2019

This article is part of the thematic issue "Multicomponent reactions III".

Guest Editor: T. J. J. Müller

© 2019 de Marigorta et al.; licensee Beilstein-Institut.

License and terms: see end of document.

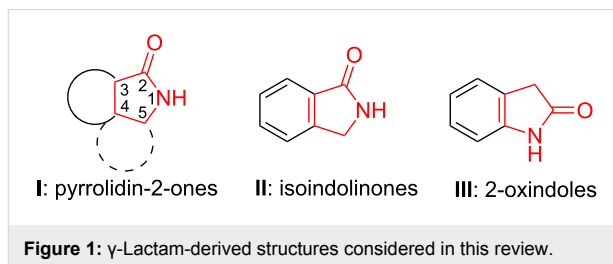
## Abstract

Benzo-fused  $\gamma$ -lactam rings such as isoindolin-2-ones and 2-oxindoles are part of the structure of many pharmaceutically active molecules. They can be often synthesized by means of multicomponent approaches and recent contributions in this field are summarized in this review. Clear advantages of these methods include the efficiency in saving raw materials and working time. However, there is still a need of new catalytic systems to allow the enantioselective preparation of these heterocycles by multicomponent reactions.

## Introduction

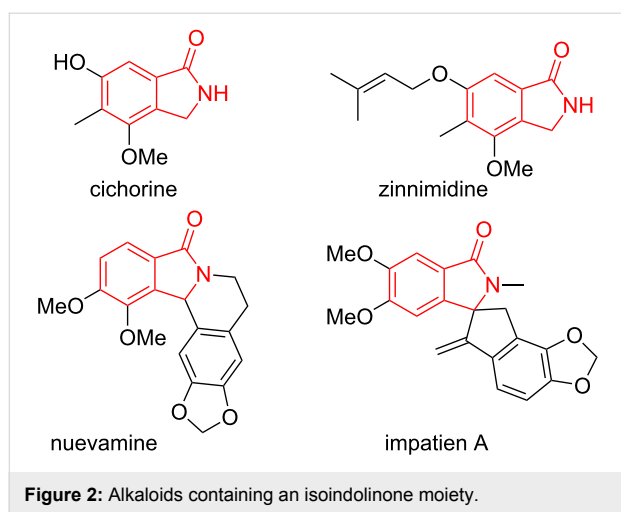
Pyrrolidin-2-ones (**I**, Figure 1) are heterocycles that contain a  $\gamma$ -lactam ring that can be found in many biologically active compounds with natural or synthetic origin [1]. When an aryl group is fused to the 3- and 4-positions of the five-membered heterocycle, isoindolinones (**II**, Figure 1) are generated, while if such fusion takes place between the 4- and 5-positions of the  $\gamma$ -lactam ring, 2-oxindoles (also named as indolin-2-ones **III**, Figure 1) are formed.

The isoindolinone structural motif is a part of the core of many natural products [2]. To cite some examples, cichorine [3] and zinnimidine [4] (Figure 2) are simple isoindolinone



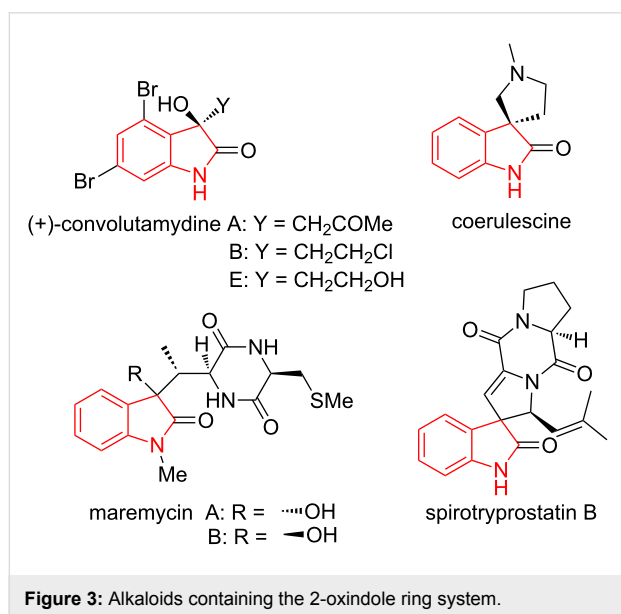
alkaloids, for which total syntheses have been reported [5], and nuevamine (Figure 2) is an isoindoloisoquinoline alkaloid [6,7]. Moreover, in this last decade, new compounds such as

impatien A [8] (Figure 2) or daldinans B and C [9] have been discovered.



**Figure 2:** Alkaloids containing an isoindolinone moiety.

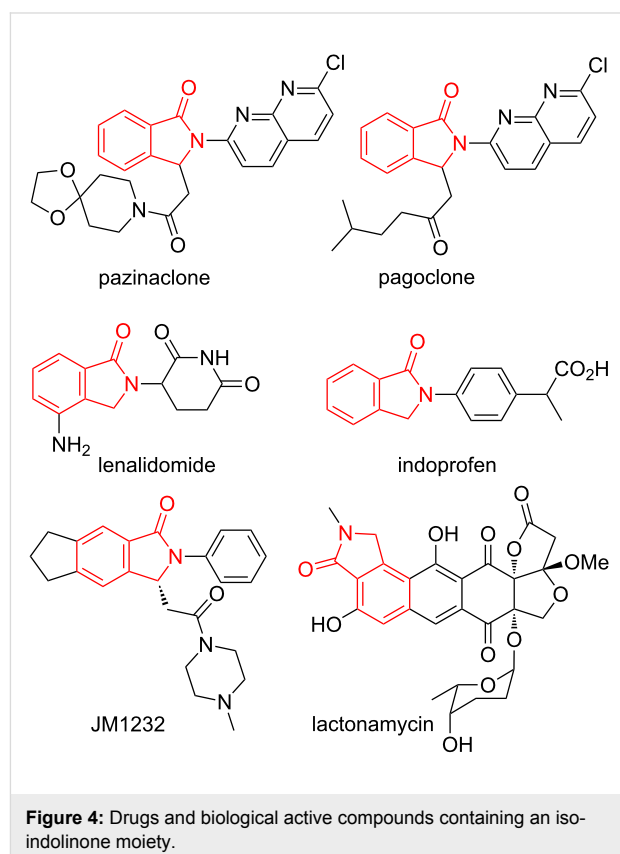
Similarly, the 2-oxindole framework is prevalent in a wide range of natural products [10]. For example, convolutamydines [11] are alkaloids containing a dibromohydroxyoxindole moiety, isolated from the Floridian bryozoan *Amathia convulata*, while coerulescine [12] is an oxindole alkaloid isolated from *Phalaris coerulescens* (Figure 3). Likewise, maremycins [13] and spirotryprostatin B [14] have been isolated from marine *Streptomyces* and from the fermentation broth of *Aspergillus fumigatus*.



**Figure 3:** Alkaloids containing the 2-oxindole ring system.

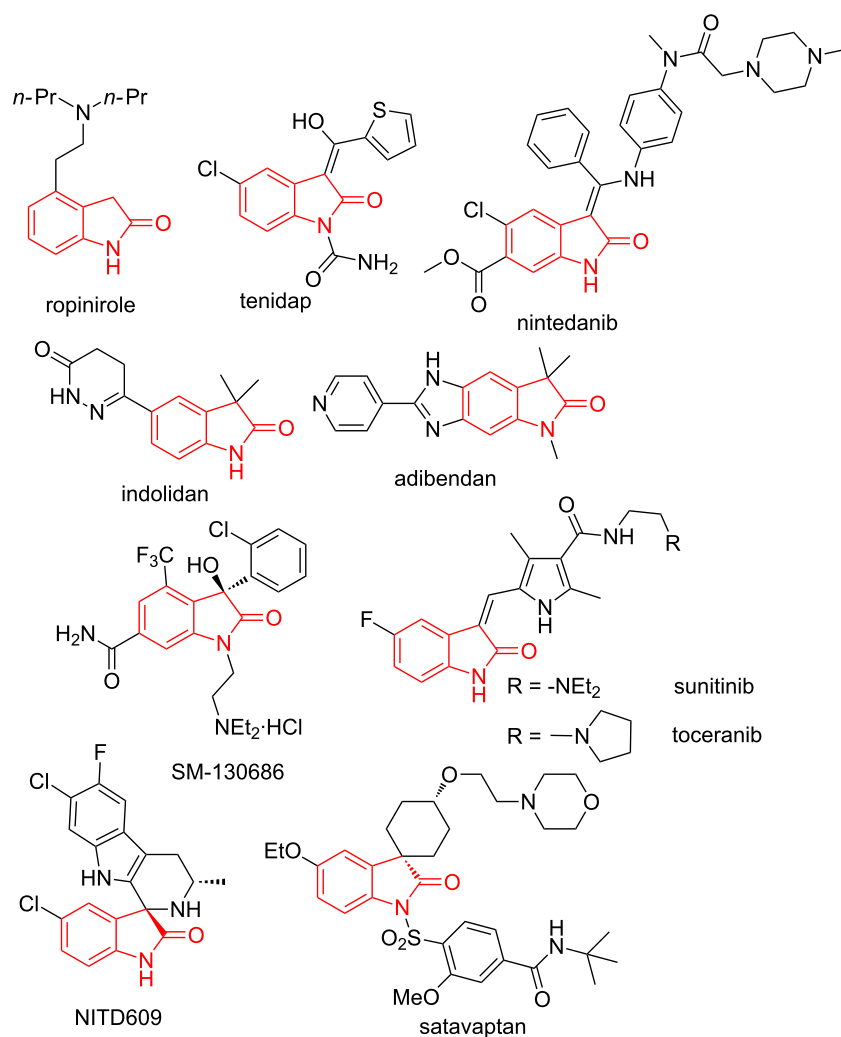
Among benzo-fused  $\gamma$ -lactam chemical entities, natural and synthetic isoindolinones are a prominent class of compounds. Molecules containing the isoindolinone moiety are of pharmaceuti-

cal interest as anxiolytic (pazinaclone [15], pagoclone [16], and JM1232 [17]), anticancer (lenalidomide) [18], anti-inflammatory (indoprofen) [19] and antibiotic agents (lactonamycin) [20] (Figure 4). In addition, some isoindolinone derivatives show a large variety of biological activities [21–23], such as COX-2 inhibition [24], glucokinase activation [25], sodium channel blocking [26], antimycobacterial [27], antiproliferative [28] or carbonic anhydrase inhibition [29], as well as antifungal and antibacterial properties [30].



**Figure 4:** Drugs and biological active compounds containing an isoindolinone moiety.

Isomeric 2-oxindoles are another family of aromatic-fused heterocycles containing the  $\gamma$ -lactam unit. These molecules are often biologically active and therefore, they have found many applications in medicinal chemistry. For example, ropinirole [31] is used in the treatment of early Parkinson's disease, nintedanib is employed against pulmonary fibrosis [32], tenidap [33] is a nonsteroidal anti-inflammatory drug (NSAID), while indolidan [34] and adibendan [35] are potent long-acting cardiotonic agents and SM-130686 is a GHSR agonist [36] (Figure 5). Other kinase inhibitors such as sunitinib [37] and toceranib [38] are also found in the market for the treatment of several tumours (Figure 5) and some others are under development or have been entered clinical trials [39]. There are also natural spirooxindole-containing complex molecules that have shown potential medicinal applications, such as NITD609, that



**Figure 5:** Drugs and biologically active compounds bearing a 2-oxindole skeleton.

shows antimalarial activity [40] and satavaptan, a selective V2-receptor antagonist that is useful for the treatment of cirrhosis (Figure 5) [41,42]. Additionally, methisazone is a 2-oxindole derivative that has been used as antiviral drug, especially for the prophylactic treatment of small-pox since 1965 [43] and citrinadins A and B have shown activity against murine leukaemia and human epidermoid carcinoma [44], while PF1270 A, B and C act as histamine H3 receptor ligands and, consequently, can be of therapeutic interest to treat diabetes, obesity and central nervous system disorders [45]. Besides, several hybrid molecules containing, inter alia the oxindole moiety, have been discovered and they demonstrated diverse therapeutic activities, for example, against breast [46] and colon cancer cells [47] and drug-resistant bacteria [48].

Among the many excellent recent reviews on the preparation of heterocycles by multicomponent reactions (MCRs) [49-55], the

synthesis of three- and four-membered heterocycles through MCRs has been reviewed recently [56], and taking into account the increasing amount of procedures developed in the last years for the preparation of heterocycles [57,58] with interest in medicinal chemistry [59], such as those devoted to the synthesis of 5-membered  $\gamma$ -lactam heterocycles by means of multicomponent protocols [60], we believe that this field also deserves an in-depth revision that would benefit the researchers working in the synthesis of heterocycles. Especially interesting are the applications of these MCRs [61-64] in combinatorial chemistry [65] and diversity-oriented synthesis [66], where structurally diverse compound libraries can be rapidly synthesized.

Therefore, this article reviews the procedures disclosed recently for the multicomponent synthesis of isoindolinones **II** and 2-oxindoles **III** (Figure 1), where the setup of the  $\gamma$ -lactam core takes place during the key process.

MCRs involve the simultaneous reaction between three or more reactants to deliver products that include significant fragments of all the substrates in their structure. Those starting materials must be added all together in the reaction container and, therefore, other approaches [67–69] featuring sequential (domino, tandem or cascade) [70,71] reactions, where one intermediate is initially preformed before additional reagents are added, are not included in this review.

## Review

### Isoindolinones

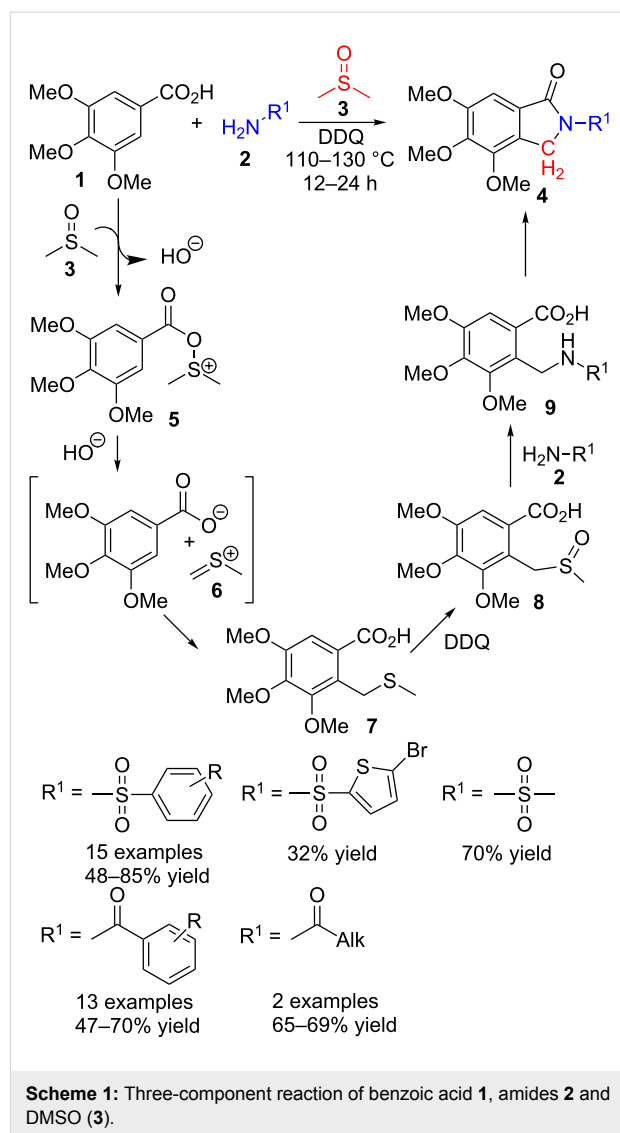
An extensive range of synthetic methods have been developed for the preparation of isoindolinone derivatives [72–75], although only a few make use of multicomponent approaches.

Most of the multicomponent syntheses of this type of heterocycles employ a benzoic acid derivative as one of the substrates of the reaction, together with an amine and a third reagent that provides the carbon atom needed to complete the cyclic moiety.

Thus, Shi et al. [76] reacted benzoic acid derivatives **1**, amides **2** and DMSO (**3**) in the presence of DDQ as oxidant and without any metal catalyst. Through a tandem three-component cross-dehydrogenative coupling (CDC), they prepared, in a single step, more than thirty isoindolinone derivatives **4**, including those originated from sulfonamides and carboxamides (Scheme 1). The scope of the reaction includes aromatic, some aliphatic and one heteroaromatic derivative with yields ranging from moderate to good. It is remarkable that no catalysts are needed in this transformation. Unfortunately, other aromatic acids bearing substituents different from three methoxy groups did not produce any detectable amounts of isoindolinone.

Based on several additional experiments, the authors propose a tentative mechanism based on a Pummerer-type rearrangement. First, dimethyl sulfoxide (**3**) and carboxylic acid **1** combine to render ester **5** that decomposes, giving a thionium derivative of DMSO (**6**, Scheme 1). This electrophilic derivative would react with the nucleophilic aromatic ring in a Friedel–Crafts alkylation process, thus incorporating the carbon atom in a formal  $C(sp^2)\text{--}H/C(sp^3)\text{--}H$  cross-dehydrogenative coupling. Finally, an oxidation of sulfide **7** to sulfoxide **8** and the subsequent attack of amide **2** with cleavage of the C–S bond and formation of **9**, followed by an intramolecular cyclic amide formation, would produce isoindolinone derivatives **4**.

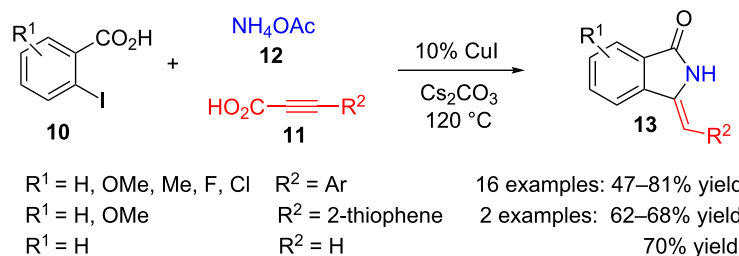
Employing benzoic acids **10** *ortho*-substituted with iodine along with alkynylcarboxylic acids **11** and ammonium acetate (**12**), in the presence of caesium carbonate and copper iodide as catalyst (10%), a series of 3-methyleneisoindolin-1-ones **13** were obtained (Scheme 2) [77]. Several aromatic and heteroaromatic



substituents can be introduced in the exocyclic methylene position with high regioselectivity. It is noteworthy that arylalkynyl-carboxylic acids **11** ( $R^2 = \text{Ar}$ ) can be obtained easily by the coupling reaction of propiolic acid and aryl halides [78].

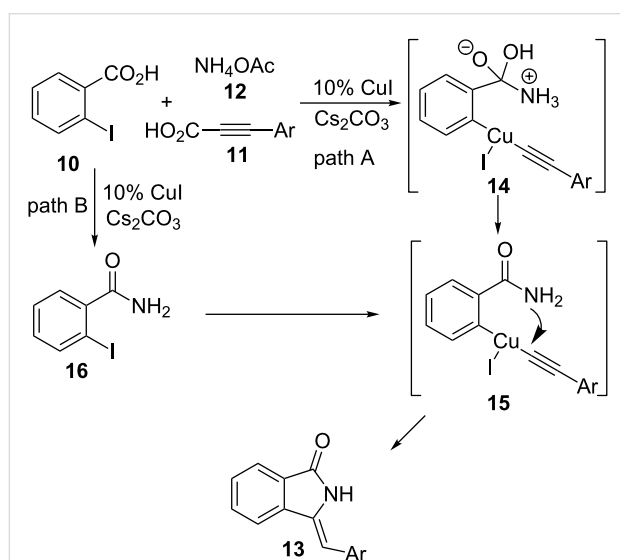
Furthermore, the authors have been able to carry out the reaction in a sequential manner starting from propiolic acid and aryl iodides in the presence of caesium carbonate and a palladium catalyst. Next, addition of 2-iodobenzoic acid and ammonium acetate leads to the formation of isoindolinone derivative **13** in 55–65% global yields, without isolating any intermediate.

Regarding the reaction mechanism, the authors have ruled out that phthalide must be an intermediate of the reaction and they proposed the two pathways illustrated in Scheme 3. In the first one (path A), decarboxylative coupling to form intermediates **14** and **15**, followed by a cyclization take place, while in the



**Scheme 2:** Copper-catalysed three-component reaction of 2-iodobenzoic acids **10**, alkynylcarboxylic acids **11** and ammonium acetate (**12**).

second path (B), the first step seems to be the formation of amide **16**.



**Scheme 3:** Proposed mechanism for the formation of methylene isoindolinones **13**.

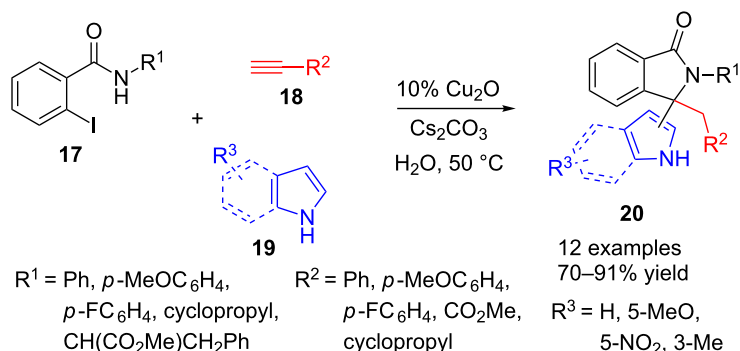
Indeed, another multicomponent approach to isoindolinones uses iodobenzamides **17** as starting materials (Scheme 4). In this case, copper catalyst and alkynes are also used but, unlike

the above method, alkynes **18** are monosubstituted. The third component is an indole or pyrrole derivative **19** and the result of the reaction is a 3,3-disubstituted isoindolinone derivative **20**, which contains a newly formed quaternary centre [79].

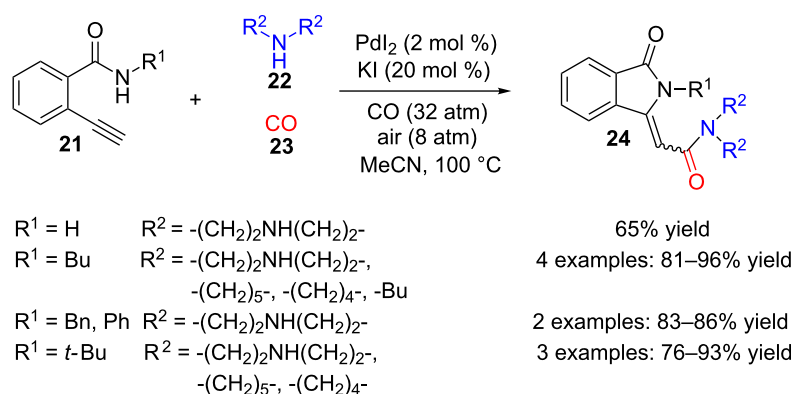
The reaction takes place in water, even in the presence of air, and with nanodomain cuprous oxide as an inexpensive and reusable catalyst. The scope includes aryl, alkyl and carboxyl groups at 2- and 3-positions of the lactam ring. Pyrrole reacts across the 2-carbon while indole derivatives do it through the carbon at 3-position. Although a quaternary stereocentre is created in the process, no attempts to make this synthesis in a stereoselective fashion were reported.

A tentative mechanism is proposed, based in a Sonogashira coupling of iodobenzamide **17** and copper acetylide, in a similar way to that described in Scheme 3. In this case, the coupled alkyne moiety is again activated by Cu(I) and then base-promoted cyclization occurs. A new copper complex formation with the alkene analogue to **13** (see Scheme 3) facilitates the aromatic nucleophilic substitution by indole or pyrrole, leading to final lactams **20**.

This mechanism is partially corroborated by the following multicomponent synthesis where benzamide **21**, *ortho*-functionalized with a terminal alkyne group (Scheme 5), a secondary



**Scheme 4:** Copper-catalysed three-component reaction of 2-iodobenzamide **17**, terminal alkyne **18** and pyrrole or indole derivatives **19**.



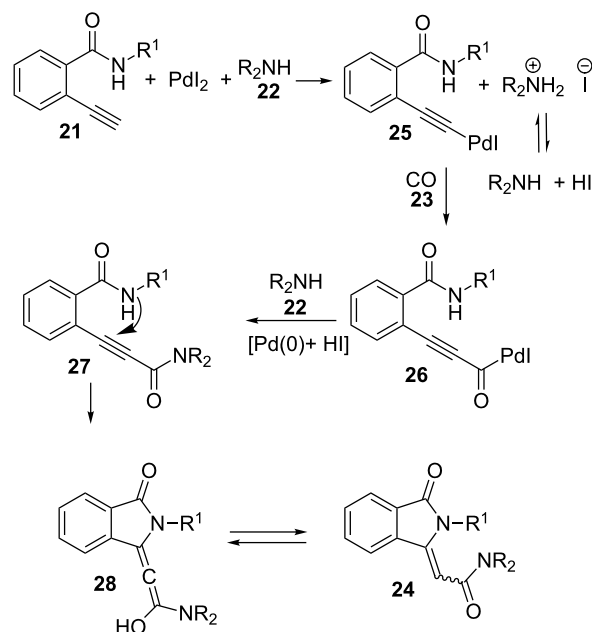
**Scheme 5:** Palladium-catalysed three-component reaction of ethynylbenzamides **21**, secondary amines **22** and CO (**23**).

amine **22** and carbon monoxide (**23**) react to produce 3-methyleneisoindolinones **24** [80]. A palladium catalyst in acetonitrile, and a high pressure of both, CO and air, are needed in order to perform an oxidative carbonylation on 2-ethynylbenzamide **21**.

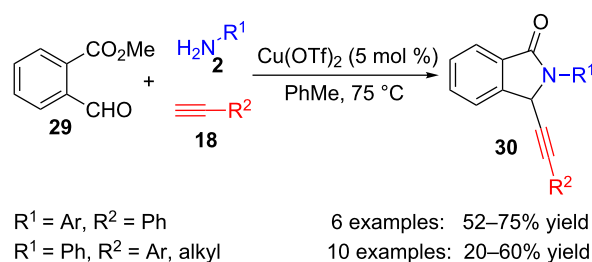
Up to ten compounds were obtained with yields ranging from 65 to 96%. Butyl, phenyl, benzyl or absence of substitution on the amide nitrogen produced, in most of the cases, the *Z*-isomer as the sole or main product, while *tert*-butyl derivatives gave the *E*-isomer selectively. On the secondary amine side, morpholine, piperidine, pyrrolidine and dibutylamine all rendered the reaction efficiently.

A plausible explanation for the mechanism of this transformation implies initial formation of an alkynylpalladium intermediate **25** followed by carbonylation to render acylpalladium **26** (Scheme 6). Reductive substitution of palladium by amine **22** furnishes diamide derivative **27** and Pd(0), which is reoxidized to Pd(II) again by HI and oxygen. Then, intramolecular conjugate addition of benzamide nitrogen onto the 2-ynamide generates the final cyclization product **24** through allene intermediate **28**. Taking into account that the reaction does not take place with internal alkynes, the authors conclude that a terminal alkyne is necessary for the formation of the first alkynylpalladium complex **25** in the proposed pathway.

Other benzoic acid derivatives such as those bearing a formyl substituent at the *ortho* position also take part in several multi-component cyclizations leading to isoindolinones. Thus, 2-formylbenzoate **29**, primary amines **2** and terminal alkynes **18** react under copper catalysis to furnish several propargylisoindolinones **30** with modest to good yields (Scheme 7) [81]. Although aryl- and alkylacetylenes can be used in this method, only aromatic amines **2** which are not *ortho*-substituted work well under these reaction conditions.



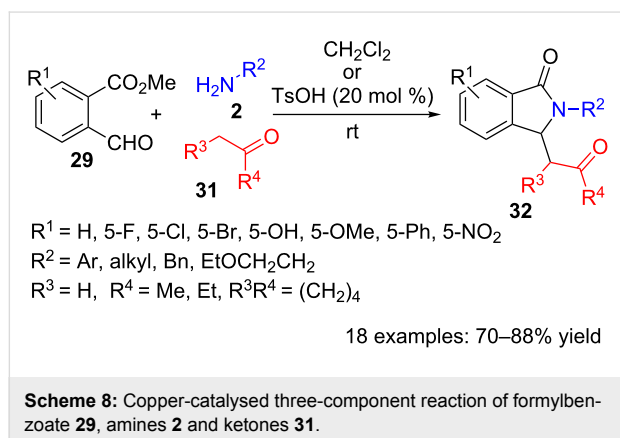
**Scheme 6:** Proposed mechanism for the formation of methyleneisoindolinones **24**.



**Scheme 7:** Copper-catalysed three-component reaction of formyl benzoate **29**, amines **2** and alkynes **18**.

The reaction probably takes place through an addition of copper acetylide, generated from terminal alkyne and copper, to the imine formed by the reaction between the amine and the formyl group. Then, the secondary propargylamine intermediate would act as a nucleophile in a cyclization process to form the lactam ring.

The same formylbenzoate **29** has also been used in another three-component synthesis along with amines **2** and ketones **31** (Scheme 8) [82]. This Mannich/lactamization reaction achieves good yields for a broad scope of 3-substituted isoindolinones **32**, in either catalyst-free conditions or using *p*-toluenesulfonic acid. *Ortho*- and *meta*-substituted anilines **2** did not produce isoindolinones **32**, and aliphatic amines only reacted when *p*-toluenesulfonic acid was present. The reaction has also been applied to 1,3-dicarbonyl compounds, however, only residual amounts of isoindolinones **32** were detected and deamination products became predominant.

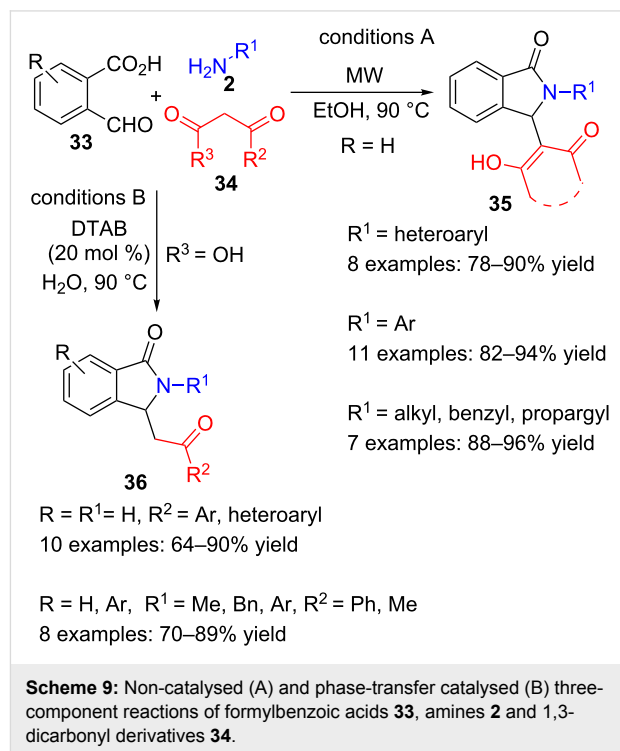


Similarly to the above mentioned method, the first step in this approach is probably the imine formation by reaction of amine **2** with the aldehyde functionality of benzoate **29**. Next, addition of the enol form of ketone **31** onto the imine would provide a Mannich intermediate amine, which can intramolecularly attack the ester function, giving rise to lactam **32**.

As pointed out above, unfortunately this methodology did not work properly when it was first applied to 1,3-dicarbonyl compounds. Nevertheless, more recently, two research groups have disclosed, nearly simultaneously, the three-component cyclization of 2-formylbenzoic acids, primary amines and a 1,3-dicarbonyl compounds.

The first proposal uses 2-formylbenzoic acid **33** ( $R = \text{H}$ , conditions A, Scheme 9), cyclic aliphatic and aromatic diketones **34** such as dimedone ( $R^2R^3 = -\text{CH}_2\text{CMe}_2\text{CH}_2-$ ) as the 1,3-dicarbonyl partner and a variety of aromatic, heteroaromatic and ali-

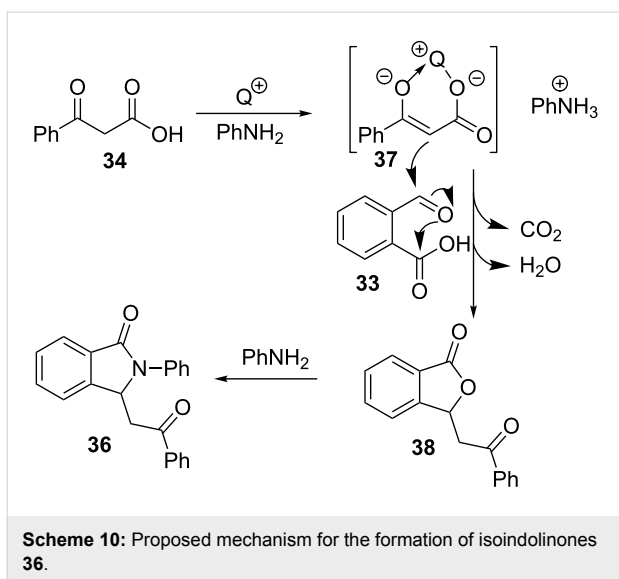
phatic amines in ethanol, under microwave heating, and without metal catalyst [83]. Very good yields of **35** are obtained in a very simple and cost-effective manner.



A rather similar approach was disclosed shortly later by Han and co-workers [84], who used  $\beta$ -ketoacids (**34**  $R^3 = \text{OH}$ , conditions B, Scheme 9) instead of diketones and a quaternary ammonium salt as catalyst in water. In this multicomponent decarboxylative alkylation/cyclization process, they prepared several lactam derivatives **36** with good yields.

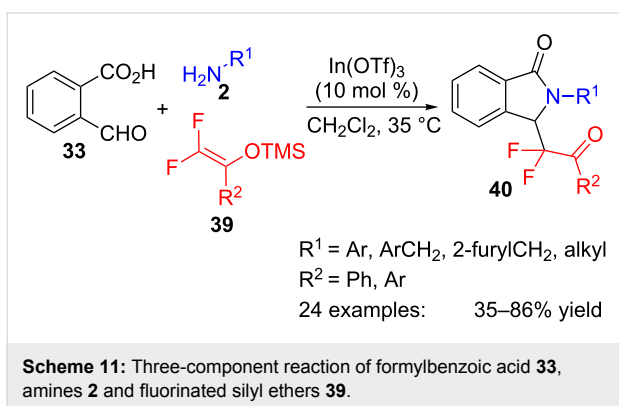
While the first research group suggests that the reaction would start with the formation of an imine intermediate between the aldehyde function of **33** and the amine **2**, followed by a nucleophilic attack by the diketone and a final intramolecular cyclization, the Han group proposes a different pathway, with an initial deprotonation of ketoacid **34** ( $R^2 = \text{Me, Ar, } R^3 = \text{OH}$ ) and a subsequent addition of enolate **37** onto the aldehyde moiety in **33**, with concomitant decarboxylation and cyclization to form a phthalide intermediate **38** (Scheme 10). Then, the known amine-substitution reaction would transform phthalide **38** into isoindolinone **36**.

A conceptually very similar procedure has been described by Singh and co-workers [85], who used formylbenzoate **29** and preformed enol ethers instead of ketones in a Mukaiyama–Mannich lactamization reaction catalysed by zinc or copper under mild conditions. A large amount of diverse iso-



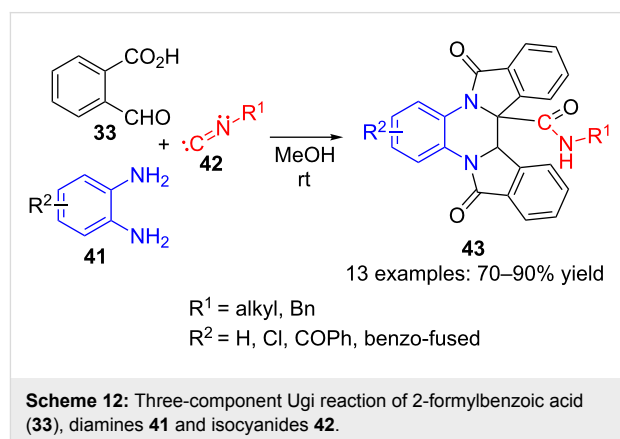
indolinones **32** (thirty-four examples) can be built in this manner, although, once again, *ortho*-substituted anilines **2** did not render the cyclic product, as the final lactamization step is probably impeded by sterical reasons. On the other hand, silyl enol ethers of acetone, acetophenone, methyl acetate, 2-hydroxyfuran and cyclohexanone worked well, providing isoindolinone **32** with yields ranging from 64 to 85%.

A variation of the above approach that makes use of fluorinated silyl ethers **39**, has been applied to the synthesis of analogous fluorinated isoindolinones **40** (Scheme 11) [86]. In this case, formylbenzoic acid **33**, a variety of aromatic, aliphatic and heteroaromatic amines **2** and trimethylsilyl enol ethers **39** are combined in a three-component Mannich/lactamization reaction in the presence of an indium catalyst to yield twenty four 3-difluoroalkylisoindolinone derivatives **40**.



The starting 2-formylbenzoic acid **33** has been also employed in Ugi-type multicomponent reactions with amines and isocyanides by several research groups to make highly functio-

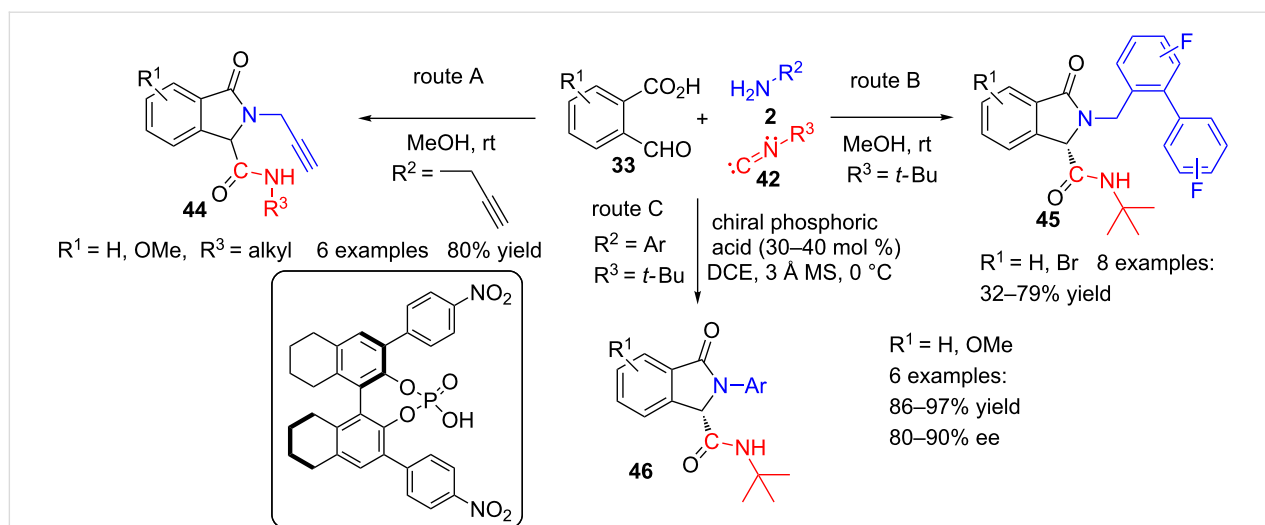
nalized lactams. After the pioneering works by Ley [87] and Zhang [88], other contributions have been reported in the last years. For example, Shaabani et al. [89] used diamines **41**, isocyanides **42** and two equivalents of 2-formylbenzoic acid (**33**) in an Ugi three-component reaction with methanol as solvent at room temperature to afford tetrahydroisoindoloquinolinecarboxamides **43** (Scheme 12).



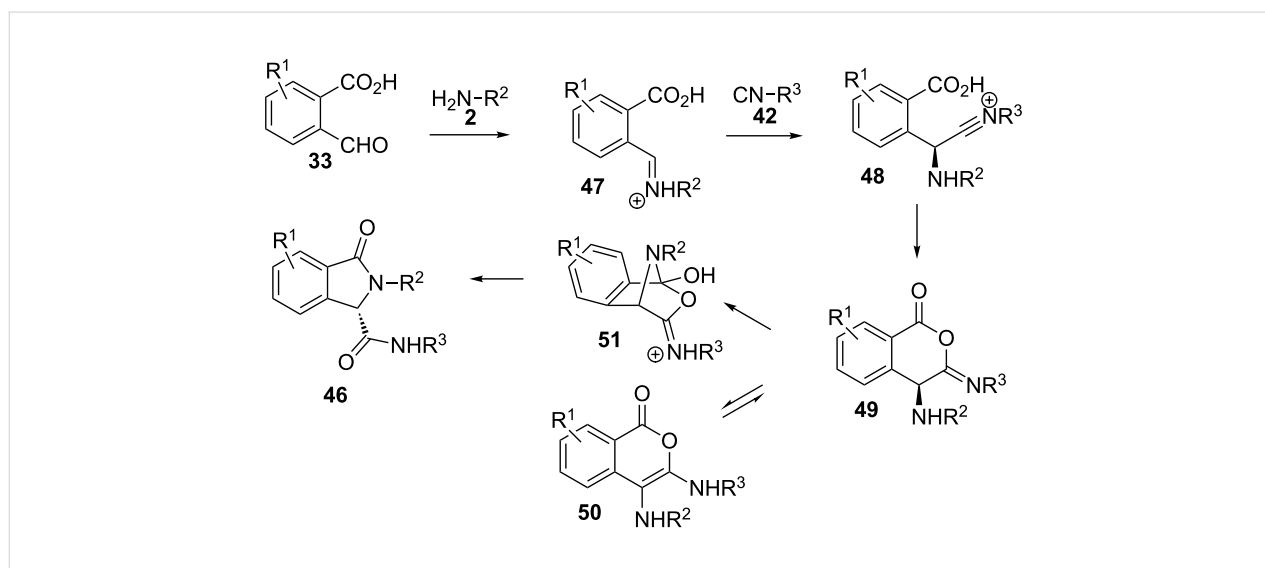
More recently, Shafiee et al. [90] utilized propargylamine as the cycle-nitrogen delivering component and then submitted the obtained isoindolinones **44** (route A, Scheme 13) to an additional cyclization to furnish a pyrazinoisoindole-dione derivative. Kajanus and co-workers [91] prepared eight isoindolinone derivatives **45** by this method with yields ranging from 32 to 79% (route B, Scheme 13).

They also made several analogues of these compounds by a sequential Ugi/Diels–Alder approach and, in this context, they were able to separate the enantiomers using chiral chromatography. Some of these compounds showed good *in vitro* potency blocking the cardiac ion channel Kv1.5 and, therefore, are promising agents to treat atrial fibrillation. Nevertheless, the most outstanding contribution is the first enantioselective Ugi synthesis of isoindolinones **46** catalysed by a chiral phosphoric acid, reported by D.-X. Wang, M.-X. Wang, J. Zhu and co-workers (route C, Scheme 13) [92]. They obtained very good yields and remarkable enantiomeric excesses, which result, according to the authors, from a dynamic kinetic resolution of the initially formed Ugi adduct.

Indeed, the plausible mechanism for the reaction implies the condensation of amine **2** and aldehyde **33** to form iminium salt intermediate **47** (Scheme 14). Next, addition of isocyanate **42** would supply the corresponding nitrilium intermediate **48**, which then can be trapped intramolecularly by the carboxylate moiety, thus furnishing isocumarine **49**. According to several control experiments performed by the authors, the imine **49**–en-



**Scheme 13:** Non-catalysed (A, B) and chiral phosphoric acid promoted (C) three-component Ugi reactions of formylbenzoic acids **33**, amines **2** and isocyanides **42**.



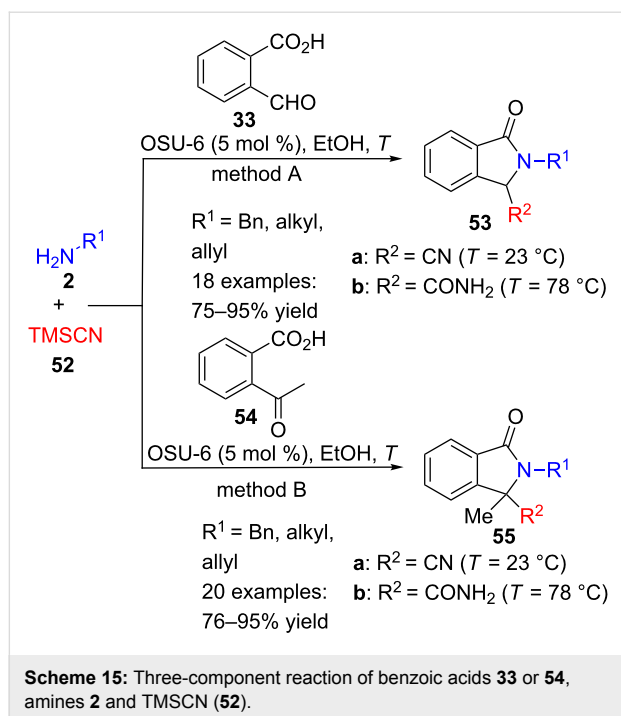
**Scheme 14:** Proposed mechanism for the enantioselective formation of isoindolinones **46**.

amine **50** tautomerization seems to happen faster than the Mumm rearrangement that would lead to isoindolinone **46** through the bridged intermediate **51**. Therefore, this mechanistic path shows that the enantioselectivity of the reaction is a consequence of a dynamic kinetic resolution of enamine **50**.

Cyanide can also be used, instead of isocyanide, in an analogous three-component reaction, to afford isoindolinones **53** substituted with nitrile or carboxamide groups (Scheme 15, method A) [93]. Trimethylsilylcyanide (**52**), and benzyl-, alkyl- and allylamines **2** were reacted with 2-formylbenzoic acid (**33**) in the presence of OSU-6, a mesoporous silica performing as a green Lewis acid catalyst for this transformation. At room tem-

perature, the product of this environmentally friendly Strecker reaction is nitrile derivative **53** ( $R^2 = \text{CN}$ , Scheme 15, method A), while at reflux carboxamide **53** ( $R^2 = \text{CONH}_2$ , Scheme 15, method A) is obtained. Notoriously, aromatic amines **2** did not work under these conditions and, in place of isoindolinones **53**, isobenzofuranones were isolated. The method was extended to the corresponding acetophenone derivative **54** and, in this case, quaternary nitriles and carboxamides **55** were prepared in good yields (Scheme 15, method B).

This Strecker approach has also been performed by using scandium catalyst ( $\text{Sc}(\text{OTf})_3$ , 2.5 mol %) and starting from ester **29**. Under these conditions, not only benzyl or alkyl, but also a

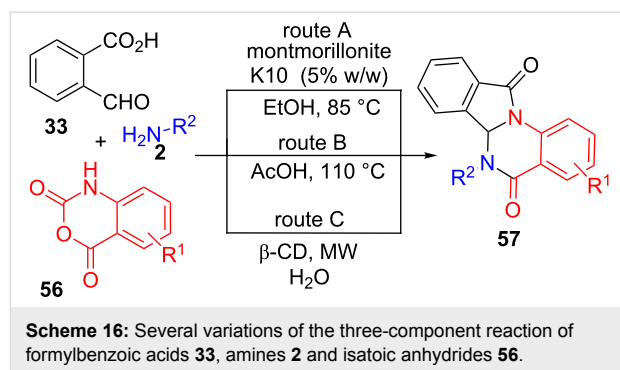


wide range of *ortho*-, *meta*- and *para*-arylamines **2** can be used at room temperature to make 3-oxoisindolinone-1-carbonitriles **53a** in very good yields (22 examples, 82–97% yields) [94].

On the contrary, another Strecker multicomponent synthesis, between 2-formylbenzoate **29**, benzylamine and potassium cyanide, carried out under mechanochemical conditions and zinc catalysis, only produced a 31% yield of the corresponding cyanoisindolinone **53a** (R<sup>1</sup> = Bn), along with 34% yield of benzyl phthalimide, probably formed by air oxidation of **53a** [95].

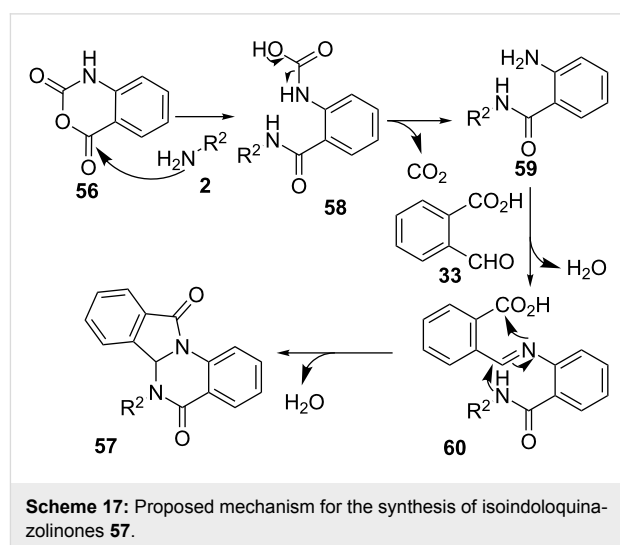
2-Formylbenzoic acid (**33**) has also been used in another type of three-component cyclization, along with amines **2** and isatoic anhydrides **56**, leading to isoindoloquinazolinone derivatives **57**, a kind of heterocycle containing five- and six-membered fused *N*-heterocyclic rings (Scheme 16), including the  $\gamma$ -lactam unit. The first synthesis of this class of compounds was reported by Pal et al. [96] with the aid of montmorillonite K10 as a recyclable catalyst in ethanol. With these environmentally friendly conditions, they reported the preparation of twelve analogues of **57** with good yields (72–95%, R<sup>1</sup> = H, R<sup>2</sup> = alkyl, benzyl, aryl) (route A, Scheme 16). Some of these molecules were able to inhibit tumour necrosis factor- $\alpha$  (TNF- $\alpha$ ) in vitro, therefore, showing potential medicinal applications.

A similar synthetic approach was applied by another research group, using acetic acid instead of ethanol as a solvent and



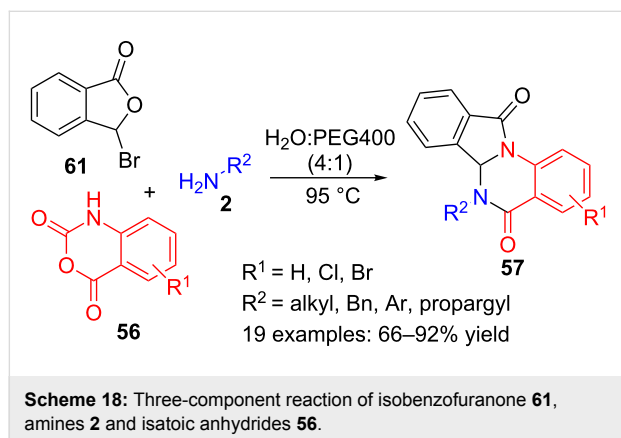
without any other catalyst (route B, Scheme 16) [97]. By this way, seventeen compounds of type **57** were obtained with yields ranging from 80 to 92% (R<sup>1</sup> = H, R<sup>2</sup> = H, alkyl, benzyl, aryl). Another improvement on this multicomponent approach, making use of  $\beta$ -cyclodextrine as promoter, water as a solvent, and microwave heating (route C, Scheme 16) [98]. Under these neutral conditions, they prepared up to nineteen compounds (60–95%, R<sup>1</sup> = H, Cl, R<sup>2</sup> = alkyl, benzyl, aryl), including two derivatives containing chlorine atoms in the portion coming from isatoic anhydride **56**.

In all cases, the most likely mechanism is initiated by a nucleophilic attack of amine **2** onto the anhydride carbonyl with opening of the cycle to form carbamic acid derivative **58** and loss of CO<sub>2</sub> to give the intermediate 2-aminobenzamide **59** (Scheme 17). Condensation with the aldehyde function in **33**, would originate imine intermediate **60**, which then takes part in an intramolecular double cyclization to furnish the final heterocyclic substrate **57**.

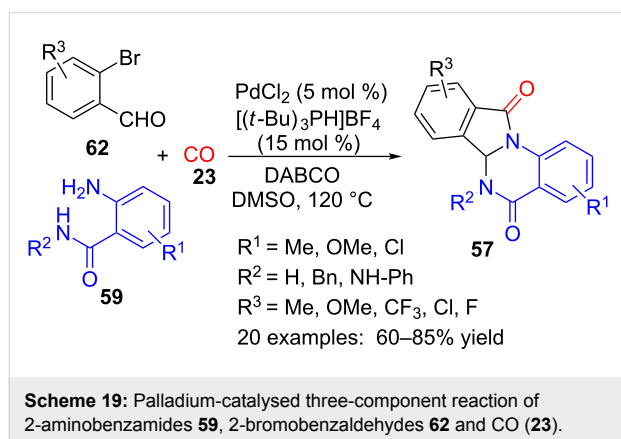


A variation of the previous procedure has been disclosed, where 2-formylbenzoic acid (**33**) is replaced by bromoisobenzofura-

none **61**, also leading to isoindoloquinazoline derivatives **57** (Scheme 18) [99]. After optimization of the reaction conditions, a 4:1 combination of water and PEG-400 was chosen as the best solvent and an array of nineteen isoindoloquinazolinones **57** with yields ranging from 66 to 92% was prepared. The mechanism is presumably very similar to that of the above reaction (Scheme 17), where isobenzofuranone **61** plays the role of formylbenzoic acid **33**.

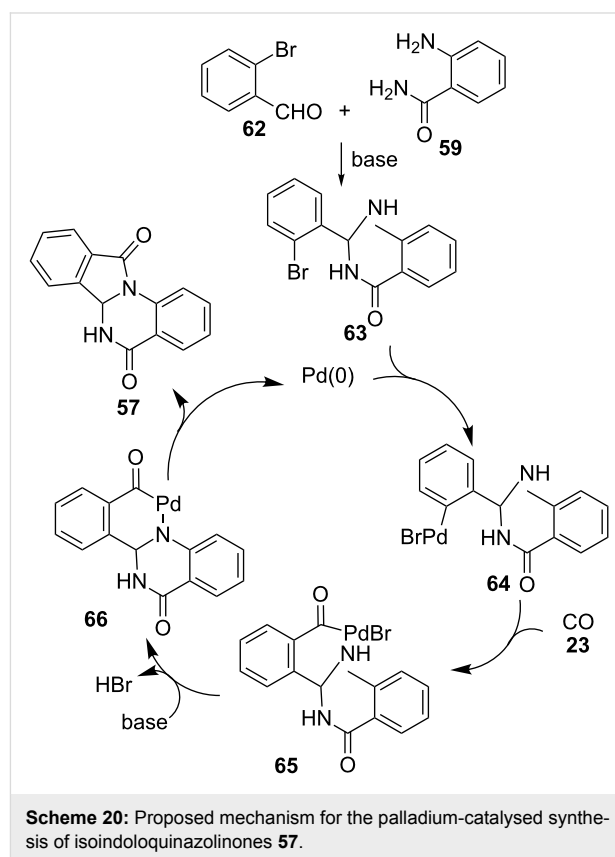


Another multicomponent approach to isoindoloquinazolinones **57** is the palladium-catalysed reaction of 2-aminoamides **59**, 2-bromobenzaldehydes **62** and carbon monoxide (**23**) at atmospheric pressure, with the assistance of DABCO as base and tri(*tert*-butyl)phosphonium tetrafluoroborate as ligand (Scheme 19) [100].



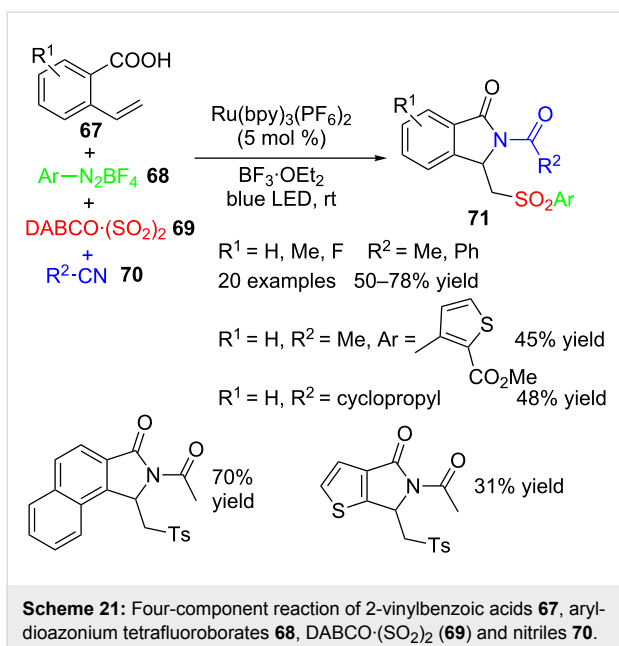
A variety of substituents in the benzene rings (R<sup>1</sup>, R<sup>3</sup>) are compatible with the reaction conditions, but heteroaromatic analogues of aldehyde **62**, such as 2-bromonicotinaldehyde or 2-bromothiophene-3-carbaldehyde did not produce the desired product. On the other hand, 2-aminoquinoline-3-carboxamide also reacted under these conditions to produce the corresponding isoindoloquinazolinone analogue of **57**.

Some control experiments allowed the authors to propose the mechanism as follows (Scheme 20). First, cyclocondensation of 2-aminoamide (**59**) with 2-bromobenzaldehyde (**62**) to form intermediate **63** is followed by oxidative addition of Pd(0) to provide palladium complex **64**. Then, insertion of CO (**23**) in the C–Pd bond furnishes an acylpalladium complex **65**, which, after elimination of hydrogen bromide and subsequent reductive elimination of palladium from intermediate **66**, affords **57** with regeneration of Pd(0).

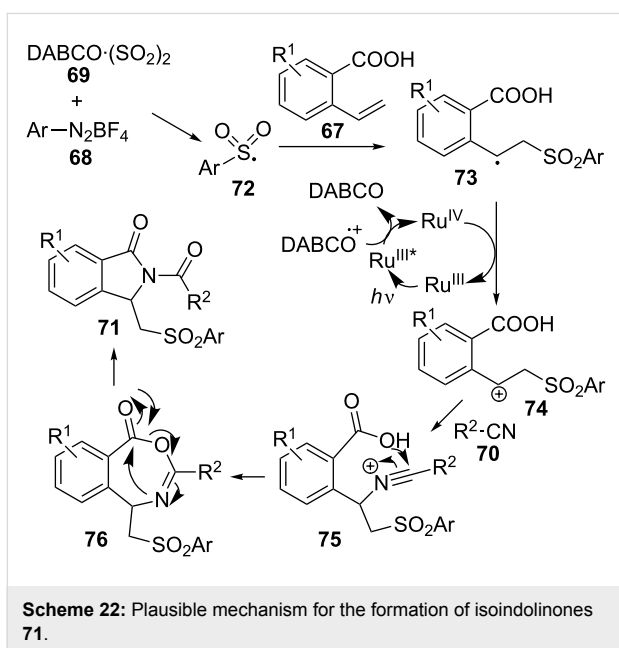


2-Vinylbenzoic acids **67** are also appropriate substrates for the preparation of isoindolinones **71** through a four-component reaction with aryldiazonium tetrafluoroborates **68**, DABCO-(SO<sub>2</sub>)<sub>2</sub> (**69**) and nitriles **70** under Ru(IV) photocatalysis with visible light and in the presence of a Lewis acid (Scheme 21) [101].

Up to 24 isoindolinone derivatives were obtained, bearing a wide variety of aryl moieties at the sulfonyl group, including a thiophene derivative. With the aid of several dedicated experiments, the researchers proposed a mechanism initiated by the formation of an arylsulfonyl radical **72**, which then would add to the alkene moiety in **67** to produce a radical intermediate **73** (Scheme 22). The photocatalyst-assisted oxidation of this radical would give rise to the corresponding cation **74**, which

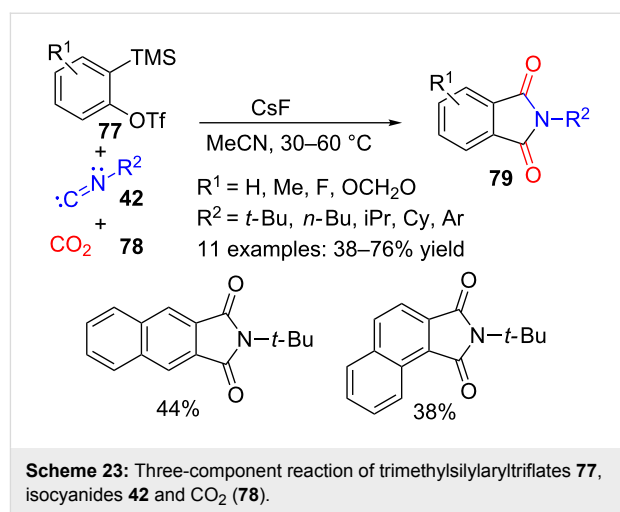


would add to the nucleophilic nitrile **70**. Intramolecular nucleophilic attack of the carboxy group in **75** followed by rearrangement of intermediate **76** delivered isoindolinone derivatives **71**.

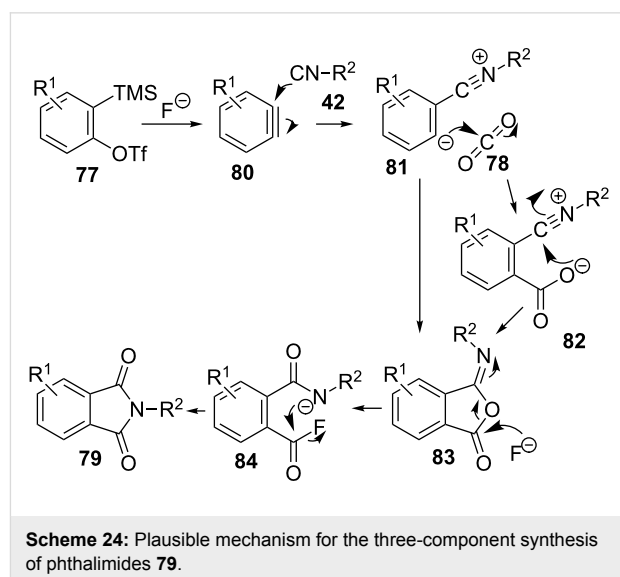


*Ortho*-functionalized benzoic acids have also been prepared in situ and used for a three-component transition-metal-free synthesis of phthalimides **79** induced by fluoride (Scheme 23) [102]. The reaction makes use of 2-(trimethylsilyl)aryl triflates **77**, isocyanides **42** and CO<sub>2</sub> (**78**), and takes place in acetonitrile as solvent and without the need of any transition metal. Different symmetrically and unsymmetrically substituted aryne pre-

cursors **77** and alkyl and aryl isocyanides **42** produced thirteen benzamide derivatives **79**, with moderate to good yields.

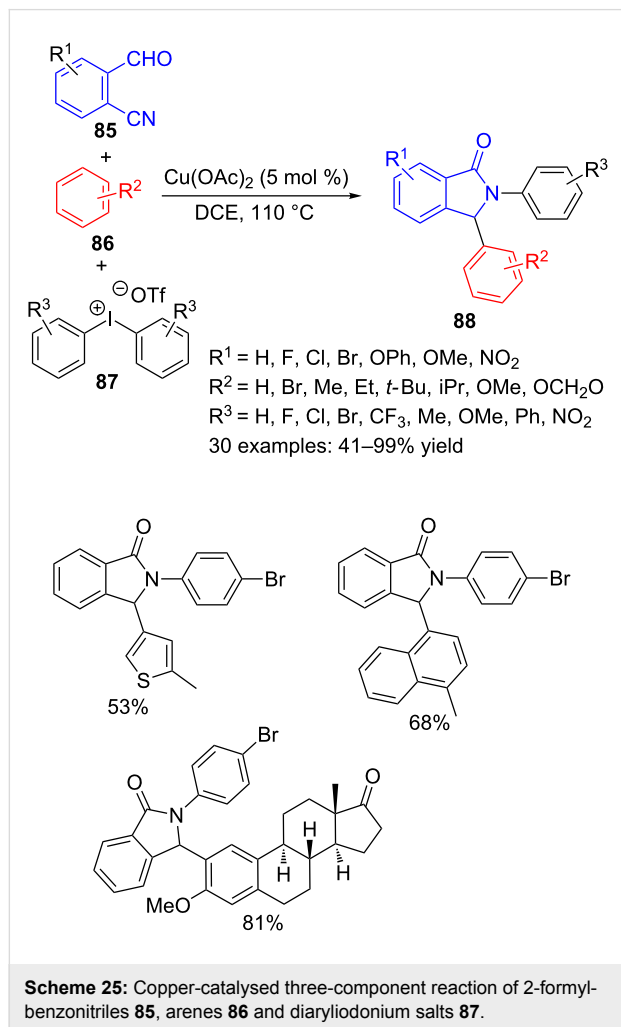


The plausible mechanism for this transformation (Scheme 24) would start with the formation of the reactive aryne **80** which is first trapped with the nucleophilic isocyanide to form **81** and then with the electrophilic CO<sub>2</sub> (**78**), to furnish an intermediate benzoic acid derivative **82**. Intramolecular cyclization would produce the corresponding isobenzofurane **83**, which alternatively, could also be formed by a concerted pathway. Then the fluoride induced ring opening and subsequent cyclization of intermediate **84** would generate phthalimide **79**.



Although most multicomponent reactions leading to isoindolinones make use of benzoic acid derivatives as one of the starting components, in a few contributions aromatic aldehyde, imine or nitrile compounds have been used instead.

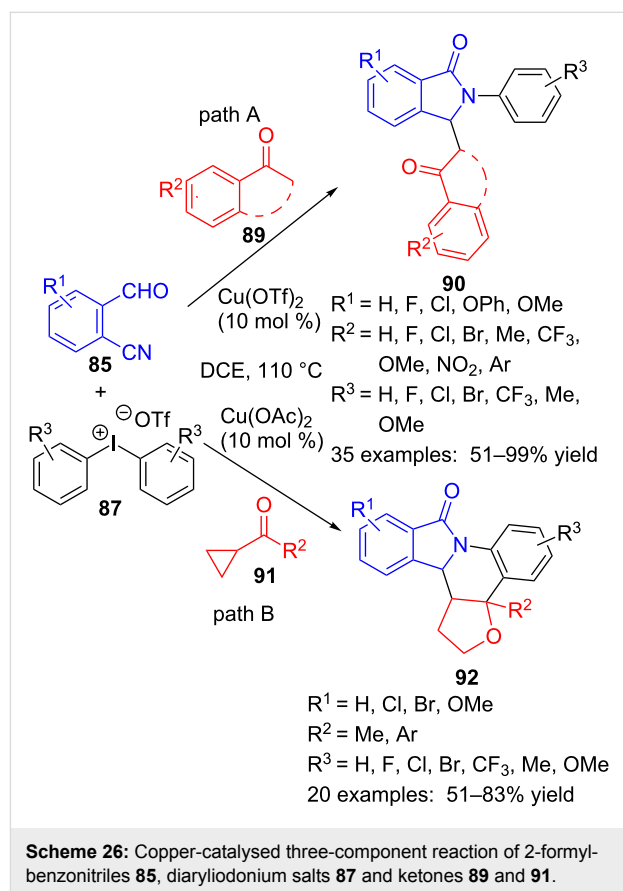
For instance, 2-formylbenzonitriles **85** along with a variety of arenes **86** and diaryliodonium salts **87**, combined in a copper-catalysed three-component cyclization produce 2,3-diarylisoin-dolinones **88** [103] (Scheme 25).



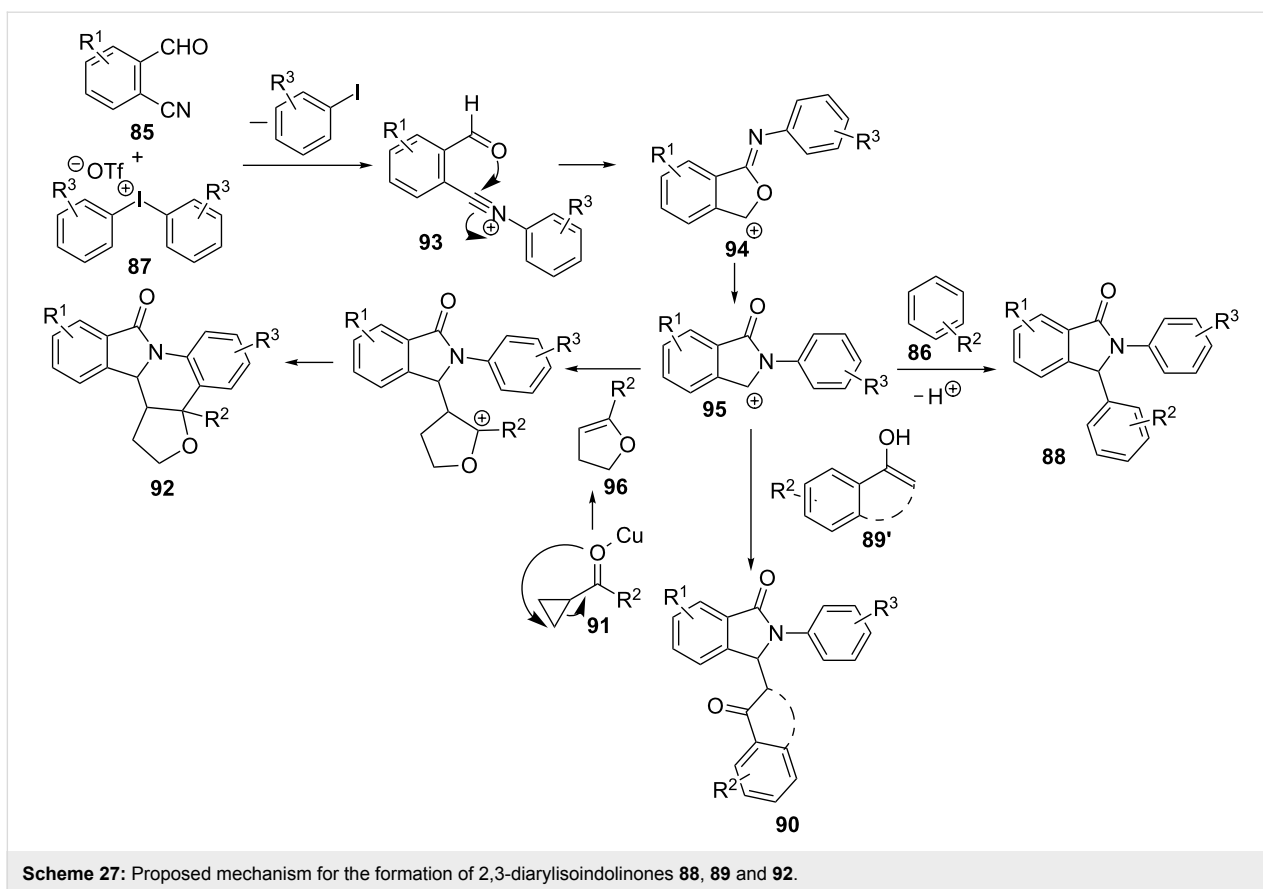
The scope of the reaction is very wide, since the three components have demonstrated the ability to be efficient sources of diversity in this reaction. Indeed, 33 isoindolinones **88** were prepared with yields ranging from moderate to very good. Even when unsymmetrical diaryliodonium salts **87** were used, the reaction was chemoselective, furnishing in good yields the products resulting from the transfer of the less hindered arene. However, this methodology exhibits two main limitations. First, arenes **86** with electron-withdrawing groups did not react under the optimized conditions and on the other hand, the atom economy is quite low, since a half of the diaryliodonium salt **87** is lost in the process.

Replacing the arene substrate **86** by ketones, and keeping nearly equal reaction conditions, the same authors have achieved an

efficient synthesis of 3-(2-oxopropyl)- or pentacyclic isoindolinones **90** or **92** (Scheme 26). Starting from several aryl and aliphatic ketones **89**, more than thirty isoindolinones **90** were obtained, with three points of diversity around the lactam core. Overall, aryl ketones containing electron-donating and electron-withdrawing functions and even a heteroaryl group delivered better yields than dialkyl ones (Scheme 26, path A) [104]. When cyclopropyl ketones **91** were used as substrates, a ring expansion and a new quaternary centre formation happened through the multicomponent reaction to produce pentacyclic derivatives **92** (Scheme 26, path B) [105].



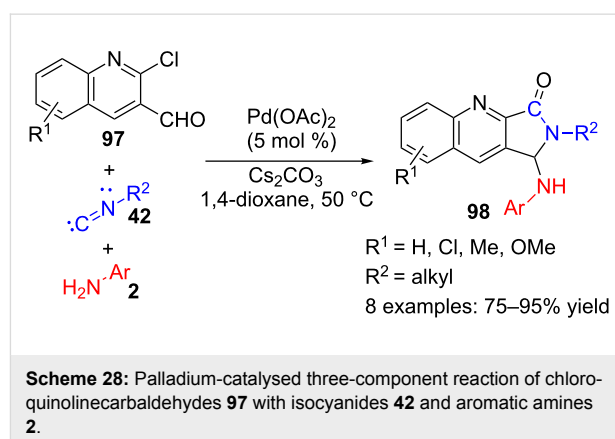
These reactions, either with arenes **86** or ketones **89** and **91**, seem to happen through an *N*-aryl nitrilium cation intermediate **93**, resulting from the reaction between formylbenzonitrile **85** and diaryliodonium salt **87** (Scheme 27). Intramolecular nucleophilic attack of the carbonyl group onto the nitrilium species would furnish cyclic intermediate **94**, that rearranges to afford cationic isoindolinone moiety **95**. Then, benzene derivative **86** would react by a Friedel–Crafts type reaction to form diaryl  $\gamma$ -lactam **88**. When ketone **89** is used instead of arene **86**, the enol form would act as nucleophile and upon reaction with carbocation **95**, compounds **90** could be isolated. Finally, cyclopropyl ketone **91** would first rearrange by copper catalysis and



the so-obtained furane derivative **96** would add to the carbocation in **95**, followed by Friedel–Crafts cyclization, thus generating the polycyclic isoindolinones **92** in a formal hetero [4 + 2] cycloaddition process.

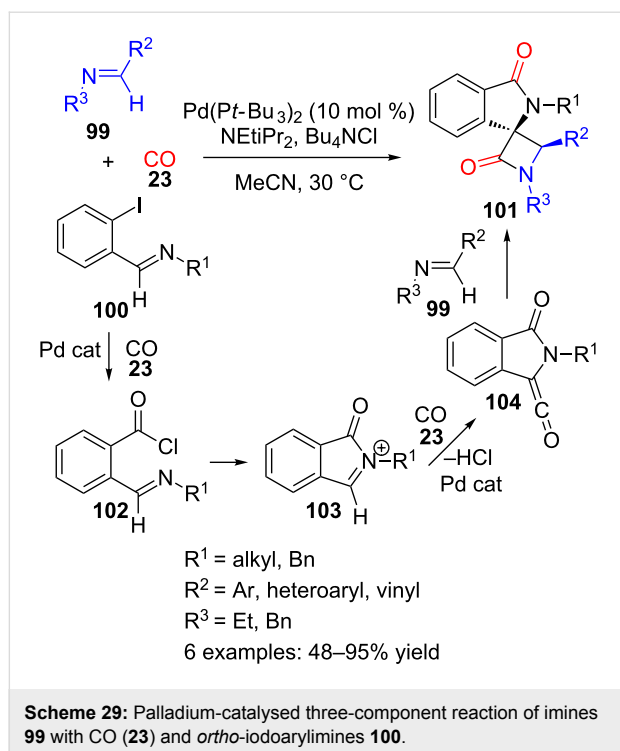
Another aromatic aldehyde, in this case derived from a quinoline, can also be used as substrate for a multicomponent reaction, appropriate for the preparation of 3-aminoisoindolinone analogues **98** (Scheme 28) [106]. Indeed, the reaction of chloroquinolinecarbaldehydes **97** with isocyanides **42** and aromatic amines **2**, catalysed by Pd, produced a small collection (8 examples, 75–95% yield) of quinoline derivatives **98** containing a  $\gamma$ -lactam moiety with different substituents at the nitrogen of the 5-membered ring and in the  $\gamma$ -position. Although the authors do not suggest a mechanism, this probably starts with the formation of an imine by reaction of aromatic amine **2** with quinolinecarbaldehyde **97**.

Certainly this is a quite feasible hypothesis, since it has been reported that *ortho*-iodo-substituted arylimines **100**, analogues of quinolinecarbaldehyde **97**, also reacted, under Pd catalysis, with CO (**23**) and imines **99** to furnish complex spirocyclic  $\gamma$ -lactams **101** (Scheme 29) [107]. These products show a *trans* orientation of the benzene moiety in the isoindolinone and the substituent



ent in  $R^2$ , according to NOE experiments and crystal structure analysis.

The proposed mechanism involves an initial palladium-catalysed carbonylation of iodoarylimine **100** to produce acid chloride **102** (Scheme 29). Intramolecular nucleophilic attack of the imine onto the acyl chloride would furnish cyclic *N*-acyliminium derivative **103**, which can then undergo a second palladium-catalysed carbonylation to form a stabilized ketene **104**. This is a good partner for a cycloaddition with an imine such as



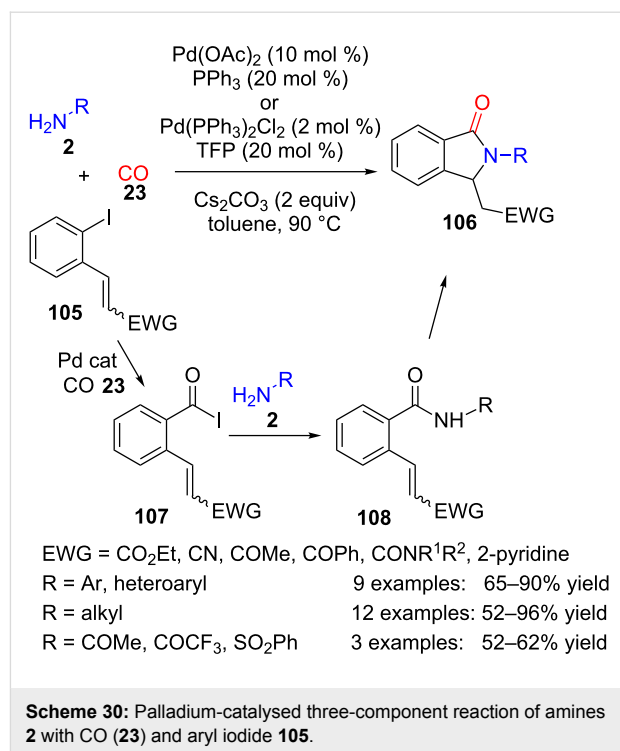
**99** that would give rise to the spiro  $\beta$ - and  $\gamma$ -lactam derivative **101** in a diastereoselective manner.

Indeed, a seminal contribution also made use of a similar Pd-catalysed carbonylation followed by amide formation and cyclization in a three-component reaction between aryl iodides, incorporating a Michael acceptor **105**, amines and amides **2** and carbon monoxide (**23**) (Scheme 30) [108].

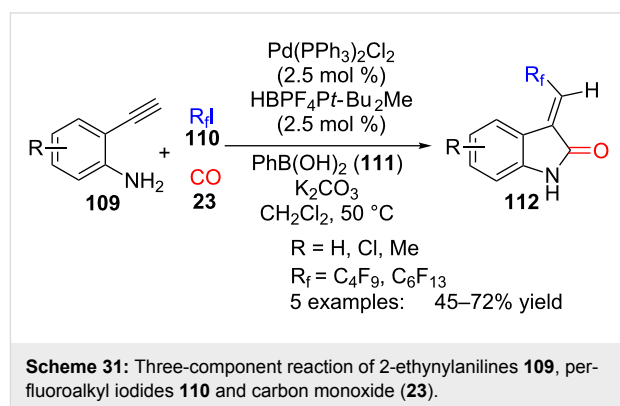
It is remarkable that not only aromatic but also aliphatic amines and even amides and sulfonamides can be used as the nitrogen-containing substrate. With chiral amines, very low diastereoselectivity was obtained, probably due to the harsh reaction conditions employed. In addition to carbonyl and carboxyl derivatives, pyridine was also used successfully as an electron-withdrawing group (EWG) in the Michael acceptor **105**. A simple control experiment allowed the authors to propose that the first stage of the reaction would be the insertion of carbon monoxide into the Ar–I bond to produce aryl iodide **107**, followed by the reaction with the nitrogen nucleophile to form amide intermediate **108**. Finally, intramolecular Michael addition would furnish lactam unit **106**.

## Oxindoles

The simplest protocol for the multicomponent assembly of oxindole heterocycles is the palladium-catalysed reaction involving carbon monoxide, in addition to terminal alkynes, arylboronic acids and alkyl iodides, which has been applied to the

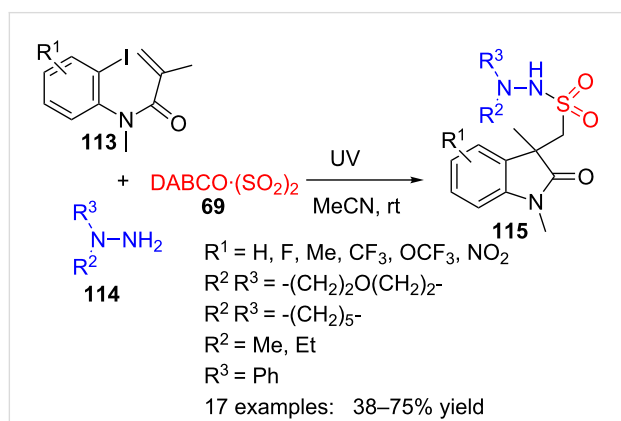


preparation of fluorinated 3-methyleneoxindole derivatives (Scheme 31) [109]. In this three-component reaction, 2-ethynylanilines **109** reacted with carbon monoxide (**23**) and perfluoroalkyl iodides **110**, in the presence of Pd(II) and phenylboronic acid (**111**), by means of an intramolecular amino-carbonylation reaction. Although phenylboronic acid did not incorporate into the final product structure, it was necessary for the reaction to take place. Using this protocol five oxindole derivatives **112** were synthesized with moderate yields, including one substrate containing a <sup>13</sup>C-labelled carbon, suitable to be used as a metabolic tracer.



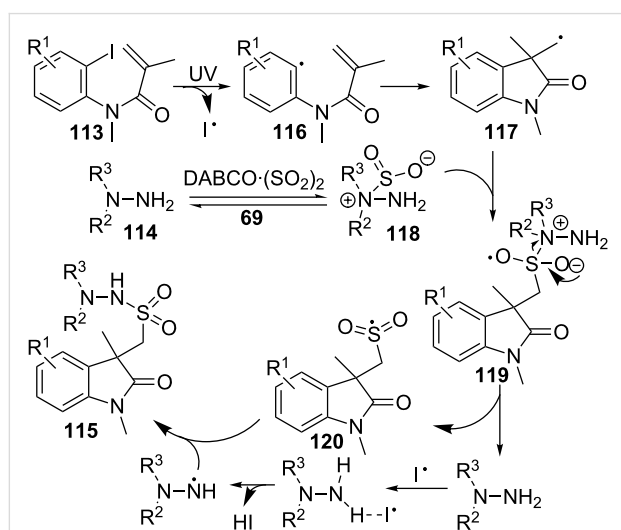
Nevertheless, most of the known multicomponent methods for the preparation of 2-oxindoles are based on the use of *N*-aryl amides as the main partner of the reagent pool.

Wu et al. reacted *N*-(2-iodoaryl)acrylamides **113**, DABCO·(SO<sub>2</sub>)<sub>2</sub> (**69**, also known as DABSO) as a surrogate of sulfur dioxide and hydrazine **114** in a photoinduced, catalyst-free three-component reaction (Scheme 32) [110]. In this way, a variety of (2-oxindolin-3-yl)methanesulfonylhydrazides **115** with diverse substituents in the aromatic ring and hydrazine nitrogen, were prepared with moderate to good yields.



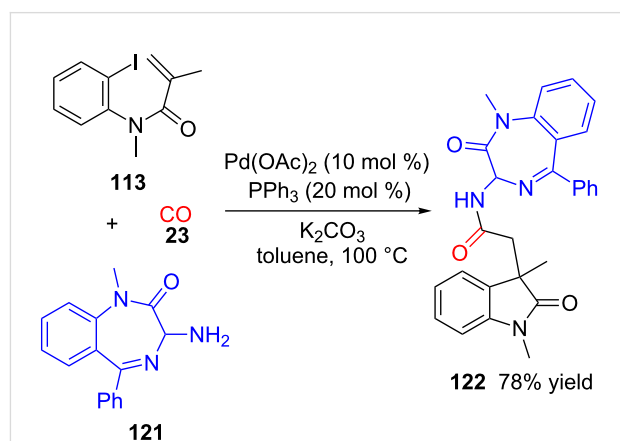
**Scheme 32:** Ultraviolet-induced three-component reaction of *N*-(2-iodoaryl)acrylamides **113**, DABCO·(SO<sub>2</sub>)<sub>2</sub> (**69**) and hydrazines **114**.

This transformation may be explained by a radical process promoted by UV irradiation, with an initial formation of aryl radical **116** from the corresponding aryl iodide **113** (Scheme 33). This radical would cyclize in an intramolecular 5-*exo* mode to furnish cyclic radical **117** which, in turn, can be caught by intermediate **118**, formed by hydrazine **114** and sulfur dioxide (Scheme 33). Rearrangement of the so-obtained intermediate **119**, through radical **120**, would provide oxindole **115**.



**Scheme 33:** Proposed mechanism for the preparation of oxindoles **115**.

The same acrylamide **113** ( $R^1 = \text{H}$ ) has been recently used in another multicomponent synthesis along with CO (**23**) and benzodiazepine derivative **121** under palladium catalysis to give a 1:1 mixture of diastereoisomers of oxindole **122** with good yield (Scheme 34) [111]. In this case, the process consists in a palladium-catalysed cyclization followed by a carbonylation and anion capture.

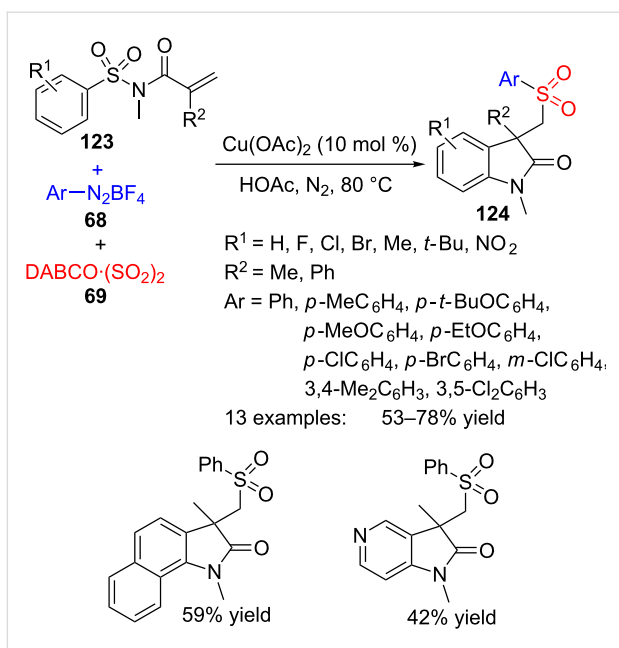


**Scheme 34:** Three-component reaction of acrylamide **113**, CO (**23**) and 1,4-benzodiazepine **121**.

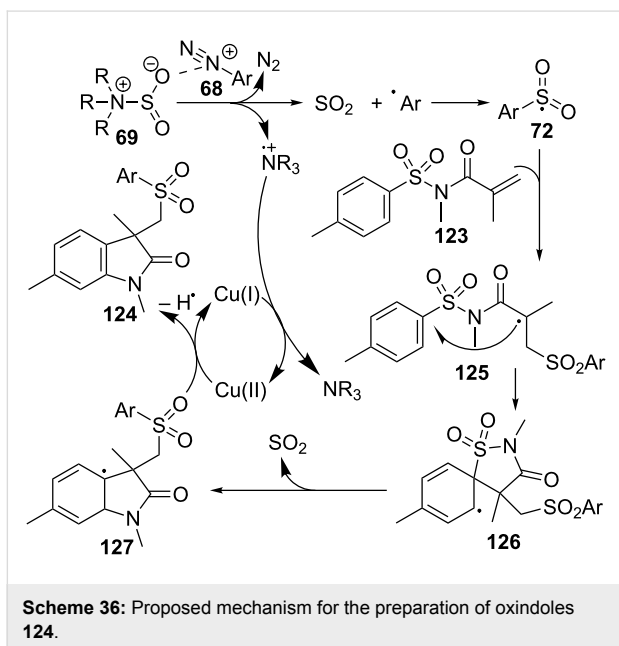
Several analogues of (2-oxindolin-3-yl)methanesulfonylhydrazides **115** have been prepared by another type of three-component approach, in this case under copper catalysis (Scheme 35) [112]. The partners of the reaction are *N*-(arylsulfonyl)acrylamides **123**, aryldiazonium tetrafluoroborates **68** and DABCO·(SO<sub>2</sub>)<sub>2</sub> (**69**), as a source of sulfur dioxide. In this way, sulfonated oxindoles **124** are prepared in moderate to good yields.

A wide scope of aryldiazonium reagents **68** bearing electron-donating and electron-withdrawing groups worked well in the reaction, but when a pyridyl heterocycle was employed, the reaction failed. On the acrylamide side, activating and deactivating groups worked similarly well and even a *N*-heteroaryl analogue of **124** was obtained, although the yield was moderate (42%).

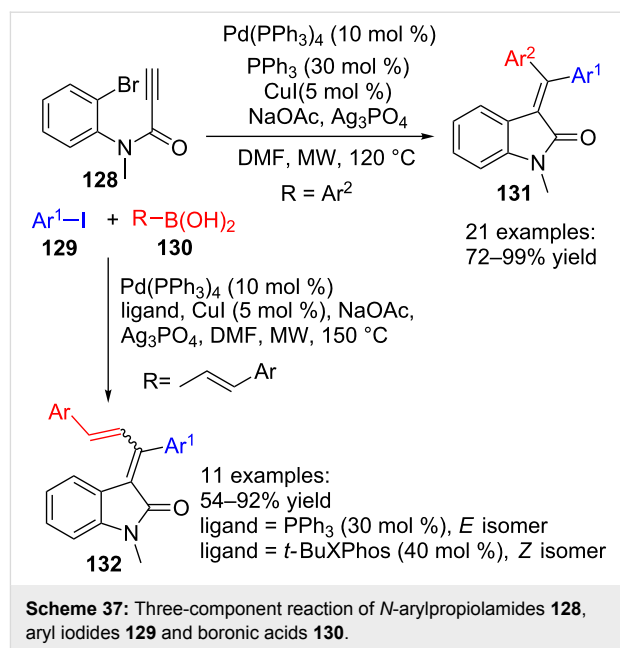
The formation of compound **124** may be explained by a radical process, starting with the addition of arylsulfonyl radical **72**, formed from **69** and aryldiazonium cation **68**, onto the alkene moiety of sulfonylacrylamide **123** (Scheme 36). Then, ipso-cyclization of radical **125** to **126**, departure of SO<sub>2</sub> and final oxidation of **127** by Cu(II) would provide oxindole **124**. As a consequence of this desulfonylative 1,4-aryl migration, the SO<sub>2</sub> group initially present in the starting acrylamide is replaced by another SO<sub>2</sub> moiety coming from the DABCO·(SO<sub>2</sub>)<sub>2</sub> reagent.



**Scheme 35:** Multicomponent reaction of sulfonylacrylamides **123**, aryl diazonium tetrafluoroborates **68** and DABCO·(SO<sub>2</sub>)<sub>2</sub> (**69**).



Other analogues of acrylamides that are appropriate substrates for oxindole preparation using multicomponent protocols are *N*-arylpropiolamides. This approach has been reported by Seo and co-workers in a series of papers that develop a three-component transformation comprising three palladium-catalysed reactions: Sonogashira, Heck and Suzuki–Miyaura (Scheme 37) [113–115]. In this methodology, *N*-arylpropiolamides **128** reacted with aryl iodides **129** and aryl- or styrylboronic acids **130** under microwave activation to yield 3-(diaryl-



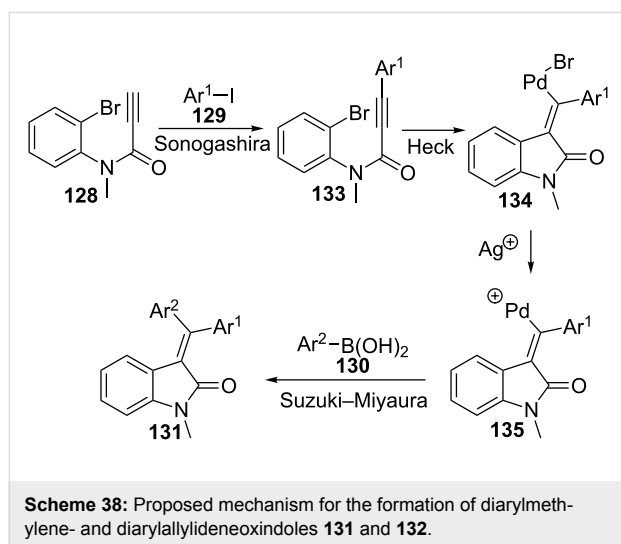
methylene)oxindoles **131** or 3-(1,3-diarylallylidene)oxindoles **132**, respectively.

Initially [114,115], using arylboronic acids **130** ( $R = \text{Ar}^2$ ), a variety of twenty-one diarylmethylene oxindoles **131** were obtained with good yields. When aryl iodide and arylboronic acids bearing different substituents are used, the expected stereochemistry of the asymmetric products **131** is mainly obtained, where the aromatic group coming from the boronic acid partner settles far from the carbonyl group. Methoxy, nitro, chloro and acetoxy groups of the aromatic moiety can be located at the *ortho*, *meta* and *para* positions, although 2-nitro derivatives gave low yields or no reaction in some cases. In addition to above mentioned benzene derivatives, heteroaromatic boronic acids also worked well under the reaction conditions and provided high yields of the corresponding oxindoles **131**. Finally, switching the *N*-substituent in the starting propiolamide **128** by a H or a Bn group, did not affect the yield of the reaction, although the stereoselectivities diminished.

Next [113], the authors applied the reaction conditions to the use of styrylboronic acids **130** ( $R = \text{CH=CHAr}$ ), and a collection of eleven 3-(1,3-diarylallylidene)oxindoles **132** were obtained with good yields and controlled stereochemistry (Scheme 37). Indeed, they found that the  $\text{PPh}_3$  ligand promoted the formation of the *E*-isomer as the main compound while the *t*-BuXPhos ligand induced the preferential formation of the *Z*-isomer.

As already mentioned before, this transformation is the result of a sequence of three palladium-catalysed reactions (Scheme 38).

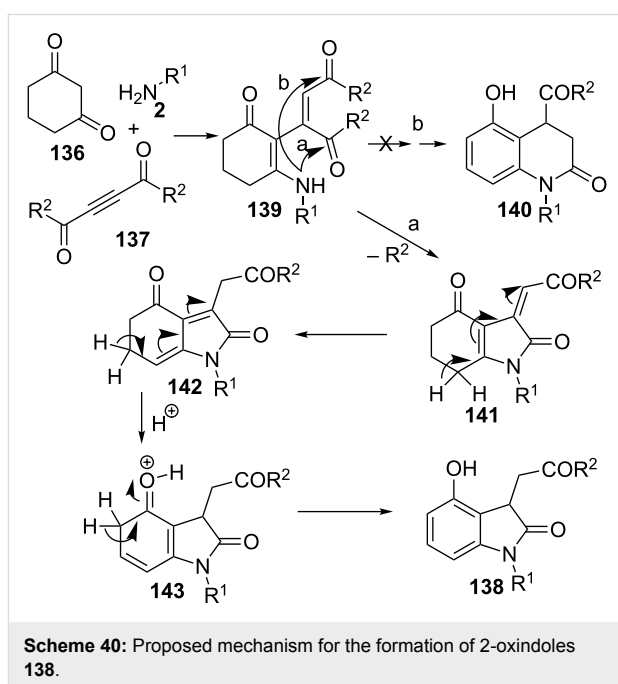
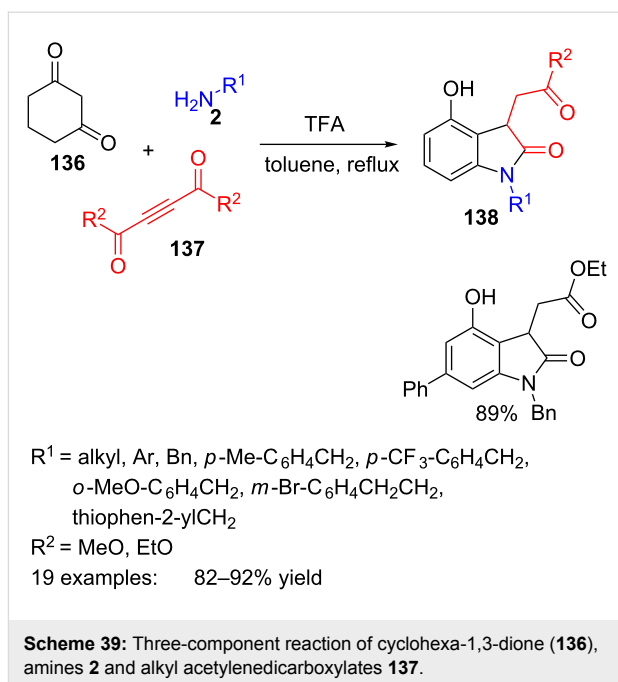
The first one is a Sonogashira coupling reaction between the terminal alkyne of propiolamide **128** and aryl iodide **129**, which is preferred to the Suzuki–Miyaura reaction between aryl iodide **129** and boronic acid **130** present in the reaction mixture. Then, an internal Heck cyclization reaction between the substituted alkyne and aryl bromide in **133** takes place to form a cyclic palladium intermediate **134** with *E*-configuration, resulting from a *syn*-addition mechanism of this step. The addition of a silver salt reduces the probability of isomerization of the double bond, presumably by changing the anionic character of the palladium complex to cationic in intermediate **135**. Finally, the Suzuki–Miyaura coupling of palladium salt **135** with boronic acid derivative **130** would provide the final oxindoles **131** or **132**.



Finally, it is worth mentioning an example of a multicomponent synthesis where the benzene moiety is created from non-aromatic substrates. Certainly, this three-component protocol includes an aromatization step in the course of the acid-catalysed reaction of cyclohexa-1,3-dione (**136**), amines **2** and alkyl acetylenedicarboxylates **137**, to produce the final phenolic oxindoles **138** with good yields (Scheme 39) [116].

Up to twenty different oxindole derivatives were prepared with any kind of substituents on the nitrogen atom, including aromatic, benzyl, heteroarylmethyl and alkyl groups.

According to some control experiments, the authors propose a plausible mechanism involving a sequential enamine formation–Michael addition to produce intermediate **139**, followed by intramolecular cyclization to **141** and aromatization through species **142** and **143** (Scheme 40). The cyclization step takes place in a regioselective manner, leading to five-membered heterocycle **141** rather than to the formation of six-membered



lactam **140**. Then, tautomerization followed by aromatization would provide oxindole **138**.

## Conclusion

Although the utilization of multicomponent reactions in synthesis is not a new deal, in the last years there has been an increased use of this strategy, particularly for the preparation of heterocyclic compounds. This is mainly due to the need to find new efficient methods in order to save raw materials and work

time. Without doubt, multicomponent approaches in chemical synthesis take the advantage of those two saving features. This economical profit is especially interesting for the large-scale synthesis in pharmaceutical laboratories and industry.

Nevertheless, among the multicomponent synthetic methods available for the preparation of isoindolinones **II** and 2-oxindoles **III**, only one is enantioselective, even though many of the reactions described in this review involve the generation of new chiral centres. This drawback needs to be addressed so that new ligands and organocatalysts can be discovered and applied to the synthesis of enantiomerically pure  $\gamma$ -lactams of this type under smooth and environmentally more benign reaction conditions.

Another area of improvement is the need to more methods for the multicomponent building of the oxindole core, since the few approaches now available depart from complex starting materials. Therefore, it would be highly desirable to develop new protocols in order to increase the structural diversity of oxindole derivatives to be made using simple substrates and reagents.

## Acknowledgements

Financial support by Ministerio de Economía, Industria y Competitividad (MINECO, CTQ-2015-67871R) and Gobierno Vasco (GV, IT 992-16) is gratefully acknowledged.

## ORCID® iDs

Edorta Martínez de Marigorta - <https://orcid.org/0000-0002-1167-0240>

Jesús M. de Los Santos - <https://orcid.org/0000-0003-1315-4263>

Ana M. Ochoa de Retana - <https://orcid.org/0000-0002-8700-5394>

Javier Vicario - <https://orcid.org/0000-0002-8976-0991>

Francisco Palacios - <https://orcid.org/0000-0001-6365-0324>

## References

- Caruano, J.; Muccioli, G. G.; Robiette, R. *Org. Biomol. Chem.* **2016**, *14*, 10134–10156. doi:10.1039/c6ob01349j
- Speck, K.; Magauer, T. *Beilstein J. Org. Chem.* **2013**, *9*, 2048–2078. doi:10.3762/bjoc.9.243
- Sanchez, J. F.; Entwistle, R.; Corcoran, D.; Oakley, B. R.; Wang, C. C. *Med. Chem. Commun.* **2012**, *3*, 997–1002. doi:10.1039/c2md20055d
- Yang, X.-L.; Zhang, S.; Hu, Q.-B.; Luo, D.-Q.; Zhang, Y. *J. Antibiot.* **2011**, *64*, 723–727. doi:10.1038/ja.2011.82
- Moreau, A.; Couture, A.; Deniau, E.; Grandclaude, P.; Lebrun, S. *Org. Biomol. Chem.* **2005**, *3*, 2305–2309. doi:10.1039/b504602e
- Min, J.-Y.; Kim, G. *J. Org. Chem.* **2014**, *79*, 1444–1448. doi:10.1021/jo402345q
- Valencia, E.; Freyer, A. J.; Shamma, M.; Fajardo, V. *Tetrahedron Lett.* **1984**, *25*, 599–602. doi:10.1016/s0040-4039(00)99948-9
- Li, J. C.; Li, G. P. M.; Yang, J. H.; Dai, Y.; Duan, Y. X.; Zhang, J. S. *Asian J. Chem.* **2012**, *24*, 2815–2816.
- Kamauchi, H.; Shiraiishi, Y.; Kojima, A.; Kawazoe, N.; Kinoshita, K.; Koyama, K. *J. Nat. Prod.* **2018**, *81*, 1290–1294. doi:10.1021/acs.jnatprod.7b00976
- Kaur, M.; Singh, M.; Chadha, N.; Silakari, O. *Eur. J. Med. Chem.* **2016**, *123*, 858–894. doi:10.1016/j.ejmech.2016.08.011
- Zhang, H.-p.; Kamano, Y.; Ichihara, Y.; Kizu, H.; Komiyama, K.; Ito, H.; Pettit, G. R. *Tetrahedron* **1995**, *51*, 5523–5528. doi:10.1016/0040-4020(95)00241-y
- De, S.; Das, M. K.; Bhunia, S.; Bisai, A. *Org. Lett.* **2015**, *17*, 5922–5925. doi:10.1021/acs.orglett.5b03082 and references cited therein.
- Balk-Bindseil, W.; Helmke, E.; Weyland, H.; Laatsch, H. *Liebigs Ann.* **1995**, 1291–1294. doi:10.1002/jlac.1995199507171
- Cui, C. B.; Kakeya, H.; Osada, H. *J. Antibiot.* **1996**, *49*, 832–835. doi:10.7164/antibiotics.49.832
- Takahashi, I.; Kawakami, T.; Hirano, E.; Yokota, H.; Kitajima, H. *Synlett* **1996**, 353–355. doi:10.1055/s-1996-5438
- Sorbera, L. A.; Leeson, P. A.; Silvestre, J.; Castañer, J. *Drugs Future* **2001**, *26*, 651–657. doi:10.1358/dof.2001.026.07.630003
- Uemura, S.; Fujita, T.; Sakaguchi, Y.; Kumamoto, E. *Biochem. Biophys. Res. Commun.* **2012**, *418*, 695–700. doi:10.1016/j.bbrc.2012.01.080 and references cited therein.
- Badros, A. Z. *N. Engl. J. Med.* **2012**, *366*, 1836–1838. doi:10.1056/nejme1202819
- Shin, H.-S.; Oh, J.-A. *J. Sep. Sci.* **2012**, *35*, 541–547. doi:10.1002/jssc.201100574
- Adachi, S.; Watanabe, K.; Iwata, Y.; Kameda, S.; Miyaoka, Y.; Onozuka, M.; Mitsui, R.; Saikawa, Y.; Nakata, M. *Angew. Chem., Int. Ed.* **2013**, *52*, 2087–2091. doi:10.1002/anie.201209205 and references cited therein.
- Riedinger, C.; Endicott, J. A.; Kemp, S. J.; Smyth, L. A.; Watson, A.; Valeur, E.; Golding, B. T.; Griffin, R. J.; Hardcastle, I. R.; Noble, M. E.; McDonnell, J. M. *J. Am. Chem. Soc.* **2008**, *130*, 16038–16044. doi:10.1021/ja8062088
- Comins, D. L.; Schilling, S.; Zhang, Y. *Org. Lett.* **2005**, *7*, 95–98. doi:10.1021/ol047824w
- Jagtap, P. G.; Southan, G. J.; Baloglu, E.; Ram, S.; Mabley, J. G.; Marton, A.; Salzman, A.; Szabó, C. *Bioorg. Med. Chem. Lett.* **2004**, *14*, 81–85. doi:10.1016/j.bmcl.2003.10.007
- Bhardwaj, A.; Kaur, J.; Sharma, S. K.; Huang, Z.; Wuest, F.; Knaus, E. E. *Bioorg. Med. Chem. Lett.* **2013**, *23*, 163–168. doi:10.1016/j.bmcl.2012.10.131
- Zhang, L.; Chen, X.; Liu, J.; Zhu, Q.; Leng, Y.; Luo, X.; Jiang, H.; Liu, H. *Eur. J. Med. Chem.* **2012**, *58*, 624–639. doi:10.1016/j.ejmech.2012.06.020
- MacSari, I.; Besidski, Y.; Csjerniyk, G.; Nilsson, L. I.; Sandberg, L.; Yngve, U.; Ahlin, K.; Bueters, T.; Eriksson, A. B.; Lund, P.-E.; Venyike, E.; Oerther, S.; Hygge Blakeman, K.; Luo, L.; Arvidsson, P. I. *J. Med. Chem.* **2012**, *55*, 6866–6880. doi:10.1021/jm300623u
- Dobrikov, G. M.; Valcheva, V.; Stoilova-Disheva, M.; Momekov, G.; Tzvetkova, P.; Chimov, A.; Dimitrov, V. *Eur. J. Med. Chem.* **2012**, *48*, 45–56. doi:10.1016/j.ejmech.2011.11.035
- Yoo, K.-D.; Park, E.-S.; Lim, Y.; Kang, S.-I.; Yoo, S.-H.; Won, H.-H.; Kim, Y.-H.; Yoo, I.-D.; Yoo, H.-S.; Hong, J. T.; Yun, Y.-P. *J. Pharmacol. Sci.* **2012**, *118*, 171–177. doi:10.1254/jpps.11159fp
- Temperini, C.; Cecchi, A.; Scozzafava, A.; Supuran, C. T. *J. Med. Chem.* **2009**, *52*, 322–328. doi:10.1021/jm801386n

30. Cai, S.-L.; Chen, Y.; Sun, W.-X.; Li, H.; Chen, Y.; Yuan, S.-S. *Bioorg. Med. Chem. Lett.* **2010**, *20*, 5649–5652. doi:10.1016/j.bmcl.2010.08.034
31. Cacabelos, R. *Int. J. Mol. Sci.* **2017**, *18*, No. 551. doi:10.3390/ijms18030551 and references cited therein.
32. Mazzei, M. E.; Richeldi, L.; Collard, H. R. *Ther. Adv. Respir. Dis.* **2015**, *9*, 121–129. doi:10.1177/1753465815579365
33. Emery, P.; Kong, S. X.; Ehrich, E. W.; Watson, D. J.; Towheed, T. E. *Clin. Ther.* **2002**, *24*, 1225–1291. doi:10.1016/s0149-2918(02)80033-9
34. Kauffman, R. F.; Robertson, D. W.; Franklin, R. B.; Sandusky, G. E., Jr.; Dies, F.; McNay, J. L.; Hayes, J. S. *Cardiovasc. Drug Rev.* **1990**, *8*, 303–322. doi:10.1111/j.1527-3466.1990.tb00398.x
35. Bethke, T.; Brunkhorst, D.; von der Leyen, H.; Meyer, W.; Nigbur, R.; Scholz, H. *Naunyn-Schmiedeberg's Arch. Pharmacol.* **1988**, *337*, 576–582. doi:10.1007/bf00182735
36. Nagamine, J.; Nagata, R.; Seki, H.; Nomura-Akimaru, N.; Ueki, Y.; Kumagai, K.; Taiji, M.; Noguchi, H. *J. Endocrinol.* **2001**, *171*, 481–489. doi:10.1677/joe.0.1710481
37. Faivre, S.; Demetri, G.; Sargent, W.; Raymond, E. *Nat. Rev. Drug Discovery* **2007**, *6*, 734–745. doi:10.1038/nrd2380
38. London, C. A.; Malpas, P. B.; Wood-Follis, S. L.; Boucher, J. F.; Rusk, A. W.; Rosenberg, M. P.; Henry, C. J.; Mitchener, K. L.; Klein, M. K.; Hintermeister, J. G.; Bergman, P. J.; Couto, G. C.; Mauldin, G. N.; Michels, G. M. *Clin. Cancer Res.* **2009**, *15*, 3856–3865. doi:10.1158/1078-0432.ccr-08-1860
39. Prakash, C. R.; Thevendren, P.; Raja, S. *Pharmacol. Pharm.* **2012**, *3*, 62–71. doi:10.4236/pp.2012.31010
40. Rottmann, M.; McNamara, C.; Yeung, B. K. S.; Lee, M. C. S.; Zou, B.; Russell, B.; Seitz, P.; Plouffe, D. M.; Dharia, N. V.; Tan, J.; Cohen, S. B.; Spencer, K. R.; Gonzalez-Paez, G. E.; Lakshminarayana, S. B.; Goh, A.; Suwanarusk, R.; Jegla, T.; Schmitt, E. K.; Beck, H.-P.; Brun, R.; Nosten, F.; Renia, L.; Dartois, V.; Keller, T. H.; Fidock, D. A.; Winzeler, E. A.; Diagona, T. T. *Science* **2010**, *329*, 1175–1180. doi:10.1126/science.1193225
41. Yan, L.; Xie, F.; Lu, J.; Ni, Q.; Shi, C.; Tang, C.; Yang, J. *BMC Gastroenterol.* **2015**, *15*, No. 65. doi:10.1186/s12876-015-0297-z
42. Izumi, Y.; Miura, K.; Iwao, H. *J. Pharmacol. Sci.* **2014**, *124*, 1–6. doi:10.1254/jphs.13r13cp
43. Augusto Ribeiro Do Valle, L.; Raposo De Melo, P.; Florêncio De Salles Gomes, L.; Morato Proença, L. *Lancet* **1965**, *286*, 976–978. doi:10.1016/s0140-6736(65)92840-0
44. Mugishima, T.; Tsuda, M.; Kasai, Y.; Ishiyama, H.; Fukushi, E.; Kawabata, J.; Watanabe, M.; Akao, K.; Kobayashi, J. *J. Org. Chem.* **2005**, *70*, 9430–9435. doi:10.1021/jo051499o and references cited therein.
45. Kushida, N.; Watanabe, N.; Okuda, T.; Yokoyama, F.; Gyobu, Y.; Yaguchi, T. *J. Antibiot.* **2007**, *60*, 667–673. doi:10.1038/ja.2007.85
46. Kaur, M.; Singh, P. *Bioorg. Med. Chem. Lett.* **2019**, *29*, 32–35. doi:10.1016/j.bmcl.2018.11.021
47. Tokala, R.; Thatikonda, S.; Vanteddu, U. S.; Sana, S.; Godugu, C.; Shankaraiah, N. *ChemMedChem* **2018**, *13*, 1909–1922. doi:10.1002/cmdc.201800402
48. Zhou, Y.; Ju, Y.; Yang, Y.; Sang, Z.; Wang, Z.; He, G.; Yang, T.; Luo, Y. *J. Antibiot.* **2018**, *71*, 887–897. doi:10.1038/s41429-018-0076-5
49. Zhang, J.; Yu, P.; Li, S.-Y.; Sun, H.; Xiang, S.-H.; Wang, J.; Houk, K. N.; Tan, B. *Science* **2018**, *361*, eaas8707. doi:10.1126/science.aas8707
50. Wang, Q.; Wang, D.-X.; Wang, M.-X.; Zhu, J. *Acc. Chem. Res.* **2018**, *51*, 1290–1300. doi:10.1021/acs.accounts.8b00105
51. Ibarra, I. A.; Islas-Jácome, A.; González-Zamora, E. *Org. Biomol. Chem.* **2018**, *16*, 1402–1418. doi:10.1039/c7ob02305g
52. Kazemizadeh, A. R.; Ramazani, A. *Curr. Org. Chem.* **2012**, *16*, 418–450. doi:10.2174/138527212799499868
53. van Berkel, S. S.; Bögels, B. G. M.; Wijdeven, M. A.; Westermann, B.; Rutjes, F. P. J. T. *Eur. J. Org. Chem.* **2012**, 3543–3559. doi:10.1002/ejoc.201200030
54. Hall, D. G.; Rybak, T.; Verdelet, T. *Acc. Chem. Res.* **2016**, *49*, 2489–2500. doi:10.1021/acs.accounts.6b00403
55. Sadjadi, S.; Heravi, M. M.; Nazari, N. *RSC Adv.* **2016**, *6*, 53203–53272. doi:10.1039/c6ra02143c
56. Rotstein, B. H.; Zaretsky, S.; Rai, V.; Yudin, A. K. *Chem. Rev.* **2014**, *114*, 8323–8359. doi:10.1021/cr400615v
57. Alonso, C.; Fuertes, M.; Martín-Encinas, E.; Selas, A.; Rubiales, G.; Tesouro, C.; Knudssen, B. K.; Palacios, F. *Eur. J. Med. Chem.* **2018**, *149*, 225–237. doi:10.1016/j.ejmech.2018.02.058
58. Alonso, C.; Martín-Encinas, E.; Rubiales, G.; Palacios, F. *Eur. J. Org. Chem.* **2017**, 2916–2924. doi:10.1002/ejoc.201700258
59. Ghashghaei, O.; Masdeu, C.; Alonso, C.; Palacios, F.; Lavilla, R. *Drug Discovery Today: Technol.* **2018**, *29*, 71–79. doi:10.1016/j.ddtec.2018.08.004
60. del Corte, X.; Maestro, A.; Vicario, J.; Martínez de Marigorta, E.; Palacios, F. *Org. Lett.* **2018**, *20*, 317–320. doi:10.1021/acs.orglett.7b03397
61. Zhu, J.; Wang, Q.; Wang, M.-X., Eds. *Multicomponent Reactions in Organic Synthesis*; Wiley-VCH: Weinheim, 2015. doi:10.1002/9783527678174
62. Marson, C. M. *Chem. Soc. Rev.* **2012**, *41*, 7712–7722. doi:10.1039/c2cs35183h
63. Dömling, A.; Wang, W.; Wang, K. *Chem. Rev.* **2012**, *112*, 3083–3135. doi:10.1021/cr100233r
64. de Graaff, C.; Ruijter, E.; Orru, R. V. A. *Chem. Soc. Rev.* **2012**, *41*, 3969–4009. doi:10.1039/c2cs15361k
65. Kshirsagar, T., Ed. *High-Throughput Lead Optimization in Drug Discovery in Critical Reviews in Combinatorial Chemistry*; CRC Press: Boca Raton, Florida, 2008.
66. Burke, M. D.; Schreiber, S. L. *Angew. Chem., Int. Ed.* **2004**, *43*, 46–58. doi:10.1002/anie.200300626
67. Bisai, V.; Unhale, R. A.; Suneja, A.; Dhanasekaran, S.; Singh, V. K. *Org. Lett.* **2015**, *17*, 2102–2105. doi:10.1021/acs.orglett.5b00676
68. Karmakar, R.; Suneja, A.; Bisai, V.; Singh, V. K. *Org. Lett.* **2015**, *17*, 5650–5653. doi:10.1021/acs.orglett.5b02932
69. Bisai, V.; Suneja, A.; Singh, V. K. *Angew. Chem., Int. Ed.* **2014**, *53*, 10737–10741. doi:10.1002/anie.201405074
70. Zeng, X.; Ni, Q.; Raabe, G.; Enders, D. *Angew. Chem., Int. Ed.* **2013**, *52*, 2977–2980. doi:10.1002/anie.201209581
71. Zeng, X. *Chem. Rev.* **2013**, *113*, 6864–6900. doi:10.1021/cr400082n
72. Alonso, C.; González, M.; Palacios, F.; Rubiales, G. *J. Org. Chem.* **2017**, *82*, 6379–6387. doi:10.1021/acs.joc.7b00977
73. Liu, L.; Qiang, J.; Bai, S.-H.; Sung, H.-L.; Miao, C.-B.; Li, J. *Adv. Synth. Catal.* **2017**, *359*, 1283–1289. doi:10.1002/adsc.201601403
74. Nozawa-Kumada, K.; Kadokawa, J.; Kameyama, T.; Kondo, Y. *Org. Lett.* **2015**, *17*, 4479–4481. doi:10.1021/acs.orglett.5b02235

75. Verma, A.; Patel, S.; Meenakshi, M.; Kumar, A.; Yadav, A.; Kumar, S.; Jana, S.; Sharma, S.; Prasad, C. D.; Kumar, S. *Chem. Commun.* **2015**, *51*, 1371–1374. doi:10.1039/c4cc08717h and references cited therein.
76. Wang, P.-M.; Pu, F.; Liu, K.-Y.; Li, C.-J.; Liu, Z.-W.; Shi, X.-Y.; Fan, J.; Yang, M.-Y.; Wei, J.-F. *Chem. – Eur. J.* **2016**, *22*, 6262–6267. doi:10.1002/chem.201600865
77. Irudayanathan, F. M.; Noh, J.; Choi, J.; Lee, S. *Adv. Synth. Catal.* **2014**, *356*, 3433–3442. doi:10.1002/adsc.201400451
78. Park, K.; Palani, T.; Pyo, A.; Lee, S. *Tetrahedron Lett.* **2012**, *53*, 733–737. doi:10.1016/j.tetlet.2011.11.117
79. Sarkar, S.; Chatterjee, N.; Roy, M.; Pal, R.; Sarkar, S.; Sen, A. K. *RSC Adv.* **2014**, *4*, 7024–7029. doi:10.1039/c3ra46168h
80. Mancuso, R.; Ziccarelli, I.; Armentano, D.; Marino, N.; Giofrè, S. V.; Gabriele, B. *J. Org. Chem.* **2014**, *79*, 3506–3518. doi:10.1021/jo500281h
81. Sun, L. X.; Zeng, T.; Jiang, D.; Dai, L.-Y.; Li, C.-J. *Can. J. Chem.* **2012**, *90*, 92–99. doi:10.1139/v11-108
82. Zhang, H.; Leng, Y.; Liu, W.; Duan, W. *Synth. Commun.* **2012**, *42*, 1115–1127. doi:10.1080/00397911.2010.535948
83. Sashidhara, K. V.; Singh, L. R.; Palnati, G. R.; Avula, S. R.; Kant, R. *Synlett* **2016**, *27*, 2384–2390. doi:10.1055/s-0035-1562614
84. Han, F.-Z.; Su, B.-B.; Jia, L.-N.; Wang, P.-W.; Hu, X.-P. *Adv. Synth. Catal.* **2017**, *359*, 146–152. doi:10.1002/adsc.201600944
85. Dhanasekaran, S.; Kayet, A.; Suneja, A.; Bisai, V.; Singh, V. K. *Org. Lett.* **2015**, *17*, 2780–2783. doi:10.1021/acs.orglett.5b01197
86. Chen, T.; Cai, C. *New J. Chem.* **2017**, *41*, 2519–2522. doi:10.1039/c6nj03813a
87. Ley, S. V.; Taylor, S. J. *Bioorg. Med. Chem. Lett.* **2002**, *12*, 1813–1816. doi:10.1016/s0960-894x(02)00269-x
88. Zhang, J.; Jacobson, A.; Rusche, J. R.; Herlihy, W. *J. Org. Chem.* **1999**, *64*, 1074–1076. doi:10.1021/jo982192a
89. Shaabani, A.; Hajjishaabhanha, F.; Mahyari, M.; Mofakham, H.; Ng, S. W. *Tetrahedron* **2011**, *67*, 8360–8366. doi:10.1016/j.tet.2011.08.061
90. Esmaili-Marandi, F.; Yavari, I.; Saeedi, M.; Mahdavi, M.; Shafiee, A. *Helv. Chim. Acta* **2016**, *99*, 187–190. doi:10.1002/hlca.201500168
91. Kajanus, J.; Jacobson, I.; Åstrand, A.; Olsson, R. I.; Gran, U.; Björe, A.; Fjellström, O.; Davidsson, Ö.; Emtenäs, H.; Dahlgren, A.; Löfberg, B.; Yuan, Z.-Q.; Sundell, J.; Cassel, J.; Gyll, J.; Iliefski, T.; Högberg, Å.; Lindhardt, E.; Malmberg, J. *Bioorg. Med. Chem. Lett.* **2016**, *26*, 2023–2029. doi:10.1016/j.bmcl.2016.02.081
92. Zhang, Y.; Ao, Y.-F.; Huang, Z.-T.; Wang, D.-X.; Wang, M.-X.; Zhu, J. *Angew. Chem., Int. Ed.* **2016**, *55*, 5282–5285. doi:10.1002/anie.201600751
93. Nammalwar, B.; Muddala, N. P.; Murie, M.; Bunce, R. A. *Green Chem.* **2015**, *17*, 2495–2503. doi:10.1039/c4gc02486a
94. Chen, T.; Cai, C. *Catal. Commun.* **2016**, *74*, 119–121. doi:10.1016/j.catcom.2015.11.011
95. Dabral, S.; Turberg, M.; Wanninger, A.; Bolm, C.; Hernández, J. G. *Molecules* **2017**, *22*, No. 146. doi:10.3390/molecules22010146
96. Kumar, K. S.; Kumar, P. M.; Kumar, K. A.; Sreenivasulu, M.; Jafar, A. A.; Rambabu, D.; Krishna, G. R.; Reddy, C. M.; Kapavarapu, R.; Shivakumar, K.; Priya, K. K.; Parsa, K. V. L.; Pal, M. *Chem. Commun.* **2011**, *47*, 5010–5012. doi:10.1039/c1cc10715a
97. Sashidhara, K. V.; Palnati, G. R.; Doddla, R. P.; Avula, S. R.; Swami, P. *Synlett* **2013**, *24*, 105–113. doi:10.1055/s-0032-1317761
98. Reddy, G. R.; Reddy, T. R.; Chary, R. G.; Joseph, S. C.; Mukherjee, S.; Pal, M. *Tetrahedron Lett.* **2013**, *54*, 6744–6746. doi:10.1016/j.tetlet.2013.09.138
99. Madhubabu, M. V.; Shankar, R.; Reddy, G. R.; Rao, T. S.; Rao, M. V. B.; Akula, R. *Tetrahedron Lett.* **2016**, *57*, 5033–5037. doi:10.1016/j.tetlet.2016.09.094
100. Guo, S.; Zhai, J.; Wang, F.; Fan, X. *Org. Biomol. Chem.* **2017**, *15*, 3674–3680. doi:10.1039/c7ob00256d
101. Zhang, J.; Zhang, F.; Lai, L.; Cheng, J.; Sun, J.; Wu, J. *Chem. Commun.* **2018**, *54*, 3891–3894. doi:10.1039/c8cc01124a
102. Kaicharla, T.; Thangaraj, M.; Biju, A. T. *Org. Lett.* **2014**, *16*, 1728–1731. doi:10.1021/ol500403x
103. Liu, L.; Bai, S.-H.; Li, Y.; Wang, L.-X.; Hu, Y.; Sung, H.-L.; Li, J. *J. Org. Chem.* **2017**, *82*, 11084–11090. doi:10.1021/acs.joc.7b02035
104. Liu, L.; Bai, S.-H.; Li, Y.; Ding, X.-D.; Liu, Q.; Li, J. *Adv. Synth. Catal.* **2018**, *360*, 1617–1621. doi:10.1002/adsc.201701580
105. Li, J.; Bai, S.; Li, Y.; Wang, Z.; Huo, X.; Liu, L. *J. Org. Chem.* **2018**, *83*, 8780–8785. doi:10.1021/acs.joc.8b01120
106. Shirri, M.; Ranjbar, M.; Yasaei, Z.; Zamanian, F.; Notash, B. *Org. Biomol. Chem.* **2017**, *15*, 10073–10081. doi:10.1039/c7ob02043k
107. Torres, G. M.; De La Higuera Macias, M.; Quesnel, J. S.; Williams, O. P.; Yempally, V.; Bengali, A. A.; Arndtsen, B. A. *J. Org. Chem.* **2016**, *81*, 12106–12115. doi:10.1021/acs.joc.6b02405
108. Grigg, R.; Gai, X.; Khamnaen, T.; Rajviroongit, S.; Sridharan, V.; Zhang, L.; Collard, S.; Keep, A. *Can. J. Chem.* **2005**, *83*, 990–1005. doi:10.1139/v05-111
109. Yin, H.; Skrydstrup, T. *J. Org. Chem.* **2017**, *82*, 6474–6481. doi:10.1021/acs.joc.7b00942
110. Zhou, K.; Xia, H.; Wu, J. *Org. Chem. Front.* **2016**, *3*, 865–869. doi:10.1039/c6qo00163g
111. Dondas, H. A.; Belveren, S.; Poyraz, S.; Grigg, R.; Kilner, C.; Ferrándiz-Saperas, M.; Selva, E.; Sansano, J. M. *Tetrahedron* **2018**, *74*, 6–11. doi:10.1016/j.tet.2017.11.017
112. Wang, H.; Sun, S.; Cheng, J. *Org. Lett.* **2017**, *19*, 5844–5847. doi:10.1021/acs.orglett.7b02827
113. Yu, Y.; Shin, K. J.; Seo, J. H. *J. Org. Chem.* **2017**, *82*, 1864–1871. doi:10.1021/acs.joc.6b02909
114. Park, S.; Lee, J.; Shin, K. J.; Oh, E.; Seo, J. H. *Molecules* **2017**, *22*, No. 503. doi:10.3390/molecules22030503
115. Park, S.; Shin, K. J.; Seo, J. H. *Synlett* **2015**, *26*, 2296–2300. doi:10.1055/s-0035-1560091
116. Boominathan, M.; Nagaraj, M.; Muthusubramanian, S.; Bhuvanesh, N. *RSC Adv.* **2014**, *4*, 18549–18557. doi:10.1039/c4ra02091j

## License and Terms

This is an Open Access article under the terms of the Creative Commons Attribution License (<http://creativecommons.org/licenses/by/4.0>). Please note that the reuse, redistribution and reproduction in particular requires that the authors and source are credited.

The license is subject to the *Beilstein Journal of Organic Chemistry* terms and conditions: (<https://www.beilstein-journals.org/bjoc>)

The definitive version of this article is the electronic one which can be found at: [doi:10.3762/bjoc.15.104](https://doi.org/10.3762/bjoc.15.104)



# Ugi reaction-derived prolyl peptide catalysts grafted on the renewable polymer polyfurfuryl alcohol for applications in heterogeneous enamine catalysis

Alexander F. de la Torre<sup>\*1</sup>, Gabriel S. Scatena<sup>2</sup>, Oscar Valdés<sup>3</sup>, Daniel G. Rivera<sup>\*4</sup> and Márcio W. Paixão<sup>\*2</sup>

## Full Research Paper

[Open Access](#)

### Address:

<sup>1</sup>Departamento de Química Orgánica, Facultad de Ciencias Químicas, Universidad de Concepción, Edmundo Larenas 234-interior-Casilla 160-C-Concepción, Chile, <sup>2</sup>Márcio W. Paixão, Departamento de Química, Universidade Federal de São Carlos, São Carlos, SP, 97105-900, Brazil, <sup>3</sup>Vicerrectoría de Investigación y Postgrado, Universidad Católica del Maule, Talca 3460000, Chile and <sup>4</sup>Center for Natural Products Research, Faculty of Chemistry, University of Havana, Zapata y G, 10400, La Habana, Cuba

### Email:

Alexander F. de la Torre<sup>\*</sup> - [afernandezd@udec.cl](mailto:afernandezd@udec.cl); Daniel G. Rivera<sup>\*</sup> - [dgr@fq.uh.cu](mailto:dgr@fq.uh.cu); Márcio W. Paixão<sup>\*</sup> - [marelloweber@gmail.com](mailto:marelloweber@gmail.com)

<sup>\*</sup> Corresponding author

### Keywords:

flow chemistry; heterogeneous catalysis; multicomponent reactions; organocatalysis; polyfurfuryl alcohol

*Beilstein J. Org. Chem.* **2019**, *15*, 1210–1216.  
doi:10.3762/bjoc.15.118

Received: 27 December 2018

Accepted: 29 April 2019

Published: 04 June 2019

This article is part of the thematic issue "Multicomponent reactions III" and is dedicated to Prof. Ricardo Martínez Sánchez.

Guest Editor: T. J. J. Müller

© 2019 de la Torre et al.; licensee Beilstein-Institut.

License and terms: see end of document.

## Abstract

The multicomponent synthesis of prolyl pseudo-peptide catalysts using the Ugi reaction with furfurylamines or isocyanides is described. The incorporation of such a polymerizable furan handle enabled the subsequent polymerization of the peptide catalyst with furfuryl alcohol, thus rendering polyfurfuryl alcohol-supported catalysts for applications in heterogeneous enamine catalysis. The utilization of the polymer-supported catalysts in both batch and continuous-flow organocatalytic procedures proved moderate catalytic efficacy and enantioselectivity, but excellent diastereoselectivity in the asymmetric Michael addition of *n*-butanal to  $\beta$ -nitrostyrene that was used as a model reaction. This work supports the potential of multicomponent reactions towards the assembly of catalysts and their simultaneous functionalization for immobilization.

## Introduction

The immobilization of secondary amine-based catalysts onto organic polymers and silica gel has emerged as an effective strategy that combines the power of heterogeneous and

organocatalysis [1-3]. Asymmetric catalysis using polymer-supported chiral organocatalysts usually provides a much greener prospect for the synthesis of enantiomerically enriched building

blocks [4-6]. Importantly, immobilized catalysts allow for both recyclability of the catalyst and the implementation of continuous-flow procedures, which usually encompass high reaction yields and reduction of waste – aspects recognized as compatible with the principles of green chemistry [1-5].

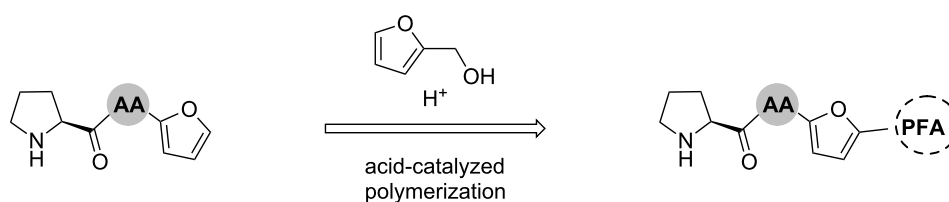
However, almost all polymers used in the development of supported organocatalysts are made from non-renewable sources and composed of non-biodegradable materials (e.g., polystyrene) [1-3]. When aiming at implementing large-scale catalytic processes with supported organocatalysts, a relevant “green” premise is the use of renewable and readily available solid supports [1-5]. Accordingly, we envisioned the utilization of the polymer polyfurfuryl alcohol (PFA) – derived from a renewable resource like sugar cane biomass – for the incorporation of chiral pyrrolidine-based motifs capable to catalyze relevant asymmetric reactions. The incorporation of an organocatalyst into a polymer support requires either conjugation to the polymer or functionalization with a polymerizable handle suitable for subsequent copolymerization with a monomeric counterpart. In this regard, multicomponent reactions (MCRs) provide a great opportunity for the simultaneous assembly of the catalyst along with the functionalization polymerizable handle. Orru and co-workers were the first to employ a three-component, diastereoselective variant of the Ugi reaction for the synthesis of a prolyl pseudo-peptide catalyst, which proved effective in an organocatalytic conjugate addition reaction [6].

Later, our groups developed an Ugi reaction-based multicomponent approach enabling the structure diversification of prolyl pseudo-peptide catalysts [7], which also proved great efficacy in organocatalytic asymmetric Michael reactions. As extension of this concept to the field of immobilized organocatalysts, we reported the use of the multicomponent approach for the synthesis of silica-grafted peptide catalysts for applications in continuous-flow catalysis [8]. In an endeavor to develop a cheaper and renewable polymer-supported organocatalyst, herein we describe the multicomponent synthesis of furfuryl-containing prolyl pseudo-peptide catalysts and their subsequent utilization in the preparation of PFA-supported catalysts amenable for continuous-flow asymmetric enamine catalysis [9,10].

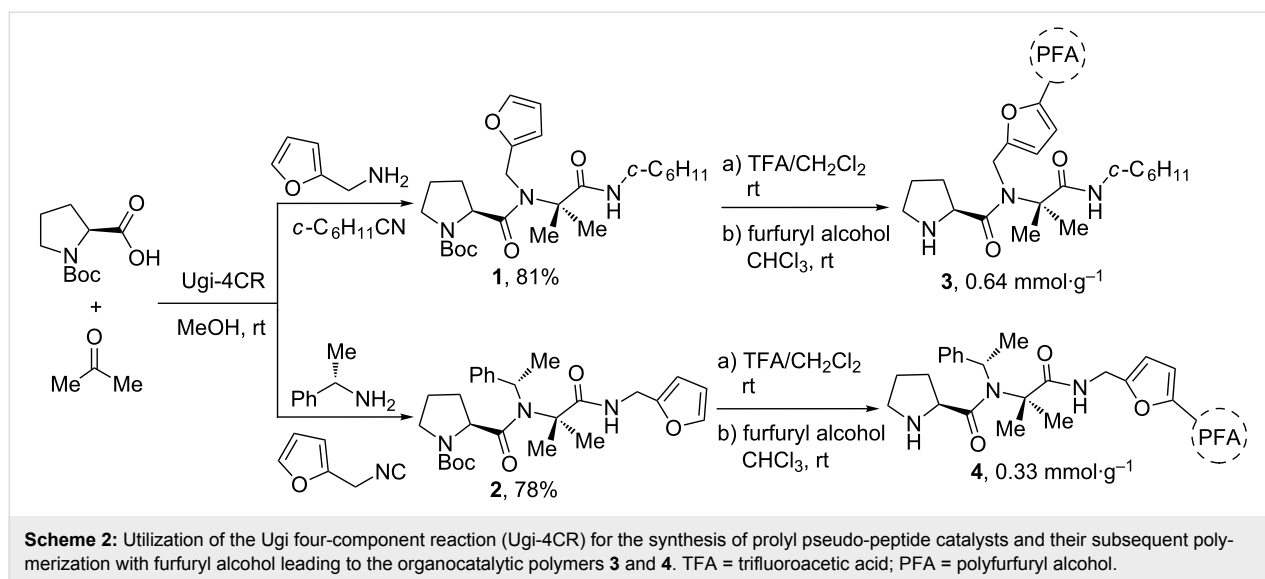
The acid-catalyzed polymerization of furfuryl alcohol renders a dark polymer featuring a complex cross-linked polyunsaturated scaffold derived from polycondensation and Diels–Alder reactions [11,12]. Worldwide, there is a well-established industry of furfural production from corncobs and sugarcane pentoses, making polymers derived from this material among the most versatile and promising due to their renewable character and easy exploitation of such biomasses [12,13]. As depicted in Scheme 1, we envisioned the synthesis of prolyl pseudo-peptides having a furan ring handle, which could be subsequently incorporated into PFA during the polymerization process.

## Results and Discussion

To this end, a solution-phase multicomponent procedure based on the Ugi four-component reaction (Ugi-4CR) [14], was employed to incorporate proline [15] and the furan functionality into pseudo-peptide catalysts. As shown in Scheme 2, Boc-L-proline and acetone were employed as acid and oxo components, respectively, in combination either with furfurylamine and cyclohexyl isocyanide or with (*S*)- $\alpha$ -methylbenzylamine and furfuryl isocyanide. We have previously proven the feasibility of this multicomponent approach for the combinatorial synthesis and rapid screening of pseudo-peptide catalysts [7] and their silica gel-immobilized variants [8]. The choice of using acetone and the *S*-configured  $\alpha$ -methylbenzylamine was made in agreement with our previous success with this class of peptide catalyst [7]. In this sense, the corresponding (*R*)- $\alpha$ -methylbenzylamine was not considered because of the good results achieved with the *S*-configured amine, albeit it remains unknown whether there is a match or mismatch between the configuration of the amine and the enantio- and diastereoselectivity of the catalytic process. In this case, furfuryl derivatives – used either as amine or isocyanide component – were ligated [16] to the peptide skeleton aimed at assessing whether the position of the polymerizable handle was important for the organocatalytic performance. Peptides **1** and **2** were subjected to Boc deprotection by treatment with 20% trifluoroacetic acid (TFA) in CHCl<sub>3</sub> followed by TFA-catalyzed polymerization in the presence of furfuryl alcohol (10 equiv) according to a literature procedure described for PFA [17] (Scheme 2). The polymeriza-



**Scheme 1:** Schematic synthesis of polyfurfuryl alcohol (PFA) incorporating a prolyl peptide catalyst. AA: Amino acid.



tion starts as a green solution that eventually turns brown and then black. The polymer suspension was neutralized by washing with a 1 M aqueous solution of NaOH and then precipitated from petroleum ether. The resulting dark solid was ground until the retained material on a 45  $\mu\text{m}$  sieve was less than 10%, thus rendering enough material of PFA-supported prolyl pseudo-peptide catalysts **3** and **4**.

The microanalyses of the polymeric catalysts **3** and **4** show a catalyst loading of 0.64 mmol·g<sup>-1</sup> and 0.33 mmol·g<sup>-1</sup>, respectively, calculated according to the content of nitrogen by CNHS analysis. The FTIR spectra of polymers **3** and **4** were compared with that of PFA, clearly showing the incorporation of the peptidic moiety into the PFA matrix (see Supporting Information File 1). In detail, the new bands appearing at around 3120 (N–H stretching), 1680 (C=O stretching), 1540 (N–H bending) and 1200 cm<sup>-1</sup> (CN stretching) are attributed to the typical amide vibrations and are not present in neat PFA. In addition, the bands at around 800, 740 and 600 cm<sup>-1</sup> confirm the presence of a 2,5-disubstituted furan ring typical of the PFA polymeric matrix [18].

The thermo-oxidative degradation of polymeric catalysts **3** and **4** was also examined using TGA, and compared with that of PFA (see Supporting Information File 1). This analysis showed that both polymers **3** and **4** are quite stable up to 100 °C, but as expected, decompose earlier than neat PFA. Thus, as main difference a significant loss of mass is observed for **3** and **4** at the range of 100–300 °C, whereas neat PFA is still stable at that temperature. This first degradation can be attributed to the decomposition of the peptidic skeleton, while at around 300 °C the decomposition of the polymeric lattice matrix starts, also of PFA. This analysis further demonstrates the incorporation of the

peptide moieties into the PFA matrix, while proving the good stability of the PFA-supported catalysts under classic working temperatures (i.e., up to 100 °C).

To assess the catalytic performance of the PFA-supported catalysts, the model system consisting in organocatalytic conjugate addition of *n*-butanal to *trans*- $\beta$ -nitrostyrene was implemented. During the initial screening, standard reaction conditions comprising the use of 10 mol % of catalyst, toluene as solvent and room temperature were chosen. As shown in Table 1, PFA – used as control – did not afford the Michael product (Table 1, entry 1) due to the lack of the catalytic pyrrolidine moiety. On the other hand, PFA-supported catalysts **3** and **4** gave moderate to good yields depending on the solvent used. In general, polymeric catalyst **3** provided a better yield, enantio- and diastereoselectivity in the Michael adduct than **4** in all tested solvents and conditions.

As PFA-supported catalyst **3** proved more effective than **4**, a comprehensive screening of solvents was carried out for the asymmetric Michael addition catalyzed by **3**. This study showed that the yield can be increased up to 90% using isopropanol (Table 1, entry 9), while the diastereoselectivity remains constantly high in all solvents [19]. Unfortunately, the enantioselectivity of the Michael additions remained moderate with both catalysts in all tested solvents and conditions, only rising to 84% ee when using catalyst **3** in toluene. The reason of the better catalytic performance of PFA-supported catalyst **3** compared to **4** may be not only due to higher catalyst loading in the polymer, but also because of the position of the furan ring. During the implementation of the heterogeneous organocatalytic reaction in batch, some polymer features proved limiting the efficiency. For example, the polymer powder showed to be

**Table 1:** Screening of PFA-supported prolyl pseudo-peptide catalysts and the reaction conditions in a batch heterogeneous Michael addition.

entry <sup>a</sup>	catalyst	solvent	yield of <b>5</b> (%) <sup>b</sup>	dr (syn/anti) <sup>c</sup>	ee (%) <sup>d</sup>
1	PFA	toluene	–	–	–
2	3	toluene	58	95:5	84
3	4	toluene	52	94:6	29
4	3	THF	83	93:7	77
5	4	THF	62	96:4	53
6	3	acetonitrile	72	94:6	54
7	3	<i>n</i> -hexane	54	95:5	56
8 <sup>e</sup>	3	<i>n</i> -hexane/ <i>i</i> PrOH	70	96:4	68
9	3	<i>i</i> PrOH	90	97:3	61
10	3	ethanol	69	96:4	53
11	3	H <sub>2</sub> O	76	96:4	66

<sup>a</sup>All reactions were conducted using 10 mol % of catalyst, 0.25 mmol of  $\beta$ -nitrostyrene and 3 equiv of *n*-butanal in 1 mL of solvent for 24 h. <sup>b</sup>Yield of isolated pure product. <sup>c</sup>Determined by <sup>1</sup>H NMR spectroscopy analysis of the crude product. <sup>d</sup>Determined by chiral-stationary phase HPLC analysis on the pure product. <sup>e</sup>9:1 mixture of *n*-hexane/*i*sopropanol.

of low density, thus making it difficult to recover the catalysts by decantation. In addition, gravity filtration was employed, however, the powder material mostly remained in the filter paper. To overcome this problem, we turned to implement a continuous-flow organocatalytic system by charging an HPLC column with PFA-supported catalyst **3**. Thus, polymer **3** was packed into a stainless-steel column ( $\varnothing = 0.21$  cm (diameter),  $l = 15$  cm (length), particle size = 45  $\mu$ m). The main features of the resulting packed microreactor were determined by pycnometry methodology [20,21], as reported in Table 2.

This method consists in filling the microreactor successively with two distinct solvents (here noted as 1, ethanol and 2, *n*-hexane) and then weighing the filled microreactor accurately. The difference between the masses ( $w$ ) of the filled reactor divided by the differences of solvent densities ( $\delta$ ) permits to calculate the microreactor void volume ( $V_0$ , dead volume). This feature is important because it provides an idea of the volume not utilized in the microreactor. The catalyst's loading was kept

as determined by microanalysis, as previously described for polymeric catalyst **3**. The packing amount ( $w_{\text{tot}}$ ) was also determined by pycnometry. Porosity ( $\epsilon_{\text{tot}}$ ) of 0.67 is an optimal value for this material, which is according to the accepted values. One of the most important features of a microreactor for continuous-flow chemistry is the residence time ( $\tau$ ) which is known as the time in which a substrate passes through the microreactor without interacting. In some cases, this residence time is measured by the time a dye needs to pass through the reactor. In this work, it was calculated by dividing  $V_0$  by the used flow rate ( $\Phi$ ) of 2.5  $\mu$ L/min.

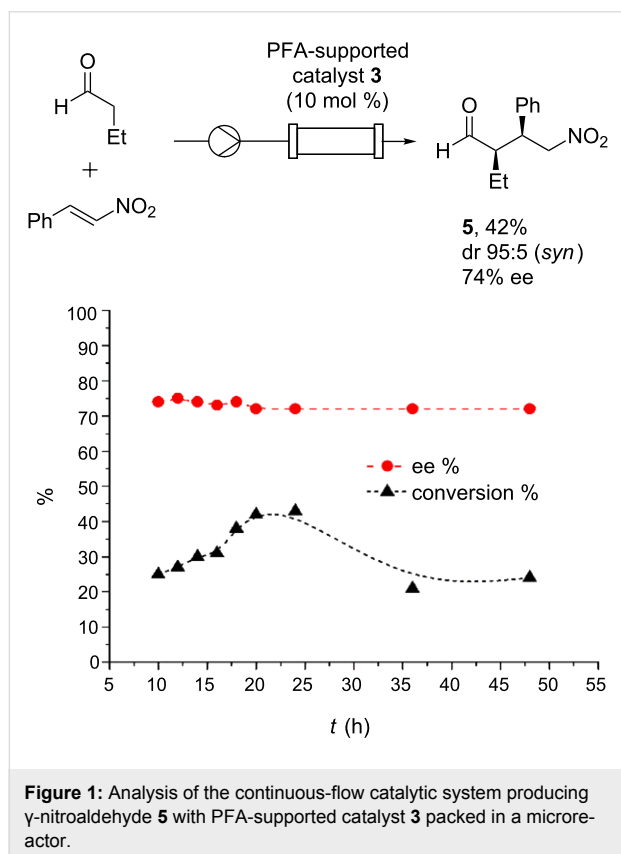
The study of the Michael reaction under continuous-flow conditions started with the optimization of the flow rate. Initially, a solution of  $\beta$ -nitrostyrene (1 equiv, 0.25 M) and *n*-butanal (3 equiv, 0.75 M) in toluene was pumped using a syringe-pump at 2.5  $\mu$ L·min<sup>-1</sup> ( $\tau = 140$  min, Figure 1, top). The concentration was chosen by considering the retention profile of *n*-butanal and  $\beta$ -nitrostyrene in the microreactor. After 22 h, a moderate

**Table 2:** Main features of the catalytic microreactor.

loading of <b>3</b> (mmol·g <sup>-1</sup> ) <sup>a</sup>	amount $w_{\text{tot}}$ (mg) <sup>b</sup>	$V_0$ ( $\mu$ L) <sup>c</sup>	$V_G$ ( $\mu$ L) <sup>d</sup>	$V_{\text{bed}}$ ( $\mu$ L) <sup>e</sup>	$\tau$ (min) <sup>f</sup>	$\epsilon_{\text{tot}}$ <sup>g</sup>
0.639	264	349	519	170	140	0.67

<sup>a</sup>Determined by elemental analysis. <sup>b</sup> $w_{\text{tot}} = V_0 \delta_0 + w_{\text{ads}} + w_{\text{hw}}$ . <sup>c</sup> $V_0 = w_1 - w_2 / \delta_1 - \delta_2$ . <sup>d</sup>Geometric volume  $V_G = \pi \cdot h \cdot r^2 \cdot 10^3$  ( $h = 15$  cm,  $r = 0.105$  cm). <sup>e</sup> $V_{\text{bed}} = V_G - V_0$ . <sup>f</sup>Residence time calculated at flow rate  $\Phi = 2.5$   $\mu$ L·min<sup>-1</sup>,  $\tau = V_0 / \Phi$ . <sup>g</sup>Total porosity  $\epsilon_{\text{tot}} = V_0 / V_G$ .

conversion of the  $\beta$ -nitrostyrene in toluene was observed, proving a poor efficiency of the process and a low value of productivity. This clearly showed that the conversion of the starting material is increasing until 24 h, and after that, the reactor productivity decreases considerably (Figure 1, bottom). We hypothesized that the higher residence time of  $\beta$ -nitrostyrene in the reactor may lead to a lower yield or the catalyst may acquire inactivation. Accordingly, all the substrates were injected into the reactor coupled to a HPLC system and the retention times of each substrate within the reactor were measured by UV detection at a wavelength of 210 nm. A retention time of 70 min for  $\beta$ -nitrostyrene at a flow rate of 0.1 mL/min into the reactor was observed. Then, this preferential occupancy of the packing material by  $\beta$ -nitrostyrene (50 times as residence time calculated) limits the formation of the Michael product and, consequently, lowers the chemical efficiency. Despite the good level of diastereocontrol in Michael addition (dr 95:5 *syn/anti*), a little drop in the enantioselectivity was observed (i.e., 74% ee) compared to the batch process with the same catalyst. Nonetheless, the enantioselectivity remains constant during the whole time of experiment, as shown in Figure 1. Finally, the overall yield of isolated Michael adduct **5** was 42% after column chromatography, which is in agreement with the conversion determined during the continuous-flow study.



**Figure 1:** Analysis of the continuous-flow catalytic system producing  $\gamma$ -nitroaldehyde **5** with PFA-supported catalyst **3** packed in a microreactor.

## Conclusion

In conclusion, we have implemented a multicomponent approach for the one-pot assembly of furfuryl-containing organocatalysts suitable for the incorporation into a polyfurfuryl polymer. Two polymer-supported prolyl peptide catalysts were produced by means of an initial Ugi reaction followed by an acid-catalyzed polymerization. They catalytic polymers were screened in the heterogeneous catalytic Michael addition in batch, proving that catalyst **3** is more effective and provides better stereoselectivity. A continuous-flow organocatalytic system was also implemented using catalyst **3**, enabling the continuous production of a  $\gamma$ -nitroaldehyde in moderate yield and enantioselectivity, but with excellent diastereoselectivity.

## Experimental

$^1\text{H}$  NMR and  $^{13}\text{C}$  NMR spectra were recorded at 400 MHz for  $^1\text{H}$  and 100 MHz for  $^{13}\text{C}$ , respectively. Chemical shifts ( $\delta$ ) are reported in parts per million relative to the residual solvent signals, and coupling constants ( $J$ ) are reported in hertz. Flash column chromatography was carried out using silica gel 60 (230–400 mesh) and analytical thin-layer chromatography (TLC) was performed using silica gel aluminum sheets. HPLC chromatograms were obtained on a Shimadzu apparatus, LC-10AT Pump, SPD-10A UV-vis detector, SCL-10A system controller, using a Chiralpak AD-H (4.6 mm  $\varnothing$   $\times$  250 mm length, particle size 5  $\mu\text{m}$ ). Optical rotations were measured at the indicated temperature using a Perkin-Elmer Polarimeter, Mod. 241, (wavelength: 589 nm). Melting points were obtained in a MQAPF-301 apparatus.

**General procedure A.** A suspension of the amine (1.0 mmol) and acetone (1.0 mmol) in MeOH (5 mL) was stirred for 1 h at room temperature. The carboxylic acid (1.0 mmol) and the isocyanide (1.0 mmol) were then added and the reaction mixture was stirred at room temperature for 24 h. The volatiles were removed under reduced pressure and the resulting crude product was dissolved in 100 mL of  $\text{CH}_2\text{Cl}_2$ . The organic phase was washed sequentially with an aqueous saturated solution of citric acid (50 mL), aqueous 10%  $\text{NaHCO}_3$  (50 mL), and brine (50 mL), and then dried over anhydrous  $\text{Na}_2\text{SO}_4$  and concentrated under reduced pressure.

**General procedure B.** The prolyl pseudo-peptides catalyst was dissolved in 3 mL of  $\text{CH}_2\text{Cl}_2$  and treated with 1 mL of trifluoroacetic acid at 0  $^\circ\text{C}$ . The reaction mixture was allowed to reach room temperature, stirred for 4 h and then concentrated to dryness (the excess of TFA was removed by repetitive addition and evaporation of further  $\text{CH}_2\text{Cl}_2$ ). The crude product was re-dissolved in 10 mL of  $\text{CHCl}_3$  for the polymerization step. To a suspension of the salt pseudo-peptide catalysts (1.0 mmol, 1 equiv) and furfuryl alcohol (10 mmol, 10 equiv) in  $\text{CHCl}_3$

(5 mL) was added TFA (0.5 mmol, 5 mol %) dropwise over 10 min, and stirred for 24 h at room temperature. The color of the solution changed during the reaction from yellow-green to brown then black. The neutralization of the polymerization solution was carried out with a concentrated basic solution. The use of a 1 M NaOH (5 mL) solution requires two washes of 10 min each but at the end of the reaction an emulsion may appear. In order to avoid this problem an excess of 0.1 M NaOH solution was used. Polymers were isolated by precipitation in petroleum ether and dried in high vacuum. The resulting dark solid was ground until the retained material on a 45  $\mu\text{m}$  sieve was lower than 10%.

**PFA:** For comparison, PFA was prepared in a conventional way according to a reported procedure [17].

**General procedure C.** The nitroolefin (0.25 mmol, 1.0 equiv) and the aldehyde (0.75 mmol, 3.0 equiv) were added to a solution of the prolyl pseudo-peptide catalyst (0.025 mmol, 0.01 equiv) in the solvent of choice (1 mL). The reaction mixture was stirred for 24 h and then concentrated under reduced pressure. The resulting crude product was purified by flash column chromatography on silica gel using *n*-hexane/EtOAc as eluent. Enantiomeric excess (ee) was determined by chiral HPLC analysis through comparison with the authentic racemic material. Assignment of the stereoisomers was performed by comparison with literature data.

## Synthesis and characterization

**Prolyl pseudo-peptide 1.** Furfurylamine (177  $\mu\text{L}$ , 2 mmol), acetone (116 mg, 2 mmol), Boc-L-Pro-OH (431 mg, 2 mmol) and cyclohexyl isocyanide (249  $\mu\text{L}$ , 2 mmol) were reacted in MeOH (5 mL) according to the general procedure A. Flash column chromatography purification (EtOAc/hexane 1:1, v/v) afforded the Boc-proline-based peptide **1** as colorless oil. A mixture of conformers was observed by NMR (ratio 3:1). Assigned signals belong to the mixture of conformers. Yield: 81%;  $R_f$  0.34 (EtOAc/hexane 1:1, v/v);  $[\alpha]_D^{20} - 19.9$  ( $c$  0.0085  $\text{g}\cdot\text{cm}^{-3}$ , MeOH);  $^1\text{H}$  NMR (400 MHz,  $\text{CDCl}_3$ )  $\delta$  0.99–1.19 (m, 3H), 1.29–1.39 (m, 2H), 1.43 (s, 3H), 1.45 (s, 9H), 1.48 (s, 3H), 1.58–2.01 (m, 9H), 2.10 (m, 1H), 3.39 (m, 1H), 3.53 (m, 1H), 3.65 (m, 1H); 4.50, 4.52 (2 $\times$ d,  $J$  = 16.0 Hz, 1H), 4.60 (m, 1H), 4.77, 5.09 (2 $\times$ d,  $J$  = 18.2 Hz, 1H), 5.70, 5.94 (2 $\times$ d,  $J$  = 7.2 Hz, NH, 1H), 6.39 (m, 1H), 7.40 (d,  $J$  = 7.8 Hz, 1H);  $^{13}\text{C}$  NMR (100 MHz,  $\text{CDCl}_3$ )  $\delta$  23.1, 24.2, 24.4, 24.9, 25.1, 25.5, 28.6, 30.2, 32.7, 32.8, 41.5, 47.2, 48.4, 56.9, 63.3, 79.5, 107.3, 110.8, 141.9, 152.2, 154.7, 173.7, 174.1.

**Prolyl pseudo-peptide 2.** (*S*)-(-)- $\alpha$ -Methylbenzylamine (257  $\mu\text{L}$ , 2 mmol), acetone (147  $\mu\text{L}$ , 2 mmol), Boc-L-Pro-OH (431 mg, 2 mmol) and furfuryl isocyanide (216  $\mu\text{L}$ , 2 mmol)

were reacted in MeOH (5 mL) according to the general procedure A. Flash column chromatography purification (EtOAc/hexane 1:1, v/v) afforded the proline-based peptide **2** as colorless oil. Yield: 78%;  $R_f$  0.30 (EtOAc/hexane 1:1, v/v);  $[\alpha]_D^{23} - 6.26$  ( $c$  0.0047  $\text{g}\cdot\text{cm}^{-3}$ , MeOH);  $^1\text{H}$  NMR (400 MHz,  $\text{CDCl}_3$ )  $\delta$  1.40 (s, 9H), 1.41–1.75 (m, 9H), 1.94 (m, 3H), 3.26–3.37 (m, 2H), 4.08–4.11 (m, 2H), 4.59–4.65 (m, 1H), 6.23–6.29 (m, 2H), 7.26–7.40 (m, 4H), 7.53 (m, 2H);  $^{13}\text{C}$  NMR (100 MHz,  $\text{CDCl}_3$ )  $\delta$  19.2, 24.2, 24.4, 26.7, 28.9, 37.2, 47.7, 51.9, 59.3, 64.8, 79.5, 106.4, 110.4, 127.4, 128.9, 141.3, 142.8, 152.9, 154.8, 175.4, 175.5.

**PFA-supported catalyst 3.** Compound **1** (476 mg, 1 mmol, 1.0 equiv), furfuryl alcohol (860  $\mu\text{L}$ , 10 mmol, 10 equiv) and TFA (38  $\mu\text{L}$ , 0.5 mmol) were reacted in  $\text{CHCl}_3$  (5 mL) according to the general procedure B. After precipitation in petroleum ether, polymer **3** was obtained as a black amorphous solid. IR (KBr,  $\text{cm}^{-1}$ ): 3500, 3120, 2930, 2860, 1720, 1680, 1540, 1420, 1320, 1180, 1080, 790. 740, 600; microanalysis: N (2.68%), C (58.29%), H (5.12%), S (0%); loading = 0.64  $\text{mmol}\cdot\text{g}^{-1}$ .

**PFA-supported catalyst 4.** Compound **2** (545 mg, 1 mmol, 1.0 equiv), furfuryl alcohol (860  $\mu\text{L}$ , 10 mmol, 10 equiv) and TFA (38  $\mu\text{L}$ , 0.5 mmol) were reacted in  $\text{CHCl}_3$  (5 mL) according to the general procedure B. After precipitation in petroleum ether, polymer **4** was obtained as a black amorphous solid. IR (KBr,  $\text{cm}^{-1}$ ): 3500, 3120, 2930, 1720, 1680, 1610, 1550, 1420, 1350, 1200, 1160, 1110, 1038, 780, 740, 600; microanalysis: N (1.36%), C (50.52%), H (3.77%), S (0%); loading = 0.33  $\text{mmol}\cdot\text{g}^{-1}$ .

**PFA.** Furfuryl alcohol (860  $\mu\text{L}$ , 10 mmol) and TFA (38  $\mu\text{L}$ , 0.5 mmol) were reacted in  $\text{CHCl}_3$  (5 mL) according to the general procedure B. After precipitation in petroleum ether, PFA was afforded as a black amorphous solid. IR (KBr,  $\text{cm}^{-1}$ ): 3480, 2930, 1718, 1420, 1150, 1100, 800, 690, 600; microanalysis: N (0%), C (56.14%), H (4.10%), S (0%); loading of catalyst = 0  $\text{mmol}\cdot\text{g}^{-1}$ .

(2*R*,3*S*)-2-Ethyl-4-nitro-3-phenylbutanal (**5**). Prepared by reaction of *n*-butanal with *trans*- $\beta$ -nitrostyrene according to the general procedure C. The compound was purified by flash column chromatography (EtOAc/hexane 1:9, v/v). The spectroscopic data are in agreement with the published data [15]. The enantiomeric excess was determined by chiral-stationary phase HPLC (Chiralpak OD-H, hexane/*i*PrOH 99:1, v/v, 25  $^\circ\text{C}$ ) at 1.00 mL/min, UV detection at 210 nm:  $t_R$ : (*syn*, major) = 28.4 min, (*anti*, minor) = 20.9 min;  $R_f$  0.26 (EtOAc/hexane 2:8, v/v);  $[\alpha]_D^{23} + 25.21$  ( $c$  0.0046  $\text{g}\cdot\text{cm}^{-3}$ , MeOH);  $^1\text{H}$  NMR (400 MHz,  $\text{CDCl}_3$ )  $\delta$  9.72, 9.49 (2 $\times$ d,  $J$  = 2.6 Hz, 1H, CHO), 7.36–7.29 (m, 3H, Ph), 7.19–7.17 (m, 2H, Ph), 4.72 (dd,  $J$

5.0 Hz, 12.7 Hz, 1H, CH<sub>2</sub>NO<sub>2</sub>), 4.63 (dd, *J* = 9.6 Hz, 12.7 Hz, 1H, CH<sub>2</sub>NO<sub>2</sub>), 3.79 (td, *J* = 5.0 Hz, 9.8 Hz, 1H, CHPh), 2.71–2.65 (m, 1H, CHCHO), 1.54–1.47 (m, 2H, CH<sub>2</sub>CH<sub>3</sub>), 0.83 (t, *J* = 0.83 Hz, 3H, CH<sub>3</sub>); <sup>13</sup>C NMR (100 MHz, CDCl<sub>3</sub>) δ 203.2, 136.8, 129.1, 128.1, 128.0, 78.5, 55.0, 42.7, 20.4, 10.7.

**Preparation of microreactor column.** PFA-supported catalyst **3** (500 mg, excess, suspended in 25 mL of ethanol) was packed into a stainless-steel HPLC column (Ø = 2.1 mm, l = 150 mm, particle size ≤ 45 µm). The packing was performed under constant pressure (2500 psi) using ethanol (250 mL) as the solvent by using an air-driven liquid pump.

## Supporting Information

### Supporting Information File 1

<sup>1</sup>H and <sup>13</sup>C NMR spectra of prolyl pseudo-peptide catalysts and chiral-phase HPLC analysis of Michael adducts.

[<https://www.beilstein-journals.org/bjoc/content/supplementary/1860-5397-15-118-S1.pdf>]

## Acknowledgements

This work was supported by CNPq (INCT-Catálise), CAPES (CAPES-MES/Cuba Program) under Grant [number 14/50249-8]; FAPESP under Grant [number 15/17141-13170003]. A.F. de la Torre thanks to FONDECYT under Grant [number 3170003] for financial support. D. G. Rivera thanks FAPESP for a Visiting Professor Grant and O. Valdés thanks to FONDECYT 11170008.

## ORCID® IDs

Alexander F. de la Torre - <https://orcid.org/0000-0003-4767-5868>

Oscar Valdés - <https://orcid.org/0000-0003-1477-2549>

Daniel G. Rivera - <https://orcid.org/0000-0002-5538-1555>

## References

- Puglisi, A.; Benaglia, M.; Chiroli, V. *Green Chem.* **2013**, *15*, 1790–1813. doi:10.1039/c3gc40195b
- Tsubogo, T.; Ishiwata, T.; Kobayashi, S. *Angew. Chem., Int. Ed.* **2013**, *52*, 6590–6604. doi:10.1002/anie.201210066
- Kristensen, T. E.; Hansen, T. *Eur. J. Org. Chem.* **2010**, 3179–3204. doi:10.1002/ejoc.201000319
- Mak, X. Y.; Laurino, P.; Seeberger, P. H. *Beilstein J. Org. Chem.* **2009**, *5*, No. 19. doi:10.3762/bjoc.5.19
- Frost, C. G.; Mutton, L. *Green Chem.* **2010**, *12*, 1687–1703. doi:10.1039/c0gc00133c
- Znabet, A.; Ruijter, E.; de Kanter, F. J. J.; Köhler, V.; Helliwell, M.; Turner, N. J.; Orru, R. V. A. *Angew. Chem., Int. Ed.* **2010**, *49*, 5289–5292. doi:10.1002/anie.201001592
- de la Torre, A. F.; Rivera, D. G.; Ferreira, M. A. B.; Corrêa, A. G.; Paixão, M. W. *J. Org. Chem.* **2013**, *78*, 10221–10232. doi:10.1021/jo401609z
- Scatena, G. S.; de la Torre, A. F.; Cass, Q. B.; Rivera, D. G.; Paixão, M. W. *ChemCatChem* **2014**, *6*, 3208–3214. doi:10.1002/cctc.201402501
- Arakawa, Y.; Wiesner, M.; Wennemers, H. *Adv. Synth. Catal.* **2011**, *353*, 1201–1206. doi:10.1002/adsc.201100118
- Arakawa, Y.; Wennemers, H. *ChemSusChem* **2013**, *6*, 242–245. doi:10.1002/cssc.201200740
- Kim, T.; Assary, R. S.; Marshall, C. L.; Gosztola, D. J.; Curtiss, L. A.; Stair, P. C. *ChemCatChem* **2011**, *3*, 1451–1458. doi:10.1002/cctc.201100098
- Gandini, A. *Polym. Chem.* **2010**, *1*, 245–251. doi:10.1039/b9py00233b
- Gandini, A. *Macromolecules* **2008**, *41*, 9491–9504. doi:10.1021/ma801735u
- Ugi, I.; Meyr, R.; Fetzer, U.; Steinbrücker, C. *Angew. Chem.* **1959**, *71*, 386.
- Rivera, D. G.; León, F.; Concepción, O.; Morales, F. E.; Wessjohann, L. A. *Chem. – Eur. J.* **2013**, *19*, 6417–6428. doi:10.1002/chem.201201591
- Reguera, L.; Méndez, Y.; Humpierre, A. R.; Valdés, O.; Rivera, D. G. *Acc. Chem. Res.* **2018**, *51*, 1475–1486. doi:10.1021/acs.accounts.8b00126
- Principe, M.; Martínez, R.; Ortiz, P.; Rieumont, J. *Polim.: Cienc. Tecnol.* **2000**, *10*, 8–14. doi:10.1590/s0104-14282000000100004
- Choura, M.; Belgacem, N. M.; Gandini, A. *Macromolecules* **1996**, *29*, 3839–3850. doi:10.1021/ma951522f
- Fernández de la Torre, A. Multicomponent Reactions in the Discovery of Organocatalysts and the Diversification of Organocatalytic Approaches. Ph.D. Thesis, Universidade Federal de São Carlos, Brazil, 2015.
- Bortolini, O.; Cavazzini, A.; Giovannini, P. P.; Greco, R.; Marchetti, N.; Massi, A.; Pasti, L. *Chem. – Eur. J.* **2013**, *19*, 7802–7808. doi:10.1002/chem.201300181
- McCormick, R. M.; Karger, B. L. *Anal. Chem. (Washington, DC, U. S.)* **1980**, *52*, 2249–2257. doi:10.1021/ac50064a005

## License and Terms

This is an Open Access article under the terms of the Creative Commons Attribution License (<http://creativecommons.org/licenses/by/4.0>). Please note that the reuse, redistribution and reproduction in particular requires that the authors and source are credited.

The license is subject to the *Beilstein Journal of Organic Chemistry* terms and conditions: (<https://www.beilstein-journals.org/bjoc>)

The definitive version of this article is the electronic one which can be found at: [doi:10.3762/bjoc.15.118](https://doi.org/10.3762/bjoc.15.118)



# Steroid diversification by multicomponent reactions

Leslie Reguera<sup>‡1</sup>, Cecilia I. Attorresi<sup>‡2,3</sup>, Javier A. Ramírez<sup>\*2,3</sup> and Daniel G. Rivera<sup>\*1</sup>

## Review

Open Access

### Address:

<sup>1</sup>Center for Natural Product Research, Faculty of Chemistry, University of Havana, Zapata y G, Havana 10400, Cuba,

<sup>2</sup>Departamento de Química Orgánica, Facultad de Ciencias Exactas y Naturales, Universidad de Buenos Aires. Ciudad Universitaria, Ciudad Autónoma de Buenos Aires, C1428EGA, Argentina and <sup>3</sup>CONICET – Universidad de Buenos Aires. Unidad de Microanálisis y Métodos Físicos Aplicados a Química Orgánica (UMYMFOR). Ciudad Universitaria, Ciudad Autónoma de Buenos Aires, C1428EGA, Argentina

### Email:

Javier A. Ramírez<sup>\*</sup> - jar@qo.fcen.uba.ar; Daniel G. Rivera<sup>\*</sup> - dgr@fq.uh.cu

\* Corresponding author ‡ Equal contributors

### Keywords:

conjugation; heterocycles; macrocycles; multicomponent reactions; steroids

*Beilstein J. Org. Chem.* **2019**, *15*, 1236–1256.

doi:10.3762/bjoc.15.121

Received: 30 January 2019

Accepted: 14 May 2019

Published: 06 June 2019

This article is part of the thematic issue "Multicomponent reactions III".

Guest Editor: T. J. J. Müller

© 2019 Reguera et al.; licensee Beilstein-Institut.

License and terms: see end of document.

## Abstract

Reports on structural diversification of steroids by means of multicomponent reactions (MCRs) have significantly increased over the last decade. This review covers the most relevant strategies dealing with the use of steroidal substrates in MCRs, including the synthesis of steroidal heterocycles and macrocycles as well as the conjugation of steroids to amino acids, peptides and carbohydrates. We demonstrate that steroids are available with almost all types of MCR reactive functionalities, e.g., carbonyl, carboxylic acid, alkyne, amine, isocyanide, boronic acid, etc., and that steroids are suitable starting materials for relevant MCRs such as those based on imine and isocyanide. The focus is mainly posed on proving the amenability of MCRs for the diversity-oriented derivatization of naturally occurring steroids and the construction of complex steroid-based platforms for drug discovery, chemical biology and supramolecular chemistry applications.

## Review

### 1 Introduction

The utilization of multicomponent reactions (MCRs) [1] for the derivatization of biomolecules has continuously grown over the last years. These diversity-oriented and complexity-generating processes [2,3] have proven success in peptide ligation [4] and macrocyclization [5,6], protein glycoconjugation [7], lipidation

of peptides [8] and glycosides [9], and carbohydrate modification [10]. A special class of lipidic biomolecules are the steroids, which can be either totally lipophilic (e.g., cholesterol) or amphipathic when possessing both polar and nonpolar groups (e.g., cholic acid). As shown in Figure 1, members of this

family can be found in both plant and animal kingdoms, where they exert an amazing array of cellular functions such as structural and hormonal ones. All steroids are based on a common skeleton containing three fused six-membered rings and one five membered ring. This fused-ring system provides a readily available source of rigidity and chirality, whose substituents can be oriented either towards the  $\alpha$ - or the  $\beta$ -face. Steroids feature a polyprenyl nature, which is particularly evident in the side chain, and have additional structural elements such as the methyl groups at positions 10 and 13, always  $\beta$ -oriented. Other positions of the steroidal nucleus of frequent natural functionalization are C-3 (usually bearing a hydroxy group) and C-17, this latter holding the aliphatic side chain but also often having oxygenated functions [11]. Similarly, rings B and C can be naturally functionalized with a varied set of groups including hydroxy, carbonyl and olefins, which along with those present in rings A and D and the side chain are the basis of steroid biological functions. Such oxygenated and alkene groups represent the entrance door for subsequent synthetic modifications, including the incorporation of MCR reactive functionalities.

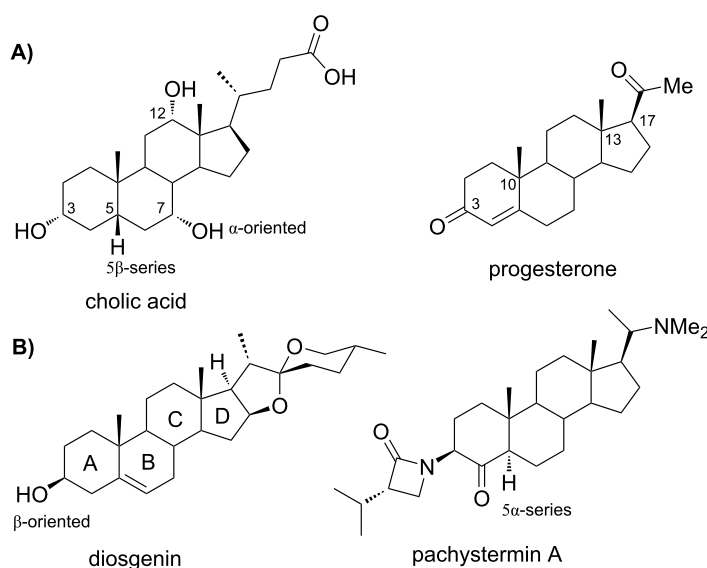
In the last two decades, MCRs have emerged as effective tools for the rapid derivatization of steroidal skeletons in the pursuit of medicinal and supramolecular chemistry applications. Despite some review articles have described selected examples of MCRs used to modify and to macrocyclize steroidal compounds [12,13], to our knowledge there is no review exclusively dedicated to covering the applications of MCRs with steroids. Herein, we provide a comprehensive review describing – to our understanding – the most important inputs of the utilization of

MCRs in the structural diversification of steroids. The review is divided in different aspects of steroid chemistry, such as modification of the side chain and the steroidal nucleus, the assembly of nitrogen-heterocycles fused to the steroid-ring system, the steroid conjugation and macrocyclization, all relying on MCRs.

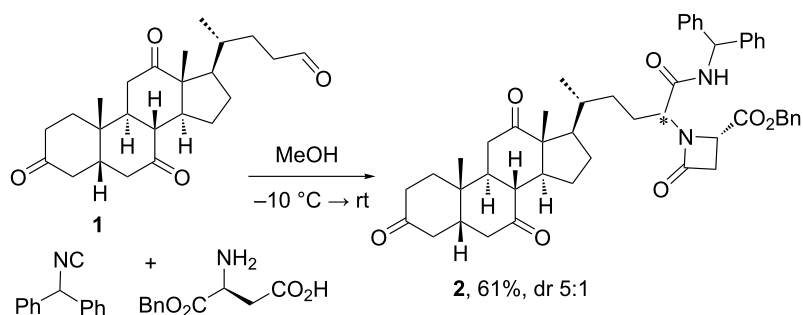
## 2 Modification of the steroidal nucleus and the side chain

### 2.1 Isocyanide-based MCRs

**2.1.1 Steroids as carbonyl component:** One of the first steroid derivatization methods using MCRs was reported by the Ugi laboratory in 1995 (Scheme 1) [14]. The occurrence of pachystermin A, an unusual natural steroid isolated from the boxaceous plant *Pachysandra terminalis* and having a  $\beta$ -lactam moiety in ring A, inspired these authors to obtain a steroidal  $\beta$ -lactam, albeit functionalized in the side chain. The one-pot synthesis of the  $\beta$ -lactam steroid was achieved via the Ugi 3-component-4-center reaction using the dehydrocholic aldehyde **1** as carbonyl component. This variation of the Ugi reaction including a  $\beta$ -amino acid component allows the formation of the 4-membered ring of the  $\beta$ -lactam moiety, which is difficult to obtain through other traditional methods like the cyclization of acyclic precursors because of both the Baeyer strain of the newly formed ring and conformational effects [15]. However, the readily formation of the 4-membered ring by this MCR is due to the ring contraction of the 7-membered ring cyclic intermediate by transannular acyl transfer, which leads to the  $\beta$ -lactam derivative. Despite the chiral nature of the steroidal substrate, no significant stereoselective induction was observed, probably because the 7-membered ring intermediate was far away from the chiral steroidal nucleus.



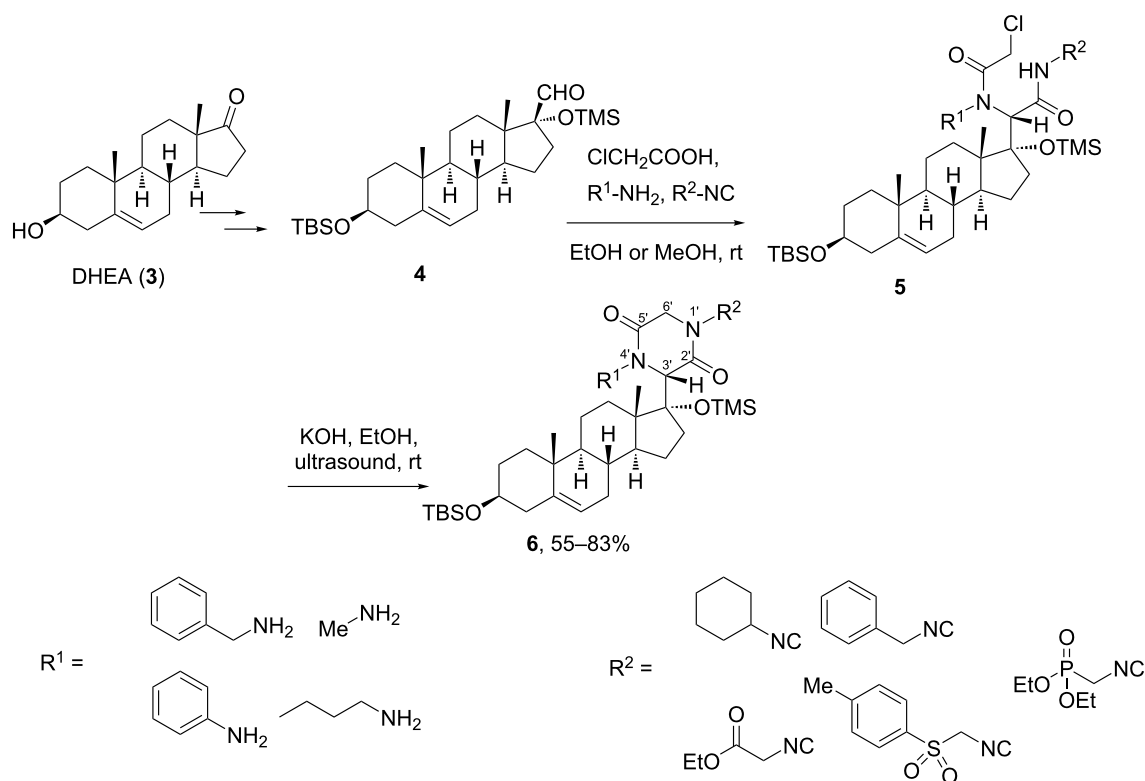
**Figure 1:** Structures of natural steroids of A) animal and B) plant origin.



**Scheme 1:** Synthesis of a steroidal  $\beta$ -lactam by Ugi reaction of a cholanic aldehyde [14].

A better stereoselectivity was reported by Bruttomesso et al. in their work on the Ugi four-component reaction (Ugi-4CR) with a steroidal aldehyde, in which the carbonyl group was directly linked at the steroidal framework [16]. As shown in Scheme 2, the authors found a high diastereoselectivity in the Ugi-4CR conducted with a carbonyl linked at C-17, a sterically crowded position very close to the axial methyl group placed of C-13. This step was implemented as part of the synthetic route toward steroidal 2,5-diketopiperazine **6**, based on a strategy previously proposed by Marcaccini and co-workers [17]. Here, the route

included the Ugi-4CR reaction of varied amines and isocyanides with the androstanic aldehyde **4** and chloroacetic acid followed by a post-cyclization reaction by treating the Ugi products **5** with ethanolic KOH under ultrasonication. This protocol provided a small library of steroidal 2,5-diketopiperazines **6** obtained as a single diastereomer, thus proving the high diastereoselection of the initial Ugi-4CR with the steroidal carbonyl substrate. In the 2,5-diketopiperazine ring, the configuration of the new asymmetric center C-3' was *S*, a result confirmed by NOESY experiments.



**Scheme 2:** Synthetic route to steroidal 2,5-diketopiperazines based on a diastereoselective Ugi-4CR with an androstanic aldehyde derived from dehydroepiandrosterone (DHEA) [16].

In comparison with the work described above, it can be suggested that in the case of the 2,5-diketopiperazine synthesis, the distance of the carbonyl moiety to the steroidal nucleus is determinant for the diastereoselection of the Ugi-type reaction. Thus, when the carbonyl is far away from the rigid chiral steroid, the Ugi reaction shows no significant diastereoselectivity, while the carbonyl component directly linked to the bulky steroidal nucleus – especially in  $\alpha$ -position of a stereocenter – provides a very good diastereocontrol in the MCR.

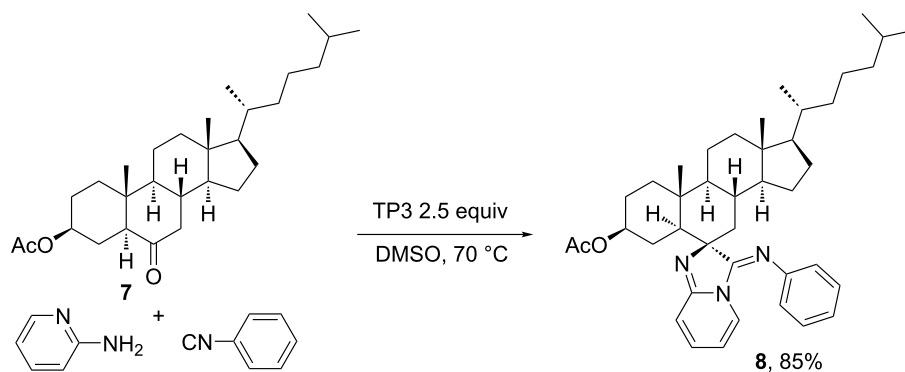
Dar et al. [18] reported another example of a diastereoselective MCR between a 6-ketosteroid, 2-aminopyridines and an isocyanide, using propylphosphonic acid anhydride (TP3) as catalyst to afford a steroidal derivative with an imidazole-pyridine moiety attached to ring B. This moiety is present in several compounds displaying biological activities such as antimicrobial, antiviral and anti-inflammatory, among others. Scheme 3 exemplifies the reaction of cholestan-6-one **7** with 2-aminopyridine and phenyl isocyanide to afford the heterocycle-steroid hybrid **8** in good yield and diastereoselectivity, whereas different ketosteroids could be used as starting materials, thus proving the versatility of this reaction. Also, this group extended the reaction scope to different 2-aminopyridines with electron-donating groups in *para* and *meta* positions, and to benzyl and other alkyl isocyanides. The proposed mechanism follows the first step of the Ugi-4CR reaction, i.e., the formation of the imine between the ketosteroid and the amine group of the aminopyridine derivative. Then, the imine suffers the nucleophilic attack of the isocyanide generating a nitrilium intermediate. Differently from the Ugi-4CR, the final step is the cyclization between the pyridine N atom and the isocyanide. TP3 plays the catalytic role by acidic activation of the ketone to favor the imine formation.

### 2.1.2 Steroids as amine and carboxylic acid components: Several groups have employed steroidal substrates as amino and

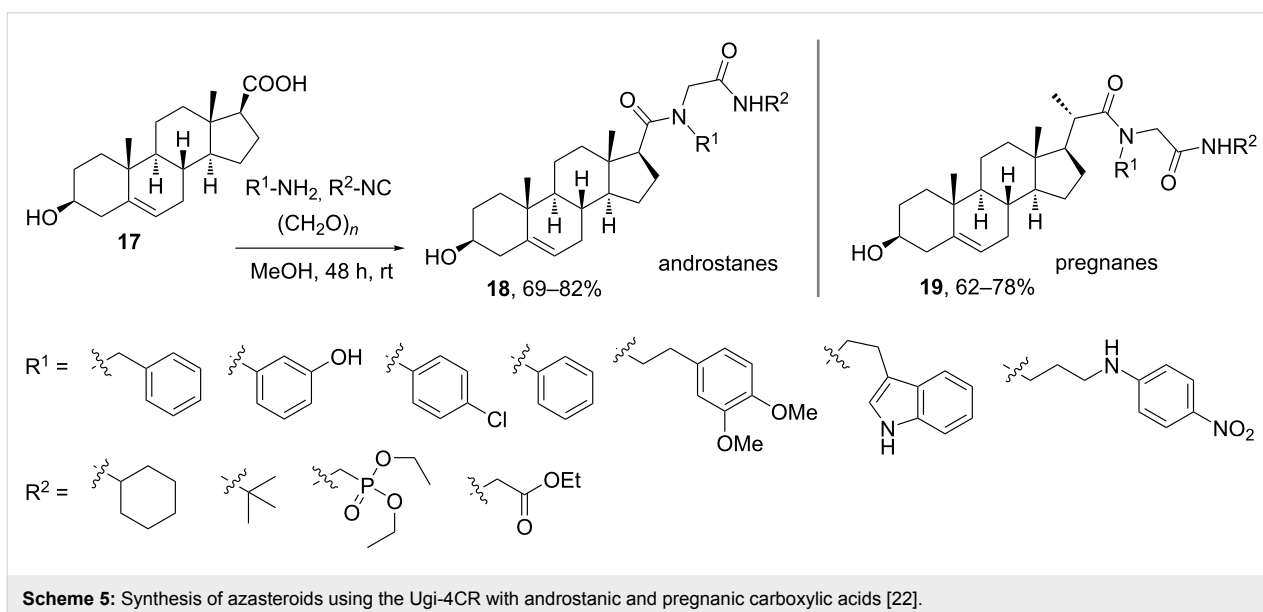
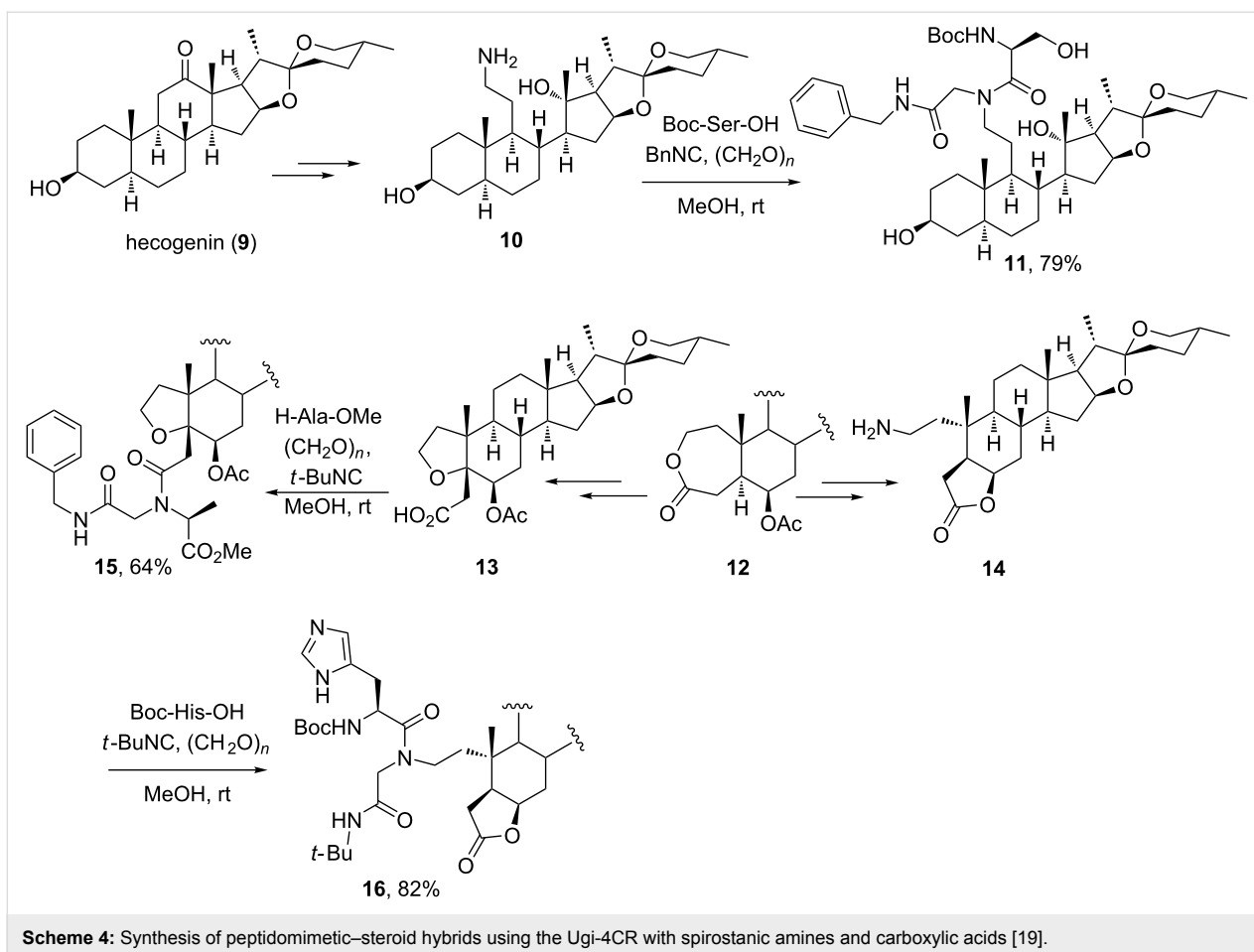
carboxylic acid components of the Ugi-4CR, which is indeed one of the MCRs of major incidence in the field of steroid chemistry. Rivera and co-workers were the first to employ this 4CR for the conjugation of amino acids to steroids [19] as part of a general program for the synthesis of peptidomimetic-steroid hybrids [20,21]. As shown in Scheme 4, the authors developed methods for the functionalization of spirostanoic steroids and their further conjugation to amino acids by means of the Ugi-4CR. Thus, seco-steroidal amine **10** – derived from the steroidal sapogenin hecogenin (**9**) – was ligated to Boc-protected serine in presence of paraformaldehyde and benzyl isocyanide to form hybrid **11** in good yield. Similarly, the spirostanoic lactone **12** was transformed into spirostanoic acid **13** and amine **14**, which were next ligated to alanine methyl ester and Boc-histidine leading to the amino acid-steroid conjugates **15** and **16**, respectively. This approach was also employed for the ligation of amino acids to spirostanoic seco-steroids at ring B and for the simultaneous incorporation of two amino acid residues [19].

Ramírez and co-workers have extended the application of the Ugi-4CR to the diversity-oriented functionalization of androstanic and pregnanic steroids using a carboxylic acid group at the side chain [22,23]. As shown in Scheme 5, the implementation of the Ugi-4CR with a variety of amines and isocyanides – keeping formaldehyde as the oxocomponent – enabled the generation of azasteroid libraries based on androstanic (**18**) and pregnanic (**19**) skeletons. These azasteroids, in which one or more nitrogen atoms are present in the side chain, were designed as promising compounds since such classes of antifungal steroids were known in the literature.

Some of the resulting azasteroids showed inhibitory effects on the growth of fungi such *Fusarium lateritium* (causal agent of chlorotic leaf distortion in sweet potato) and *Fusarium virguliforme* (causal agent of sudden death syndrome in soy bean),



**Scheme 3:** Multicomponent synthesis of a heterocycle-steroid hybrid using a ketosteroid as carbonyl component [18].



without exerting *in vitro* toxicity on mammalian cells. Another interesting result came out from the comparison of the biological activity between homologous pairs **18** and **19** [22]. For ex-

ample, the pair of androstanic and pregnanic derivatives incorporating  $R^1 = \text{Phe}$  and  $R^2 = t\text{-Bu}$  showed significant activity against both fungi tested, but the compounds derived from

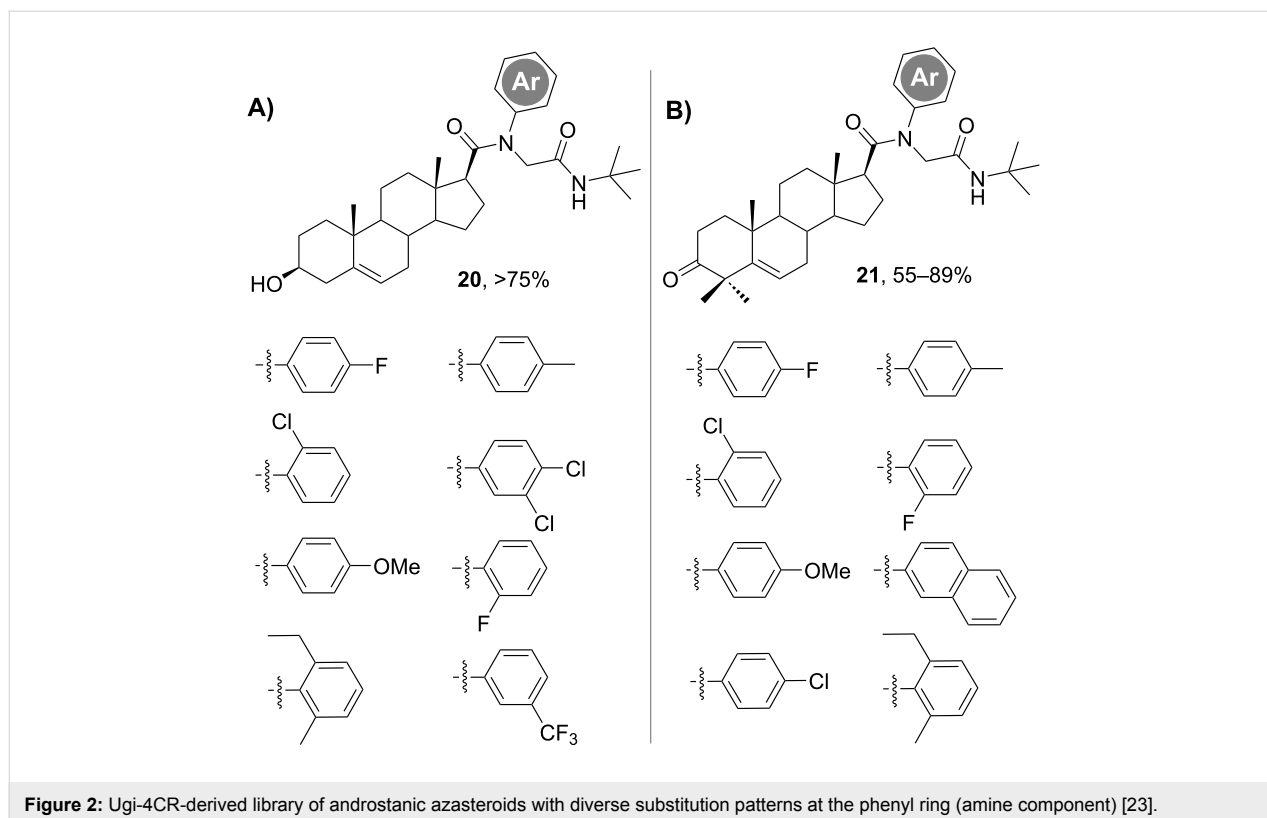
benzylamine (i.e.,  $R^1 = \text{Bn}$ ) did exhibit either a low or null biological activity for the fungi. This could indicate that the antifungal properties of such azasteroids very much depend on the phenyl moieties attached to the side chain. This type of biological comparison could be established because of the versatility of the synthetic strategy based on the MCR tool.

On the other hand, the family of compound class **18** was evaluated for the inhibition of the viral multiplication and for their implication in intracellular localization of viral glycoproteins [23]. Two compounds showed antiviral effects against herpes simplex virus 1 (HSV-1, KOS strain) and vesicular stomatitis virus (VSV). The key structural characteristics of both compounds are the presence of a phenyl moiety as  $R^1$  and a *t*-Bu group at the terminal amide. Thus, using the same synthetic strategy as shown in Scheme 5, Dávola et al. [23] synthesized a family of new Ugi reaction-derived androstatic azasteroids with a much more diverse substitution pattern at the phenyl moiety (Figure 2A).

The small library of compounds enabled a better understanding of the structural factors determining the antiviral activity versus the cytotoxic one, with the major effect found for substituents at the *para*-position [23]. Eventually, this work allowed the design of new compounds with antiviral activity and reduced cytotoxic effects by changing the type and position of the substitu-

ent. Such small structural changes could be implemented in a rapid manner because of the easy setup of the MCR approach.

To get a deeper insight into the biological effect of Ugi-derived steroids, additional libraries were synthesized by Ramírez, Barquero and co-workers following the concept of varying the amine component and using the steroid as carboxylic acid [24,25]. For example, based on the structure of 4,4-dimethylsterols – compounds that are involved in specific physiological processes – this group used the Ugi-4CR chemistry [24] for the subsequent diversification of the androstatic family of azasteroids, again focusing on the installation of substituted phenyl groups (derived from the amine component) that gave such good results in their previous work [22,23]. The library of androstatic derivatives **21** (Figure 2B) and their reduced analogues bearing the  $3\beta$ -hydroxy group were biologically tested showing antifungal activity against *Fusarium virguliforme* and *Fusarium solani*. The generation of this compound library suffered from the formation of the Passerini reaction byproducts – likely due to the poor reactivity of the substituted anilines as amino components of the Ugi-4CR. Nonetheless, the Passerini products were also evaluated and provided important information of the structure–activity relationship [24]. An additional library was built by performing the Ugi-4CR at a carboxylic acid placed at C-16 [25], a position never before derivatized by MCRs as its substitution is less common in



**Figure 2:** Ugi-4CR-derived library of androstatic azasteroids with diverse substitution patterns at the phenyl ring (amine component) [23].

natural steroids. The authors extended the studies of the C-16 Ugi-derivatized steroids as antiviral agents and found compounds with inhibitory effects against HSV-1 spread (on the wild type and on the acyclovir-resistant strains), as they interfered with late steps in the viral replication cycle [25].

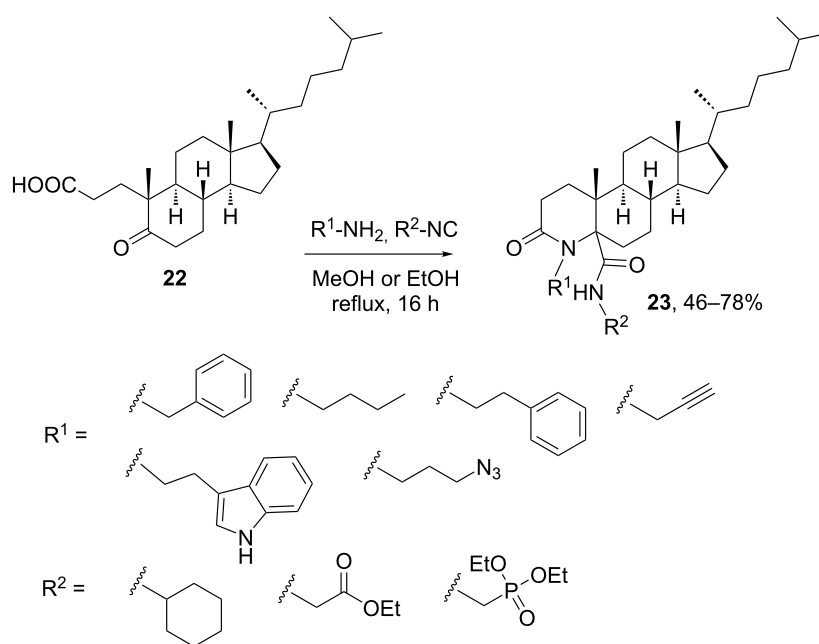
An interesting feature of the Ugi reactions shown with keto-steroids having additional carboxylic and aldehyde groups (see Scheme 1 and Figure 2B) is the lack of side reaction at the ketone functionality. This can be explained by the higher reactivity of the aldehyde functionalities upon imine formation with both aliphatic and aromatic amines. However, steroidal ketones can also participate in Ugi reactions if no additional, more reactive carbonyl components are present. As shown in Scheme 6, this has been demonstrated by Alonso et. al. [26] with the development of a multicomponent approach to obtain 4-aza-steroids using an intramolecular Ugi-4CR between a bifunctional steroidal ketoacid and different amines and isocyanides. Because of the poor reactivity of the steroidal ketone, the Ugi-4CR had to be conducted at reflux to obtain a good yield of Ugi-derived steroids, albeit the procedure generated a pair of diastereomers (epimeric at C-5) in almost equal amount. The stereoselectivity of the intramolecular MCR increased when a bulky isonitrile was used, e.g., diethyl phosphonate isocyanide. The configuration of C-5 in each stereoisomer was established using NOESY experiments and theoretical models.

The main limitation of this approach was the impossibility to incorporate both aromatic and sterically hindered amines (e.g.,

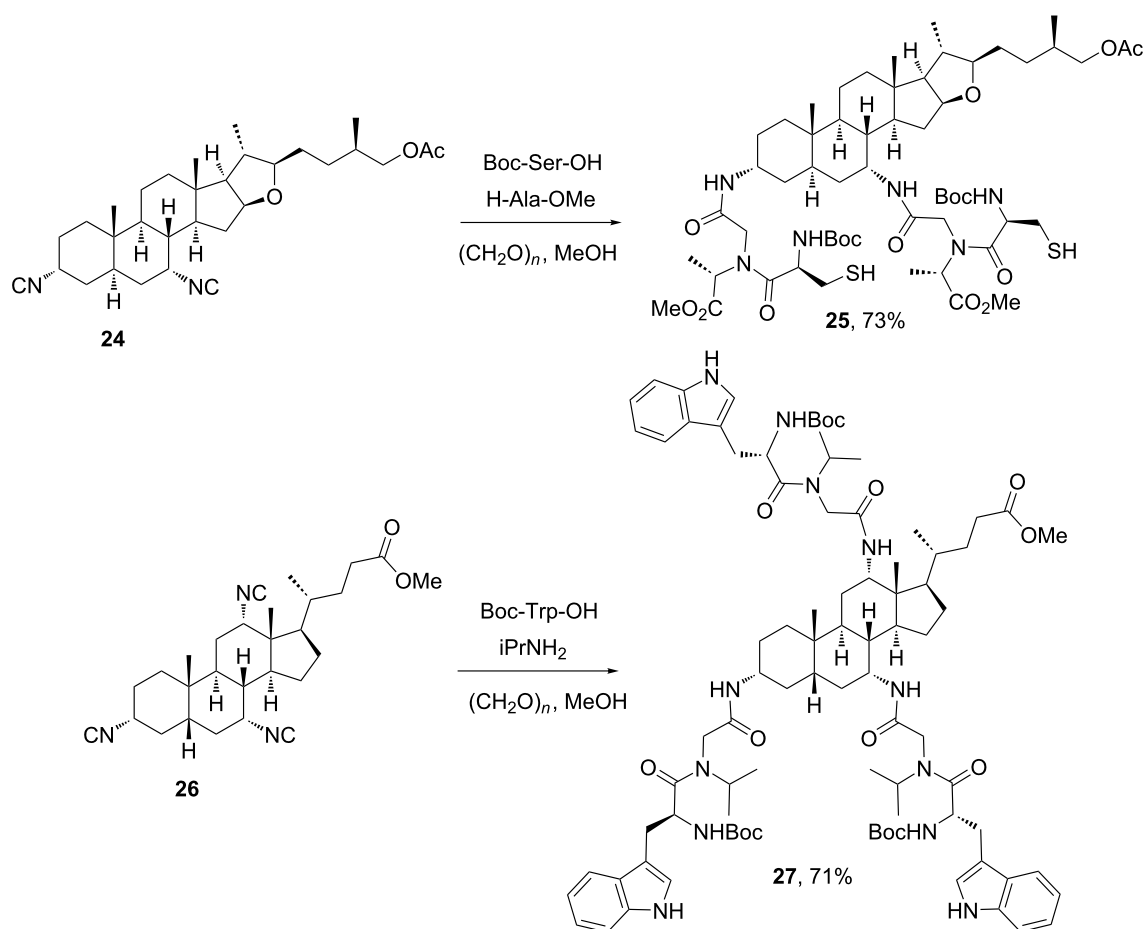
*tert*-butylamine). Besides the reports of Rivera's and Ramirez's groups on Ugi-4CRs with spirostanoic, androstanoic, pregnanoic and cholestanic carboxylic acids, later on Chowdhury and co-workers published a similar strategy for the multicomponent derivatization of cholestanes using microwave assisted Ugi-4CR [27].

**2.1.3 Steroids as the isocyanide component:** To our knowledge, the first synthesis and application in MCRs of steroidal isocyanides was reported by Wessjohann and co-workers [28] during their work on multicomponent macrocyclizations with steroidal building blocks. After that, this group focused on the synthesis of steroidal podands using multiple MCRs for the installation of peptidomimetic chains at different positions of the steroidal skeleton, which enabled rigidifying the pendant peptide chains [29]. Scheme 7 depicts two selected examples of this work, showing the possibility of incorporating isocyanide groups at furostanoic and cholanoic steroids and their subsequent utilization in the Ugi-4CR with monoprotected amino acids (used either as amino or carboxylic acid components) and formaldehyde as fixed oxo component. Amazingly, the Ugi-4CR of steroidal trisocyanide **26** with three equivalents of Boc-tryptophan allowed the formation of twelve covalent bonds in one-pot, leading to a remarkably complex amino acid-steroid hybrid **27** in very good yield [29].

After the pioneering work of Wessjohann and co-workers, other groups relied on the functionalization of steroids with isocyanide groups for their subsequent derivatization by



**Scheme 6:** Synthesis of 4-azacholestanes by an intramolecular Ugi-4C-3R [26].

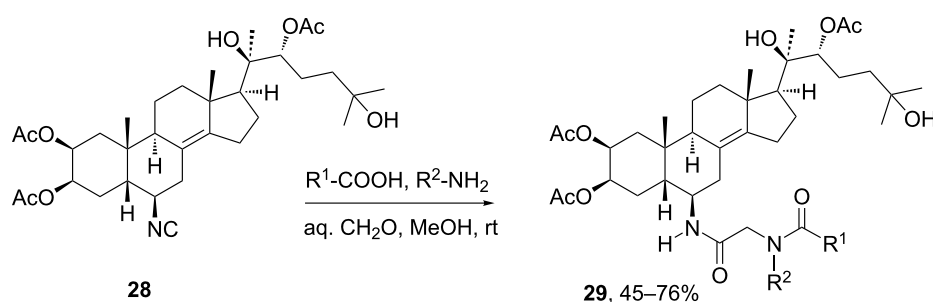


**Scheme 7:** Synthesis of amino acid-steroid hybrid by multiple Ugi-4CR using steroidal isocyanides [29].

isocyanide-based MCRs. Thus, Lesma et al. [30] reported an interesting example of generation of an Ugi product at ring B using a steroidal isocyanide featuring an insect hormone ecdysteroid structure. As shown in Scheme 8, a set of Ugi-4CR-derived ecdysteroids **29** was produced by variation of the amine and carboxylic acid components, keeping formaldehyde as oxo component to obtain a single stereoisomer. The library was also

integrated by the Ugi-4CR products derived from the 6β-ecdysteroidal amine (also used as precursor of isocyanide **28**), while all compounds were evaluated as antiproliferative agents against T-leukemia cell line.

A very recent example of a highly diastereoselective Ugi-type MCR was reported by Rivera, Paixão and co-workers using a



**Scheme 8:** Synthesis of ecdysteroid derivatives by Ugi-4CR using a steroidal isocyanide [30].

steroidal isocyanide [31]. As shown in Scheme 9, the procedure comprised the organocatalytic asymmetric synthesis of the chiral bifunctional substrate **30** bearing an masked aldehyde and an enol functionality, which was subsequently reacted with isocyanide **31** – derived from cholesterol – and 3,5-dimethoxyaniline leading to the steroid–tetrahydropyridine hybrid **32** in good yield and excellent diastereoselectivity. As previously proven by the authors in their synthetic program on organocatalytic multicomponent approaches [32] not only the chiral steroidal isocyanide but also the bifunctional component **30**, used in enantiomerically enriched form, plays a crucial role in the high stereoselection.

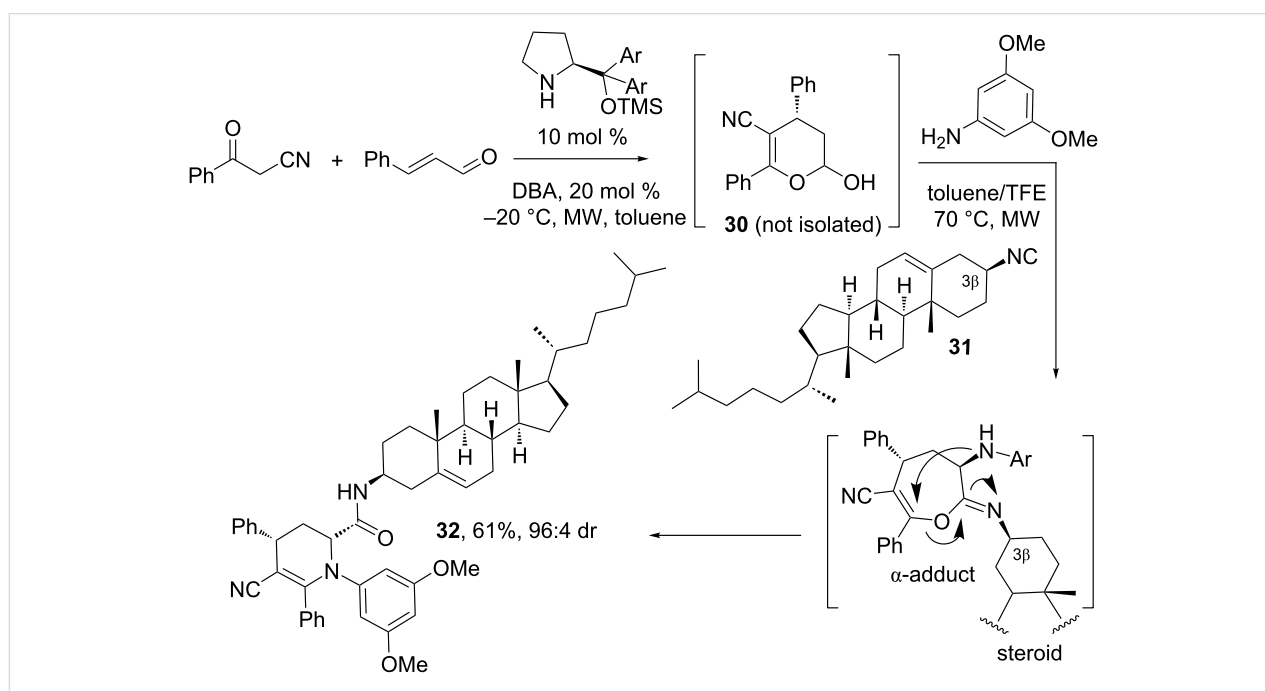
The mechanistic insights of this class of MCR were disclosed in the original publication [31]. In short, the organocatalytic conjugated addition of benzoylacetonitrile to cinnamaldehyde generates the hemiacetal **30**, which next initiates the multicomponent sequence upon condensation with the aniline and formation of the imine, eventually occurring as a stable cyclic aminal. The attack of the steroidal isocyanide **31** to the imine (or aminal) leads to the stereoselective formation of the  $\alpha$ -adduct intermediates, which rearranges to the final tetrahydropyridine ring **32**.

Besides the use of steroids as oxo, amine, carboxylic acid and isocyanide components, there is a very early report by Dumestre et al. [33] describing the participation of a nitrosteroid and an acylating agent in a novel isocyanide-based MCR. Thus, the reaction of a nitrosteroid – derived from 16-dehydropregne-

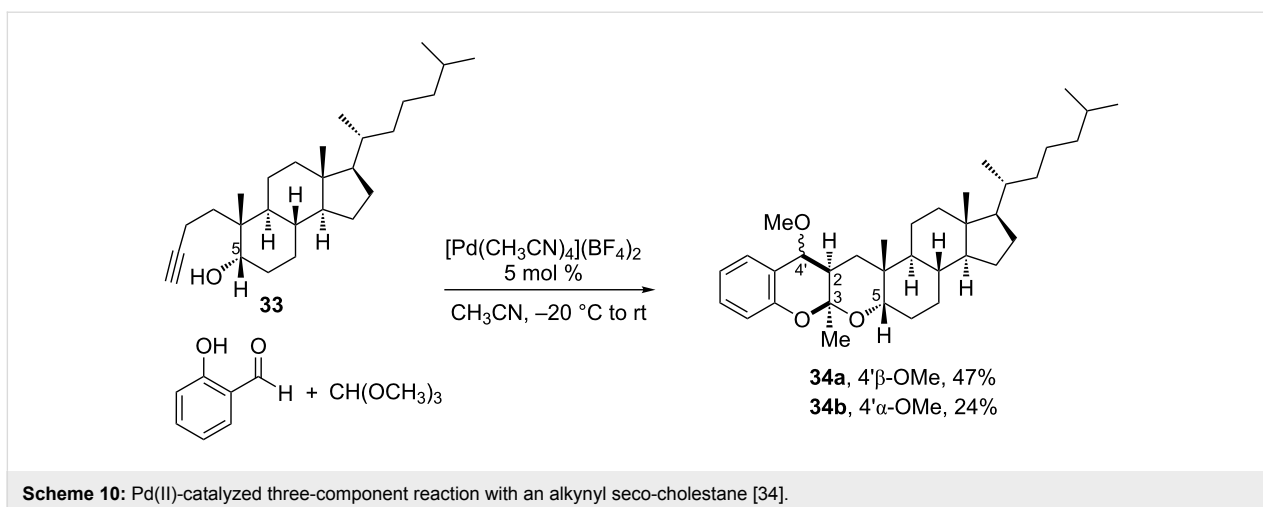
nalone – with acetic anhydride and *tert*-butyl isocyanide furnished an acetyl  $\alpha$ -oximinoamide moiety at the steroidal side chain. Albeit this reaction did not find later synthetic applications, it encompasses a nice example of the diversity of MCRs that can be applied to diversify steroidal skeletons.

## 2.2 Miscellaneous MCRs for steroid derivatization

Despite isocyanide-based MCRs have been the main classes of multicomponent transformations used in steroid modification, in the last years various MCRs have emerged as suitable procedures for the diversification of this family of biomolecules. A remarkable example is the report of Iglesias-Arteaga and co-workers [34] on the application of the Pd(II)-catalyzed three-component reaction (3CR) developed by Barluenga et al. [35] to steroids. The original Barluenga's 3CR comprises the reaction of salicylaldehyde with an alkyl orthoformate and 4-pentyn-1-ol to obtain a 4-alkylchroman spiroketal as a single diastereomer. However, as shown in Scheme 10, the employment of alkynyl-4,5-secocholestan-5-ol **33** in such a metal-catalyzed MCR led to the steroidal chroman-ketal **34** as a mixture of epimers at the center bearing the methoxy group, instead of the expected chroman spiroketal. The authors proposed the initial formation of a 6-membered enol ether, which may subsequently undergo either a stepwise Pd(II)-catalyzed cascade process or a [4 + 2] cycloaddition reaction, both providing the *cis* stereochemistry at C-2 and C-3. When the reaction was carried out with the epimer of substrate **33** (having the 5 $\beta$ -hydroxy group), the *cis* stereochemistry was also achieved at the newly formed C-2 and C-3,



**Scheme 9:** Stereoselective multicomponent synthesis of a steroid–tetrahydropyridine hybrid using a chiral bifunctional substrate and a cholestanic isocyanide. DBA: 3,5-dinitrobenzoic acid [31].

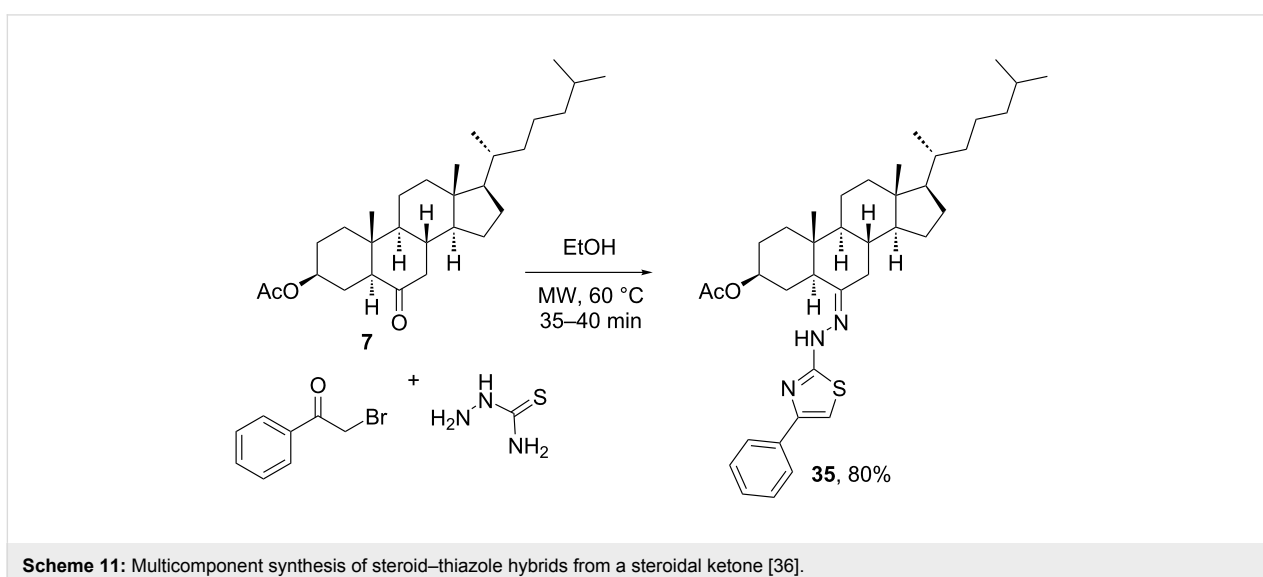


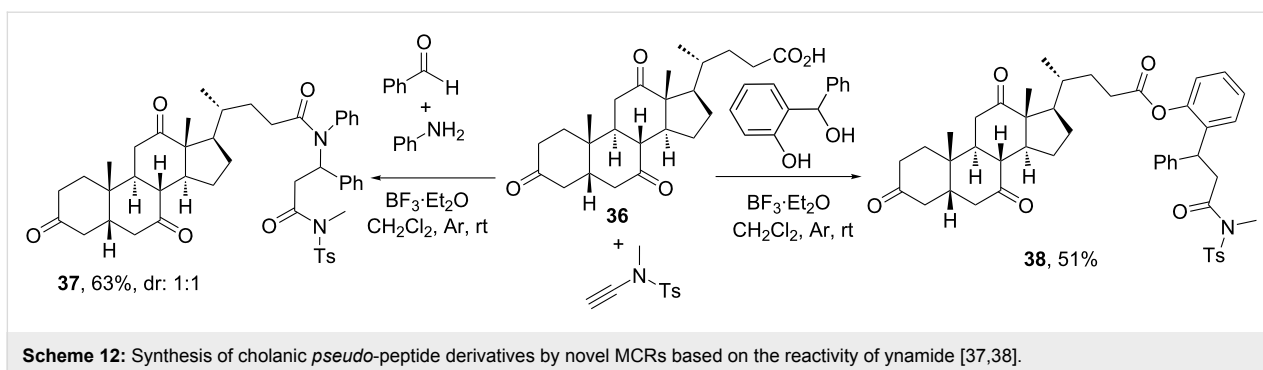
but with the tetrahydropyran ring having  $\alpha$  orientation. A mixture of epimers at position 4' was also obtained when using the C-5 epimer of substrate **33**.

Asif et al. [36] developed another 3CR for the synthesis of steroidal thiazole derivatives. As shown in Scheme 11, cholestanic ketone **7** was reacted with a thiosemicarbazide and 2-bromo-1-phenylethan-1-one under microwave irradiation to form the steroid–thiazole hybrid **35** in very good yield. As previously mentioned, due to the poor reactivity of steroidal ketones and their imine derivatives, most MCRs with ketosteroids described in the literature required a high temperature set by classic heating or microwave irradiation.

Using cholic acid as carboxylic acid component, Cui and co-workers [37] developed a novel MCR resembling the Ugi-4CR, but relying on the reactivity of ynamides as surrogates of

the isocyanide component. Ynamides are alkynes with a carbon–carbon triple bond attached to a nitrogen atom that gives them both nucleophilic and electrophilic properties. This dual reactivity is similar to that shown by isocyanides, as they may react with iminium ions and carboxylates as isocyanides do. However, in comparison with the typical Ugi-4CR where the isocyanide component acts as a one-carbon center, in this reaction the ynamide compound has a two-carbon center role. As shown in Scheme 12, the reaction of dehydrocholic acid (**36**), an amine and an aldehyde with the key ynamide component provided a new type of *pseudo*-peptidic steroid **37**, obtained as a 1:1 mixture of diastereomers. Besides steroids, the authors proved that a wide variety of components participate in this reaction, unfortunately always rendering mixtures of diastereomers when pro-chiral aldehydes were employed [37]. Also differently from the Ugi-4CR, this MCR requires the use of a Lewis acid like  $\text{BF}_3 \cdot \text{Et}_2\text{O}$  for a suitable activation of the imine.





Based on the same idea of exploiting the reactivity of ynamides, Cui's group developed a 3CR wherein an *o*-hydroxybenzhydryl alcohol was used in place of the aldehyde or imine components upon reaction with ynamide and a carboxylic acid [38]. Scheme 12 depicts the implementation of this 3CR with dehydrocholic acid **36** to furnish steroid derivative **38** functionalized at the side chain. This reaction incorporated an ester group at the position where the analogous 4CR created a tertiary amide, because of the similarities between the Passerini and Ugi reactions.

### 3 Synthesis of steroid-fused heterocycles

The modification of the steroidal nucleus by attaching a heterocycle to this hydrophobic scaffold has been traditionally used as an effective way to modulate the biological activity of these biomolecules. In this regard, pentacyclic steroids are a class of pharmacologically relevant steroid derivatives in which the steroid-ring system has a fused heterocyclic or carbocyclic ring. The fifth ring is typically fused to the steroid on ring A, B or D and some times more than one ring is fused, thus generating hexacyclic or heptacyclic steroids. To our knowledge, there are no reports of fused heterocyclic or carbocyclic rings on the ring C of the steroid. In this section, we discuss different reports on the synthesis of steroid-fused heterocycle using MCRs.

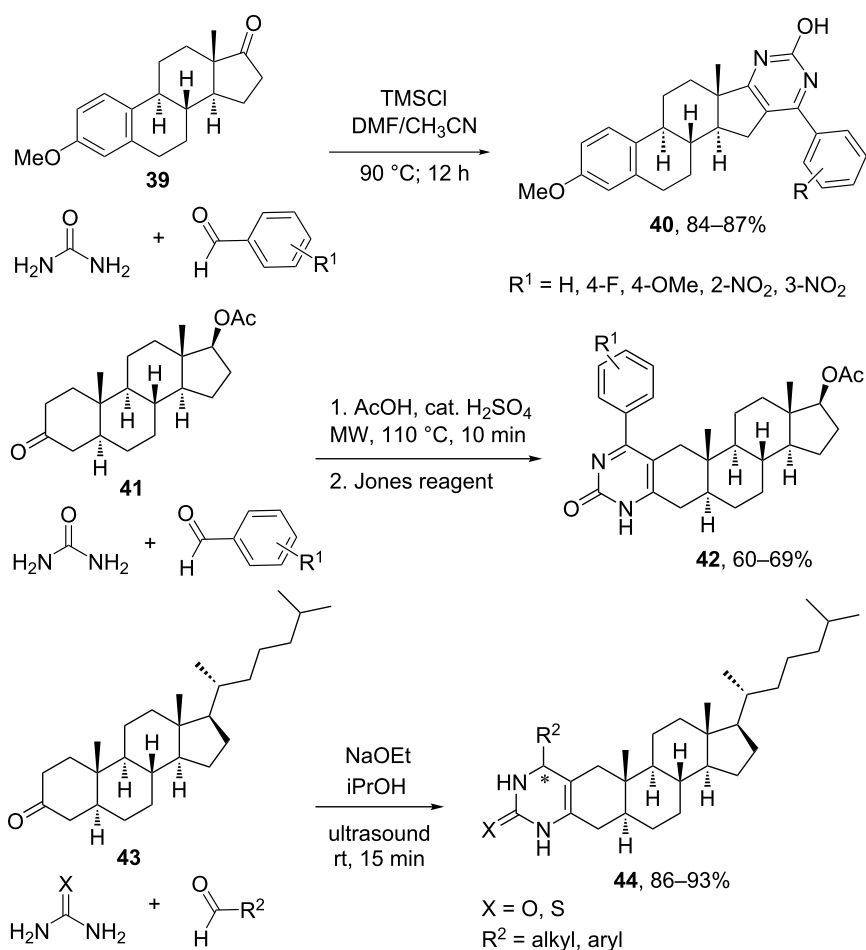
Wang et al. [39] developed a synthetic route based on the Biginelli reaction for the preparation of steroidal derivatives with a pyrimidine moiety fused to ring D. This heterocycle moiety appears in different biologically active steroids fused to ring D, and previous non-MCR methods had been reported for the creation of libraries of such hybrid compounds [40]. The Biginelli reaction reported in 1893 comprises the acid-catalyzed condensation of ethyl acetoacetate, benzaldehyde and urea to generate 3,4-dihydropyrimidin-2(1*H*)-one [41]. From that time, the reaction was extended to Lewis-acid catalysis and the use of other solvents such as methanol or aprotic solvents such as THF, dioxane, acetonitrile, etc. Because the reaction rate is slow at room temperature, it needs activation by heating or other non-traditional methods such as ultrasound, micro-

wave, IR irradiation and photochemical irradiation, as it will be exemplified below.

In terms of reactants, the reaction seems to work best using aromatic aldehydes with both electron-withdrawing and donating substituents in *ortho*, *meta* and *para*-positions. In addition, not only acetoacetates can be employed, but the reaction can be extended to ketones, thioesters, benzoylactic esters, acetoacetamides, alkylic or cyclic  $\beta$ -diketones, etc. The urea component has the main structural restrictions, since monosubstituted alkyl ureas work well but thioureas have provided much lower yields. Wang et al. produced a library of steroidal [17,16-*d*]pyrimidine derivatives such as **40** employing a particular extension of the Biginelli reaction based on the use of 17-ketosteroids and chlorotrimethylsilane (TMSCl) as catalyst, which enables the formation of the nucleophilic enolate that attacks either benzaldehyde or its urea imine derivative [39]. Varied ketosteroids were employed, including methylestrone **39**, dehydroepiandrosterone acetate and epiandrosterone acetate, etc., all providing excellent yields of steroidal pyrimidines after 12 h of reaction at 90 °C (Scheme 13). The reaction sequence of this multicomponent protocol comprises the initial formation of the Biginelli product, followed by aromatization under air to furnish the heterocyclic ring fused at positions 16 and 17.

In a recent report, Baji et al. [42] utilized a modified Biginelli-3CR between ketosteroid **41**, urea and different benzaldehyde derivatives for the synthesis of steroid ring A-fused pyrimidines **42**. In this case, the heterocyclic ring was produced by a second step using the strong oxidizing Jones reagent, because the oxidizing power of sulfuric acid was not enough to achieve oxidation. Interestingly, the use of microwave irradiation instead of classic heating allowed obtaining the Biginelli product in only 10 min, instead of 12 h as required for the synthesis of pyrimidines **40** (Scheme 13).

An alternative setup of Biginelli-3CR with steroids was reported by Boruah and co-workers [43] using ultrasound assistance instead of microwave irradiation or thermal heating. In



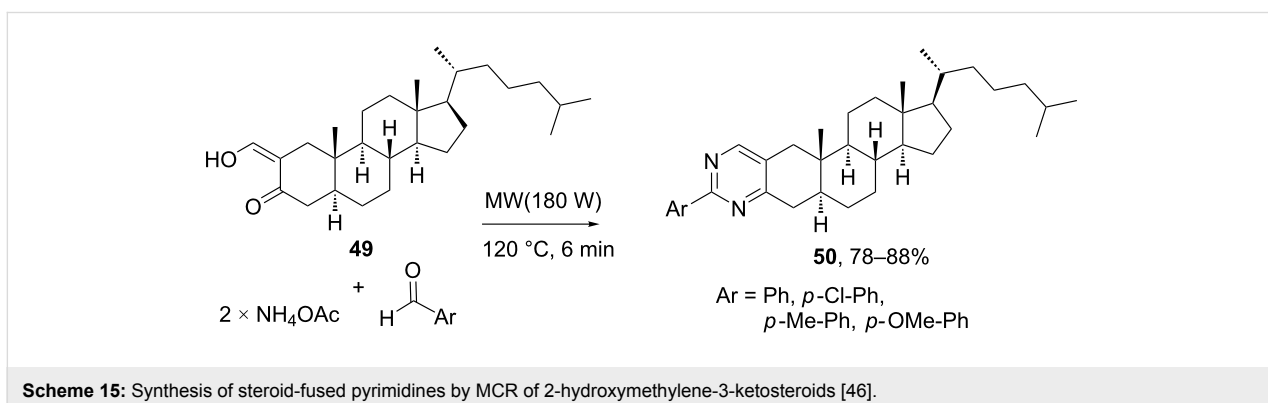
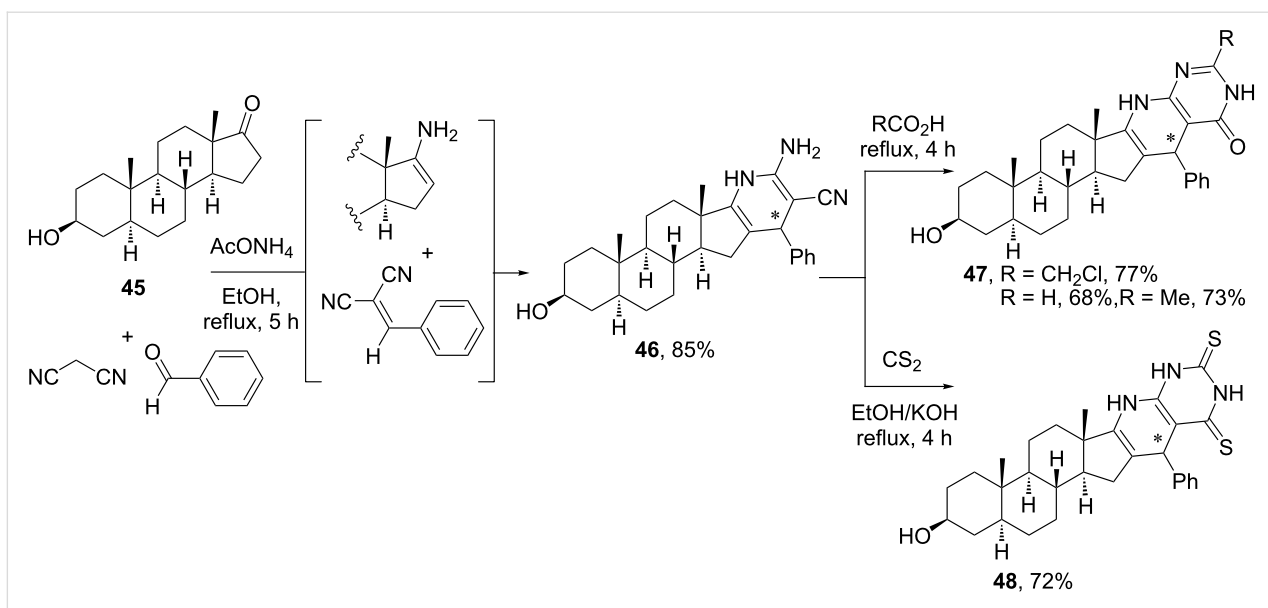
**Scheme 13:** Synthesis of steroid-fused pyrimidines and pyrimidones using the Biginelli-3CR [39,42,43].

this case, the reaction between cholestanic ketone **43**, an alkyl or arylaldehyde, and urea or thiourea could be conducted under ultrasound irradiation using sodium ethoxide as catalyst, thus generating steroid ring A-fused 3,4-dihydropyrimidinones and 3,4-dihydropyrimidinethiones **44** in very good yields.

Mohamed et al. [44] reported a 4CR for the synthesis of pyridopyrimidines fused to ring D of androstanic steroids. Such heterocyclic moieties are of interest because of their pharmacological activity, for example, as anti-inflammatory agents. Employing epiandrosterone and benzaldehyde as oxo components, ammonium acetate and malononitrile as C-nucleophile, the authors produced 2-amino-3-cyano-1,4-dihydropyridine **46** fused to the androstane at positions 16 and 17 (Scheme 14). The MCR proceeds by the condensation of malononitrile with benzaldehyde to form the benzylidene malononitrile adduct, and of the ketosteroid with ammonium to form the steroidal enamine, which cyclizes with the benzylidene to furnish the 1,4-dihydropyridine scaffold. As depicted in Scheme 14, compound **46** was later subjected to a variety of post-MCR cycliza-

tions, including the reaction with carboxylic acids to form the fused steroidal pyridopyrimidinones **47** and with carbon disulfide to form pyridopyrimidinedithione **48** in very good yields. Overall, five different components are incorporated in the reaction sequence, whereas acid chlorides, anhydrides, hydrazine, etc., could also be employed in the post-MCR cyclization [44]. The library of steroidal heterocycles was tested against oxidative stress and neuroinflammation due to cerebral injection of lipopolysaccharide endotoxin, with some compounds showing antioxidant and antineuroinflammatory activities. The same group employed this 4CR with cholestan-3-one for the construction of 2-amino-3-cyanodihydropyridine scaffold fused to ring A of the cholestane system [45].

Also targeting steroid-fused pyrimidines, Boruah's group developed a solid-phase MCR between 2-hydroxymethylene-3-ketosteroids, aromatic aldehydes and ammonium acetate [46]. As shown in Scheme 15, the reaction was carried out with steroid **49** and different aldehydes to furnish the set of compounds **50** in good to excellent yields. The proposed mecha-



nism begins with the formation of the  $\beta$ -aminoketoimine by condensation of the steroid with two molecules of ammonia, followed by the reaction with arylaldehyde and intramolecular cyclization to a dihydropyrimidine skeleton, which suffers oxidation to the aromatic heterocyclic ring

Boruah and co-workers extended the same approach to different steroidal starting materials and varied the substituents in the arylaldehyde component to investigate the steric and electronic effects on the yields of the steroid-fused pyrimidine products [43]. Thus, the yield increases when the substituent of the arylaldehyde is in *para*-position, but decrease with the substituent in *ortho*-position, likely due to steric hindrance that limits the cyclization process. In terms of electronic effect, electron-withdrawing groups (e.g., F, Cl, Br, NO<sub>2</sub>) favor the heterocyclization, but electron-donating groups like CH<sub>3</sub> and OMe does only partially. Both steric and electronic effects can be explained from the reactivity of the diimine intermediate. An elec-

tron-withdrawing group promotes the nucleophilic attack of the ketoimine N by increasing the partially positive charge of the imine C. In general, Boruah's group has been very active in the synthesis of nitrogen heterocycles such as pyrimidines, pyrazolopyrimidines and disubstituted pyridines fused to rings A and D of steroids [47-49].

Thus far, most applications of MCRs in steroid derivatization aimed at producing derivatives for screening their biological and pharmacological properties. A different example is the utilization of MCR-derived steroids as analytical patterns of petroleum samples. Steroids are present as "biomarker" components of petroleum, fused with asphaltene, which are structurally complex molecules with polycyclic aromatic or partially aromatic hydrocarbons, heteroatoms, alkyl chains and polar functions. As asphaltene, such steroid-asphaltene derivatives are constituents of the heaviest fractions of petroleum. Understanding the physical characteristics of these derivatives allows

their removal from the heavy oil fractions; such compounds are too complex for analysis at a molecular level, so it is important to synthesize analytical standards for their study.

In this context, Schulze et al. optimized a multicomponent cyclocondensation reaction [50,51] between 5 $\alpha$ -cholestan-3-one (**43**), aromatic aldehydes and 2-aminoanthracene (**51**) for the generation of steroidal naphthoquinolines as synthetic asphaltene models for the study of their physical properties. As shown in Scheme 16, the synthetic approach was based on Kozlov–Wang MCR [52], in which an aromatic aldehyde, 2-aminoanthracene and tetrahydropyran-4-one react in the presence of I<sub>2</sub> as catalyst. The mechanism follows the initial formation of the imine compound between the aldehyde and the arylamine, followed by an imino-Diels–Alder reaction with the enolate generated from the ketosteroid. The reaction is highly regioselective for the enolization of the ketone, thus giving the ring A-fused pyridine at positions 2 and 3. This iodine-promoted MCR tolerates both electron-donating and electron-withdrawing groups on the aromatic aldehyde, thus leading to varied, optically active asphaltene model compounds that could serve as structural mimetics of known components of heavy oils.

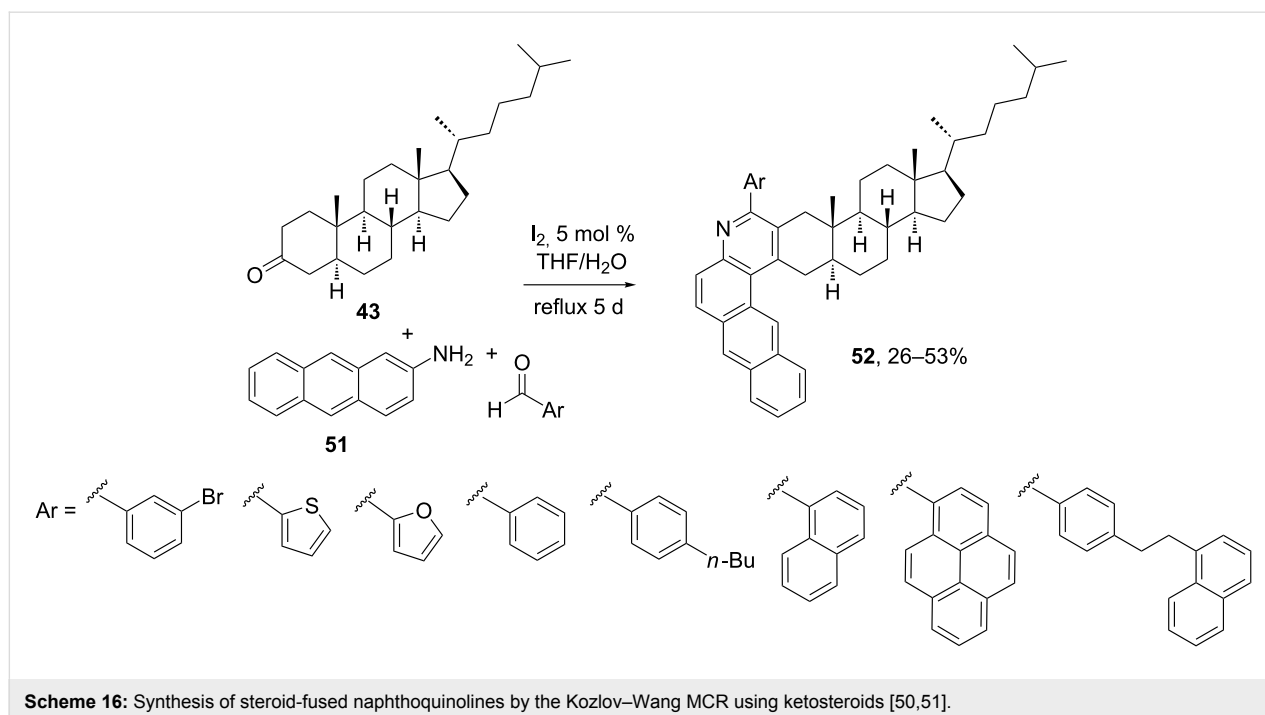
Besides the fusion of the steroidal nucleus to heterocycles by MCRs, there is a whole field of research developed by Tietze and co-workers in the 90's dealing with the construction of heterosteroids, D-homosteroids (steroids with all 6-membered rings) and azasteroids (steroids with a nitrogen atom in their

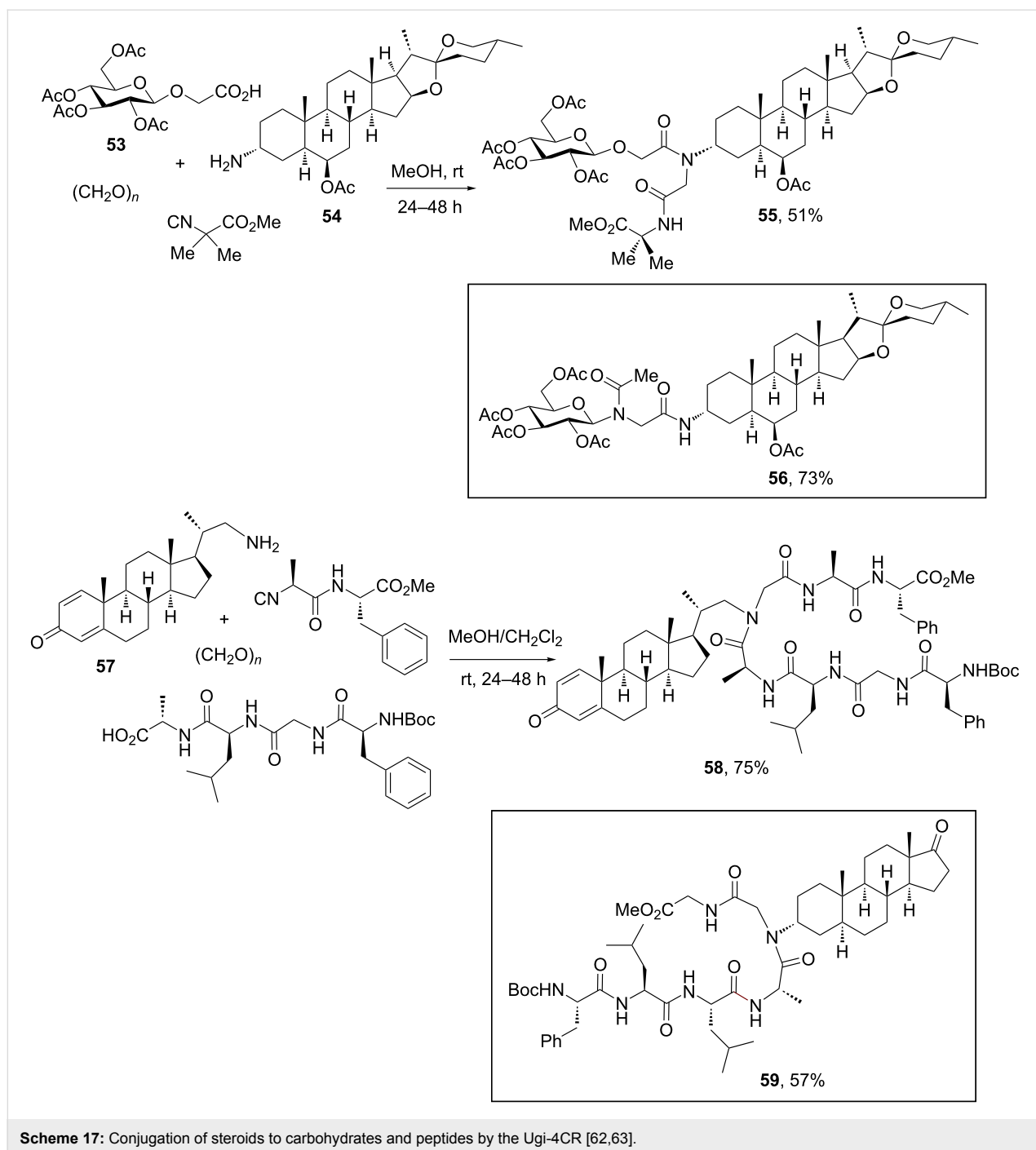
nucleus) [53,54]. This strategy employs domino Knoevenagel/hetero-Diels–Alder procedures for the assembly of such steroid mimics. However, we have decided not to include it in this review because several book chapters and reviews have already covered this chemistry [55,56].

#### 4 Conjugation of steroids to carbohydrates and peptides

The conjugation of steroids to other biomolecules such as carbohydrates and peptides represents a valuable strategy for providing new properties to the hydrophobic steroid skeleton. Naturally occurring steroid–sugar conjugates such as saponins have shown to possess physicochemical and biological features different from those of the two separate molecular entities [57,58]. Despite nature does not provide examples of steroid–peptide conjugates, chemists have produced such conjugates to be employed as protease-like artificial enzymes [59] as mimics of the natural cationic peptide antibiotics [60] or as a way to constrain peptide sequences in protein epitope conformations [61]. In this regard, the groups of Rivera and Wessjohann have pioneered the utilization of MCRs for the conjugation of oligosaccharides [62] and peptides [63,64] to steroids, thus producing unique types of steroidal conjugates.

Scheme 17 depicts the strategy toward steroidal conjugates using the Ugi-4CR, which allows accessing a high level of diversity by varying the combinations of the carbohydrate, peptide and steroidal functional groups reacting on the multi-





were chosen as model compounds for the preparation of Ugi-derived analogues, such as **55** and **56** suitable for biological evaluation [62]. Besides the glucose unit, other trisaccharidic moieties (e.g.,  $\beta$ -chacotrioside) could also be conjugated to functionalized spirostanoic steroids by Ugi-type MCRs.

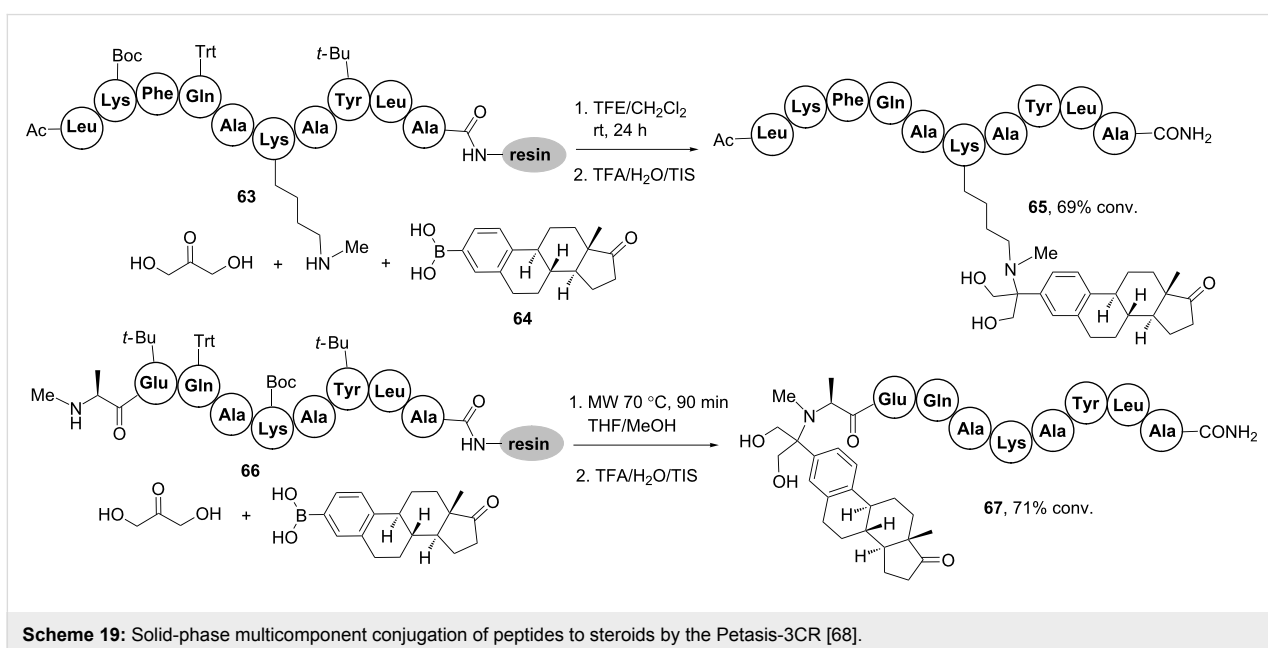
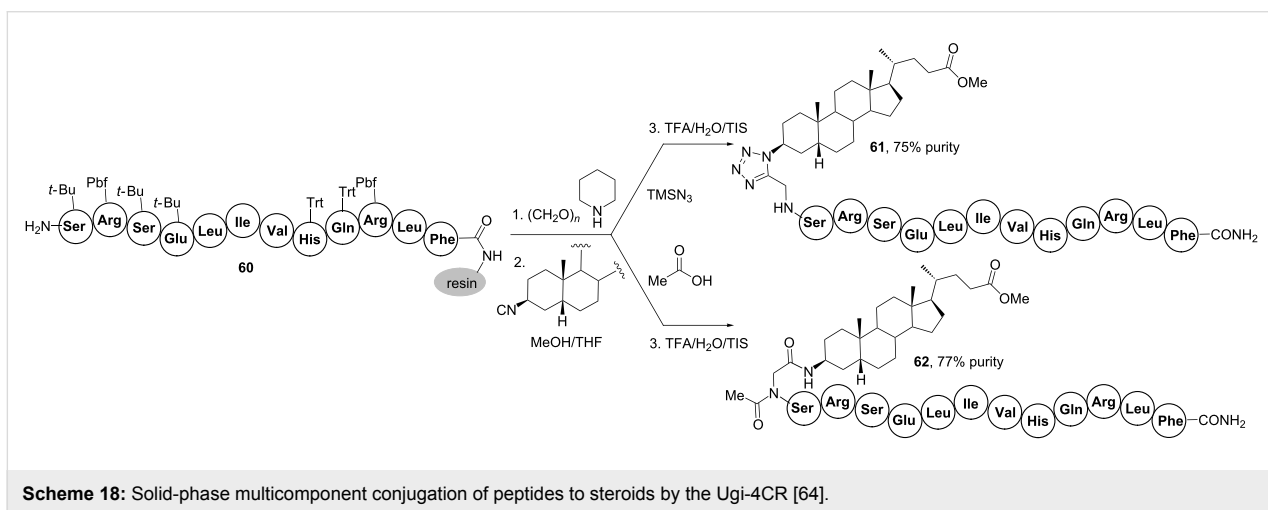
In addition, Rivera, Wessjohann and co-workers [63] extended the concept of the Ugi conjugation strategy to a distinctive family of peptide–steroid conjugate having the steroid skeleton

or the side chain attached to the peptide backbone as internal *N*-substituent. As shown in Scheme 17, amino steroids could be reacted in MeOH or MeOH/CH<sub>2</sub>Cl<sub>2</sub> at room temperature with peptide carboxylic acids and isocyanopeptides to furnish peptide–steroid conjugates such as **58** and **59**. Interestingly, the same solution-phase protocol proved to be equally effective for the conjugation of two different steroidal scaffolds [65], but it failed for the ligation of larger peptides to steroids due to the poor solubility of the former ones.

In this sense, Rivera's group introduced a solid-phase multicomponent procedure enabling the conjugation of steroids and lipids to peptides longer than 10 amino acid residues [64]. As shown in Scheme 18, the procedure comprised the growth of the antimicrobial peptide sequence **60** followed by the multicomponent incorporation of cholestanic steroids functionalized as isocyanide component. Two related on-resin Ugi-4CRs were employed, i.e., the Ugi-azide reaction based on hydrazoic acid as acid component that furnished peptide-steroid **61** and the classic one using acetic acid as carboxylic acid component, which led to conjugate **62**. These protocols enabled the introduction not only of a steroidal moiety at the *N*-terminus but also of lipid and affinity tags (e.g., biotin) [64]. Importantly, the effective implementation of on-resin Ugi-4CRs paved the way for the subsequent development of multicomponent macrocyc-

lizations permitting the introduction of PEGs, sugars and fluorescent labels at resin-linked peptides [66,67].

More recently, Wessjohann and Rivera [68] increased the diversity of MCRs that can be used to ligate peptides to steroids with the development of a novel multicomponent conjugation process based on the Petasis-3CR. The Petasis reaction [69] also known as the borono-Mannich reaction, is a MCR comprising the condensation of an aldehyde or ketone, an amine and an aryl/vinylboronic acid or ester. As illustrated in Scheme 19, the on-resin implementation of this reaction allowed, for the first time, the ligation of oligopeptides to biologically relevant steroids. Thus, resin-linked peptides **63** and **66** could be ligated either by Lys side chains or by the *N*-terminus to the estrone-derived boronic acid **64** using the on-resin Petasis-3CR in the



presence of dihydroxyacetone [68]. Peptido-steroids **65** and **67** were obtained in good overall yields after released from the resin using the cocktail TFA/H<sub>2</sub>O/triisopropylsilane (TIS), albeit the conjugation at the *N*-terminus required microwave irradiation due to the bulkier character of the amino component. Besides steroids, the method worked well with varied boronic acids, including those bearing fluorescent labels, lipids and PEG chains, thus providing a new class of biomolecular conjugates showing promise for the future development of peptide pharmaceuticals.

## 5 Multicomponent synthesis of steroidal macrocycles and cages

Since the beginning of this century, the field of macrocycle synthesis has witnessed the emergence of MCRs as effective ring closing procedures, including the cyclization of large scaffolds containing the rigid steroid skeleton. In this regard, Wessjohann can be considered as the pioneer of the synthesis of steroidal macrocycles using MCRs [12,13] including remarkable examples of huge macrocycles formed by the condensation of up to twelve components. Whereas the reports up to 2008 have been included in previous reviews [12,13] this section will cover those reports from 2009 on, with emphasis on multicomponent macrocyclization approaches leading to steroidal cages.

The first report of a MCR-derived steroidal macrocycles was described by Wessjohann et al. in 2005 as part of a synthetic program towards steroid-based supramolecular receptors [28]. There, steroidal diamines and diisocyanides derived from bile acids were employed in a procedure known as MiBs, i.e., multiple multicomponent macrocyclization including bifunctional building blocks. In a series of subsequent reports, Wessjohann's group exploited the MiBs strategy based on the Ugi-4CR for the assembly of topologically diverse steroidal macrocycles incorporating a variety of (seco)steroid skeletons [70-72].

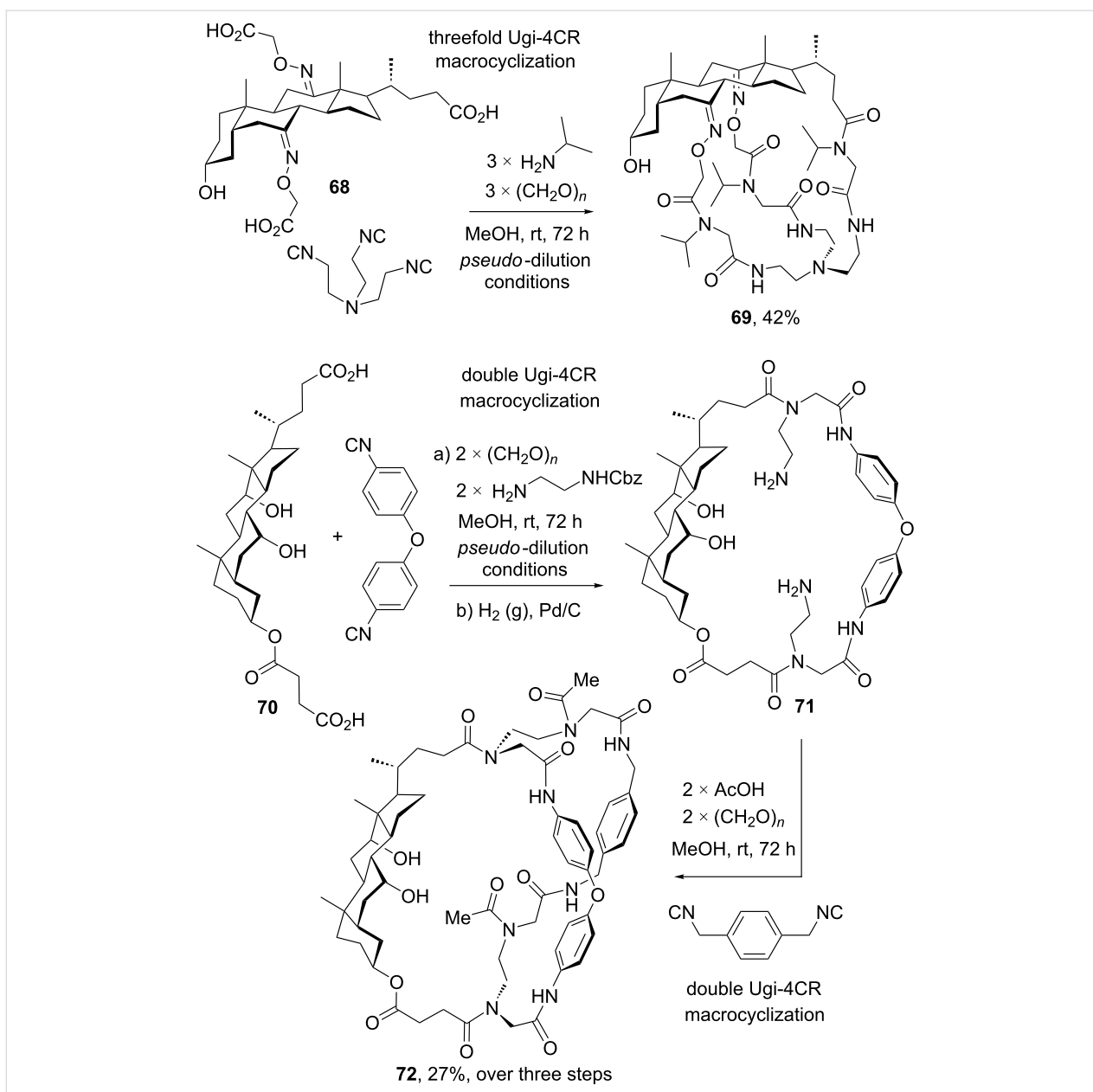
Probably the highest level of macrocycle complexity achieved in one-pot can be found in the multicomponent synthesis of steroidal cages multiple multicomponent macrocyclization [73]. As shown in Scheme 20, Rivera and Wessjohann expanded the MiBs concept to the development of a threefold Ugi-4CR-based macrocyclization between cholanic tricarboxylic acid **68** and an aliphatic triisocyanide in the presence of three equivalents each of paraformaldehyde and isopropylamine to furnish steroidal cage **69** in good yield. This multicomponent macrocyclization approach was implemented by setting up *pseudo*-dilution conditions [74], i.e., the simultaneous slow addition of two trifunctional components with syringe pumps to a stirring solution of the pre-formed imine (3 equiv), which avoids formation of

higher oligomers. Remarkably, such procedure was undertaken with formation of twelve covalent bonds and the incorporation of eight components in one pot. A few years later, the same authors described the implementation of a sequential MiBs strategy for the construction on hybrid macromulticycles including a steroidal skeleton as one of the tethers [75]. Scheme 20 illustrates one of the examples reported by Wessjohann's group, in which cholanic dicarboxylic acid **70** was subjected to an initial macrocyclization based on two Ugi-4CRs with a biaryl ether diisocyanide and two equivalents of paraformaldehyde and a monoprotected diamine. After the initial macrocyclization, steroidal macrocycle **71** was deprotected by removal of the Cbz groups and subsequently submitted to a second multicomponent macrocyclization protocol – in this case serving as diamino component – to render macrobicycle **72** in moderate yield over three steps. Despite the process was not conducted in one pot, this simple synthetic setup was employed to produce a set of very complex steroidal macrobicycles suitable for molecular and ion pair encapsulation [75].

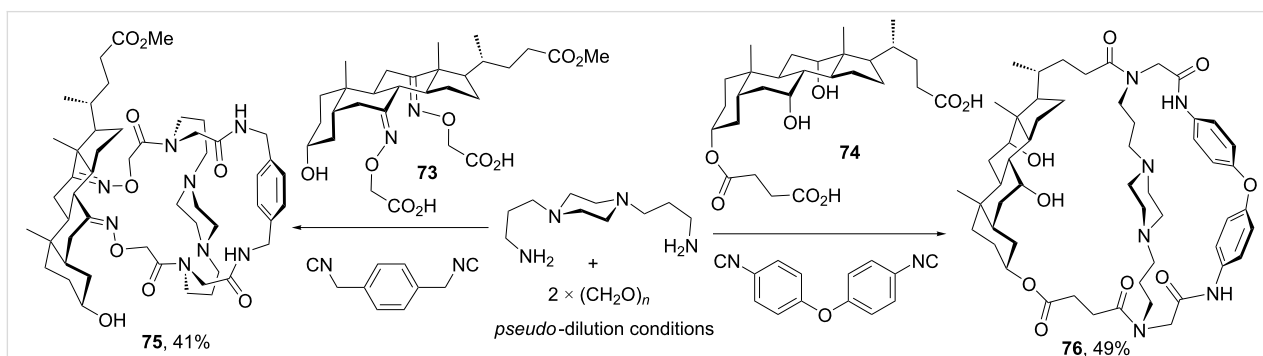
Aiming at producing a more efficient and straightforward method toward macrobicycles, Wessjohann and Rivera [76] implemented a double Ugi-4CR-based macrocyclization comprising the one-pot assembly of three different bifunctional building blocks, one of them of steroidal nature. Differently from any other MiBs approach, this procedure focuses on constructing the macrobicycle connectivity by the bridgeheads instead of the tethers, which are brought together by the two Ugi-4CRs. As shown in Scheme 21, this method allows the assembly of hybrid steroidal cages with the incorporation of three bifunctional components. Thus, cholanic dicarboxylic acids **73** and **74** were macrocyclized with a paraformaldehyde-derived diimine and two different aryl diisocyanides to furnish steroidal cages **75** and **76** in good yields considering the structural complexity created in a single synthetic operation. It is worth mentioning that due to the rigid nature of the steroidal and aryl components, a flexible diamine was required to facilitate the macrobicycle ring closure. As before, *pseudo*-dilution conditions were employed by the simultaneous slow addition of the three bifunctional components.

## Conclusion

We have demonstrated that MCRs are powerful tools for the derivatization of steroids, including the formation of steroidal heterocycles and macrocycles and the conjugation to other biomolecular components. Various well-known MCRs such as the Ugi, Passerini, Biginelli and Petasis reactions have proven effective in the installation of skeletal diversity attached to the steroid ring system, while many other modern methods have also shown success using steroidal as one of their components. In addition, we showed that the synthesis of steroid-peptide and



**Scheme 20:** Synthesis of steroidal macrobicycles (cages) by multiple multicomponent macrocyclizations based on the Ugi-4CR [73,75].



**Scheme 21:** One-pot synthesis of steroidal cages by double Ugi-4CR-based macrocyclizations [76].

steroid-carbohydrate conjugates is feasible by means of both solution and solid-phase multicomponent methodologies, which opens a venue of possibilities for the production of more complex biomolecular conjugates. Nonetheless, there are still many MCRs that have not been implemented using steroidal substrates, therefore, there is still much to be done for an effective exploitation of the MCR potential in the rapid diversification of steroidal products for screening of their pharmaceutical and biological properties. We expect this review serves as inspiration for the MCR community to further explore the scope of steroids in the development of new reactions and methods.

## ORCID® IDs

Javier A. Ramírez - <https://orcid.org/0000-0002-2013-540X>

Daniel G. Rivera - <https://orcid.org/0000-0002-5538-1555>

## References

- Zhu, J.; Wang, Q.; Wang, M.-X., Eds. *Multicomponent Reactions in Organic Synthesis*; Wiley-VCH Verlag GmbH: Weinheim, Germany, 2014. doi:10.1002/9783527678174
- Brauch, S.; van Berkel, S. S.; Westermann, B. *Chem. Soc. Rev.* **2013**, *42*, 4948–4962. doi:10.1039/c3cs35505e
- Ruijter, E.; Scheffelaar, R.; Orru, R. V. A. *Angew. Chem., Int. Ed.* **2011**, *50*, 6234–6246. doi:10.1002/anie.201006515
- Reguera, L.; Méndez, Y.; Humpierre, A. R.; Valdés, O.; Rivera, D. G. *Acc. Chem. Res.* **2018**, *51*, 1475–1486. doi:10.1021/acs.accounts.8b00126
- White, C. J.; Yudin, A. K. *Nat. Chem.* **2011**, *3*, 509–524. doi:10.1038/nchem.1062
- Wessjohann, L. A.; Rhoden, C. R.; Rivera, D. G.; Vercillo, O. E. Cyclic Peptidomimetics and Pseudopeptides from Multicomponent Reactions. In *Synthesis of Heterocycles via Multicomponent Reactions*; Orru, R. V. A.; Ruijter, E., Eds.; Springer: Berlin, 2010; pp 199–226. doi:10.1007/7081\_2009\_25
- Méndez, Y.; Chang, J.; Humpierre, A. R.; Zanuy, A.; Garrido, R.; Vasco, A. V.; Pedroso, J.; Santana, D.; Rodríguez, L. M.; García-Rivera, D.; Valdés, Y.; Vérez-Bencomo, V.; Rivera, D. G. *Chem. Sci.* **2018**, *9*, 2581–2588. doi:10.1039/c7sc05467j
- Morejón, M. C.; Laub, A.; Kaluderović, G. N.; Puentes, A. R.; Hmedat, A. N.; Otero-González, A. J.; Rivera, D. G.; Wessjohann, L. A. *Org. Biomol. Chem.* **2017**, *15*, 3628–3637. doi:10.1039/c7ob00459a
- Pérez-Labrada, K.; Brouard, I.; Méndez, I.; Rivera, D. G. *J. Org. Chem.* **2012**, *77*, 4660–4670. doi:10.1021/jo300462m
- Khan, M. M.; Yousuf, R.; Khan, S.; Shafiqullah, S. *RSC Adv.* **2015**, *5*, 57883–57905. doi:10.1039/c5ra08059b
- Rivera, D. G.; León, F.; Coll, F.; Davison, G. P. *Steroids* **2006**, *71*, 1–11. doi:10.1016/j.steroids.2005.02.024
- Wessjohann, L. A.; Andrade, C. K. Z.; Vercillo, O. E.; Rivera, D. G. In *Targets Heterocycle Systems: Chemistry and Properties*; Attanasi, O. A.; Spinelli, D., Eds.; Siceta Chimica Italiana: Roma, 2006; Vol. 10, pp 24–53.
- Wessjohann, L. A.; Rivera, D. G.; Vercillo, O. E. *Chem. Rev.* **2009**, *109*, 796–814. doi:10.1021/cr8003407
- Dömling, A.; Kehagia, K.; Ugi, I. *Tetrahedron* **1995**, *51*, 9519–9522. doi:10.1016/0040-4020(95)00541-f
- Eckert, H.; Ugi, I. *The Role of Isocyanides in the Synthesis of  $\beta$ -Lactam Antibiotics and Related Compounds*; Stereoselective Synthesis, Vol. 12; Elsevier: Amsterdam, Netherlands, 1993; pp 113–143. doi:10.1016/b978-0-444-89366-6.70010-1
- Bruttomesso, A. C.; Eiras, J.; Ramírez, J. A.; Galagovsky, L. R. *Tetrahedron Lett.* **2009**, *50*, 4022–4024. doi:10.1016/j.tetlet.2009.03.219
- Marcaccini, S.; Pepino, R.; Pozo, M. C. *Tetrahedron Lett.* **2001**, *42*, 2727–2728. doi:10.1016/s0040-4039(01)00232-5
- Dar, A. M.; Shamsuzzaman; Gatoo, M. A. *Steroids* **2015**, *104*, 163–175. doi:10.1016/j.steroids.2015.09.010
- Rivera, D. G.; Pando, O.; Coll, F. *Tetrahedron* **2006**, *62*, 8327–8334. doi:10.1016/j.tet.2006.06.050
- Echemendía, R.; Concepción, O.; Morales, F. E.; Paixão, M. W.; Rivera, D. G. *Tetrahedron* **2014**, *70*, 3297–3305. doi:10.1016/j.tet.2013.10.032
- Rivera, D. G.; Concepción, O.; Pérez-Labrada, K.; Coll, F. *Tetrahedron* **2008**, *64*, 5298–5305. doi:10.1016/j.tet.2008.03.023
- Alonso, F.; Cirigliano, A. M.; Cabrera, G. M.; Ramírez, J. A. *Steroids* **2010**, *75*, 659–664. doi:10.1016/j.steroids.2010.04.002
- Dávola, M. E.; Alonso, F.; Cabrera, G. M.; Ramírez, J. A.; Barquero, A. A. *Biochem. Biophys. Res. Commun.* **2012**, *427*, 107–112. doi:10.1016/j.bbrc.2012.09.019
- Alonso, F.; Cirigliano, A. M.; Dávola, M. E.; Cabrera, G. M.; García Liñares, G. E.; Labriola, C.; Barquero, A. A.; Ramírez, J. A. *Steroids* **2014**, *84*, 1–6. doi:10.1016/j.steroids.2014.03.002
- Dávola, M. E.; Mazaira, G. I.; Galigniana, M. D.; Alché, L. E.; Ramírez, J. A.; Barquero, A. A. *Antiviral Res.* **2015**, *122*, 55–63. doi:10.1016/j.antiviral.2015.08.002
- Alonso, F.; Acebedo, S. L.; Bruttomesso, A. C.; Ramírez, J. A. *Steroids* **2008**, *73*, 1270–1276. doi:10.1016/j.steroids.2008.06.002
- Borah, P.; Borah, J. M.; Chowdhury, P. *Steroids* **2015**, *98*, 49–57. doi:10.1016/j.steroids.2015.02.012
- Wessjohann, L. A.; Voigt, B.; Rivera, D. G. *Angew. Chem., Int. Ed.* **2005**, *44*, 4785–4790. doi:10.1002/anie.200500019  
See for, the first report on the synthesis; application of steroidal isocyanides.
- Rivera, D. G.; León, F.; Concepción, O.; Morales, F. E.; Wessjohann, L. A. *Chem. – Eur. J.* **2013**, *19*, 6417–6428. doi:10.1002/chem.201201591
- Lesma, G.; Luraghi, A.; Rainoldi, G.; Mattiuzzo, E.; Bortolozzi, R.; Viola, G.; Silvani, A. *Synthesis* **2016**, *48*, 3907–3916. doi:10.1055/s-0035-1562497
- Echemendía, R.; da Silva, G. P.; Kawamura, M. Y.; de la Torre, A. F.; Corrêa, A. G.; Ferreira, M. A. B.; Rivera, D. G.; Paixão, M. W. *Chem. Commun.* **2019**, *55*, 286–289. doi:10.1039/c8cc06871b
- Echemendía, R.; de La Torre, A. F.; Monteiro, J. L.; Pila, M.; Corrêa, A. G.; Westermann, B.; Rivera, D. G.; Paixão, M. W. *Angew. Chem., Int. Ed.* **2015**, *54*, 7621–7625. doi:10.1002/anie.201412074
- Dumestre, P.; El Kaïm, L.; Grégoire, A. *Chem. Commun.* **1999**, *775*–776. doi:10.1039/a900987f
- Mayorquín-Torres, M. C.; Flores-Álamo, M.; Iglesias-Arteaga, M. A. *Tetrahedron Lett.* **2017**, *58*, 3500–3504. doi:10.1016/j.tetlet.2017.07.081
- Barluenga, J.; Mendoza, A.; Rodríguez, F.; Fañanás, F. J. *Angew. Chem., Int. Ed.* **2009**, *48*, 1644–1647. doi:10.1002/anie.200805519

36. Asif, M.; Ali, A.; Zafar, A.; Farhan, M.; Khanam, H.; Hadi, S. M.; Shamsuzzaman. *J. Photochem. Photobiol., B* **2017**, *166*, 104–115. doi:10.1016/j.jphotobiol.2016.11.010
37. Huang, B.; Zeng, L.; Shen, Y.; Cui, S. *Angew. Chem., Int. Ed.* **2017**, *56*, 4565–4568. doi:10.1002/anie.201700840
38. Chen, R.; Liu, Y.; Cui, S. *Chem. Commun.* **2018**, *54*, 11753–11756. doi:10.1039/c8cc07328g
39. Wang, C.; Xu, H.; Xie, Z.; Wang, X.; Zhang, Z.; Sun, Q. *Steroids* **2010**, *75*, 1033–1038. doi:10.1016/j.steroids.2010.06.007
40. Rivera, D. G.; Peseke, K.; Jomarrón, I.; Montero, A.; Molina, R.; Coll, F. *Molecules* **2003**, *8*, 444–452. doi:10.3390/80500444
41. Kappe, C. O. In *Multicomponent Reactions*; Zhu, J.; Bienaymé, H., Eds.; Wiley-VCH Verlag GmbH & Co. KGaA: Weinheim, 2005; pp 95–120.  
See for a review.
42. Bajji, Á.; Kiss, T.; Wöfling, J.; Kovács, D.; Igaz, N.; Gopisetty, M. K.; Kiricsi, M.; Frank, É. *J. Steroid Biochem. Mol. Biol.* **2017**, *172*, 79–88. doi:10.1016/j.jsbmb.2017.06.001
43. Dutta, M.; Gogoi, J.; Shekarrao, K.; Goswami, J.; Gogoi, S.; Boruah, R. *Synthesis* **2012**, *44*, 2614–2622. doi:10.1055/s-0032-1316564
44. Mohamed, N. R.; Abdelhalim, M. M.; Khadrawy, Y. A.; Elmegeed, G. A.; Abdel-Salam, O. M. E. *Steroids* **2012**, *77*, 1469–1476. doi:10.1016/j.steroids.2012.09.001
45. Abd Elhalim, M. M.; Ismail, N. S. M.; M Yahya, S. M.; Omar, Y. Y.; Abd Rabou, A. A.; Lasheen, D. S.; Zawrah, M. F.; Elmegeed, G. A. *Asian Pac. J. Cancer Prev.* **2017**, *18*, 1937–1946.
46. Barthakur, M. G.; Gogoi, S.; Dutta, M.; Boruah, R. C. *Steroids* **2009**, *74*, 730–734. doi:10.1016/j.steroids.2009.03.006
47. Saikia, P.; Gogoi, S.; Gogoi, S.; Boruah, R. C. *Steroids* **2014**, *88*, 1–6. doi:10.1016/j.steroids.2014.06.015
48. Saikia, P.; Kaishap, P. P.; Prakash, R.; Shekarrao, K.; Gogoi, S.; Boruah, R. C. *Tetrahedron Lett.* **2014**, *55*, 3896–3900. doi:10.1016/j.tetlet.2014.05.021
49. Dutta, M.; Saikia, P.; Gogoi, S.; Boruah, R. C. *Steroids* **2013**, *78*, 387–395. doi:10.1016/j.steroids.2013.01.006
50. Schulze, M.; Scott, D. E.; Scherer, A.; Hampel, F.; Hamilton, R. J.; Gray, M. R.; Tykwinski, R. R.; Stryker, J. M. *Org. Lett.* **2015**, *17*, 5930–5933. doi:10.1021/acs.orglett.5b03193
51. Schulze, M.; Scherer, A.; Hampel, F.; Stryker, J. M.; Tykwinski, R. R. *Chem. – Eur. J.* **2016**, *22*, 3378–3386. doi:10.1002/chem.201504683
52. Wang, W.; Zhang, M.-M.; Wang, X.-S. *J. Heterocycl. Chem.* **2014**, *51*, 175–178. doi:10.1002/jhet.1606
53. Tietze, L. F. *J. Heterocycl. Chem.* **1990**, *27*, 47–69. doi:10.1002/jhet.5570270105
54. Tietze, L. F.; Beifuss, U.; Lökös, M.; Rischer, M.; Göhr, A.; Scheldrick, G. M. *Angew. Chem., Int. Ed. Engl.* **1990**, *29*, 527–529. doi:10.1002/anie.199005271
55. Tietze, L. F.; Rackelmann, N. In *Multicomponent Reactions*; Zhu, J.; Bienaymé, H., Eds.; Wiley-VCH Verlag GmbH & Co. KGaA: Weinheim, 2005; pp 121–168.
56. Tietze, L. F.; Brasche, G.; Gericke, K. M. *Domino Reactions in Organic Synthesis*; Wiley-VCH Verlag GmbH & Co. KGaA: Weinheim, Germany, 2006. doi:10.1002/9783527609925
57. Hostettmann, K.; Marston, A. *Saponins*; Cambridge University Press: Cambridge, UK, 1995. doi:10.1017/cbo9780511565113
58. Pérez-Labrada, K.; Brouard, I.; Morera, C.; Estévez, F.; Bermejo, J.; Rivera, D. G. *Tetrahedron* **2011**, *67*, 7713–7727. doi:10.1016/j.tet.2011.08.003
59. De Muynck, H.; Madder, A.; Farcy, N.; De Clercq, P. J.; Pérez-Payán, M. N.; Öhberg, L. M.; Davis, A. P. *Angew. Chem., Int. Ed.* **2000**, *39*, 145–148. doi:10.1002/(sici)1521-3773(20000103)39:1<145::aid-anie145>3.0.co;2-j
60. Ding, B.; Taotofa, U.; Orsak, T.; Chadwell, M.; Savage, P. B. *Org. Lett.* **2004**, *6*, 3433–3436. doi:10.1021/ol048845t
61. Bodé, C. A.; Bechet, T.; Prodhomme, E.; Gheysen, K.; Gregoir, P.; Martins, J. C.; Muller, C. P.; Madder, A. *Org. Biomol. Chem.* **2009**, *7*, 3391–3399. doi:10.1039/b907395g
62. Rivera, D. G.; Pérez-Labrada, K.; Lambert, L.; Dörner, S.; Westermann, B.; Wessjohann, L. A. *Carbohydr. Res.* **2012**, *359*, 102–110. doi:10.1016/j.carres.2012.05.003
63. Rivera, D. G.; Vasco, A. V.; Echemendía, R.; Concepción, O.; Pérez, C. S.; Gavín, J. A.; Wessjohann, L. A. *Chem. – Eur. J.* **2014**, *20*, 13150–13161. doi:10.1002/chem.201403773
64. Morales, F. E.; Garay, H. E.; Muñoz, D. F.; Augusto, Y. E.; Otero-González, A. J.; Reyes Acosta, O.; Rivera, D. G. *Org. Lett.* **2015**, *17*, 2728–2731. doi:10.1021/acs.orglett.5b01147
65. Pérez-Labrada, K.; Méndez, Y.; Brouard, I.; Rivera, D. G. *ACS Comb. Sci.* **2013**, *15*, 320–330. doi:10.1021/co400028e
66. Vasco, A. V.; Méndez, Y.; Porzel, A.; Balbach, J.; Wessjohann, L. A.; Rivera, D. G. *Bioconjugate Chem.* **2019**, *30*, 253–259. doi:10.1021/acs.bioconjchem.8b00906
67. Morejón, M. C.; Laub, A.; Westermann, B.; Rivera, D. G.; Wessjohann, L. A. *Org. Lett.* **2016**, *18*, 4096–4099. doi:10.1021/acs.orglett.6b02001
68. Ricardo, M. G.; Llanes, D.; Wessjohann, L. A.; Rivera, D. G. *Angew. Chem., Int. Ed.* **2019**, *58*, 2700–2704. doi:10.1002/anie.201812620
69. Petasis, N. A.; Akritopoulou, I. *Tetrahedron Lett.* **1993**, *34*, 583–586. doi:10.1016/s0040-4039(00)61625-8
70. Wessjohann, L. A.; Rivera, D. G.; Coll, F. *J. Org. Chem.* **2006**, *71*, 7521–7526. doi:10.1021/jo0608570
71. Rivera, D. G.; Wessjohann, L. A. *Molecules* **2007**, *12*, 1890–1899. doi:10.3390/12081890
72. Rivera, D. G.; Pando, O.; Bosch, R.; Wessjohann, L. A. *J. Org. Chem.* **2008**, *73*, 6229–6238. doi:10.1021/jo800708m
73. Rivera, D. G.; Wessjohann, L. A. *J. Am. Chem. Soc.* **2006**, *128*, 7122–7123. doi:10.1021/ja060720r
74. Rivera, D. G.; Vercillo, O. E.; Wessjohann, L. A. *Org. Biomol. Chem.* **2008**, *6*, 1787–1795. doi:10.1039/b715393g
75. Rivera, D. G.; Wessjohann, L. A. *J. Am. Chem. Soc.* **2009**, *131*, 3721–3732. doi:10.1021/ja809005k
76. Wessjohann, L. A.; Kreye, O.; Rivera, D. G. *Angew. Chem., Int. Ed.* **2017**, *56*, 3501–3505. doi:10.1002/anie.201610801

## License and Terms

This is an Open Access article under the terms of the Creative Commons Attribution License (<http://creativecommons.org/licenses/by/4.0>). Please note that the reuse, redistribution and reproduction in particular requires that the authors and source are credited.

The license is subject to the *Beilstein Journal of Organic Chemistry* terms and conditions: (<https://www.beilstein-journals.org/bjoc>)

The definitive version of this article is the electronic one which can be found at:  
[doi:10.3762/bjoc.15.121](https://doi.org/10.3762/bjoc.15.121)



## Doebner-type pyrazolopyridine carboxylic acids in an Ugi four-component reaction

Maryna V. Murlykina<sup>1,2,3</sup>, Oleksandr V. Kolomiets<sup>1,2</sup>, Maryna M. Kornet<sup>4</sup>, Yana I. Sakhno<sup>1</sup>, Sergey M. Desenko<sup>1,2</sup>, Victoriya V. Dyakonenko<sup>1</sup>, Svetlana V. Shishkina<sup>1,2</sup>, Oleksandr A. Brazhko<sup>4</sup>, Vladimir I. Musatov<sup>1</sup>, Alexander V. Tsygankov<sup>5</sup>, Erik V. Van der Eycken<sup>3,6</sup> and Valentyn A. Chebanov<sup>\*1,2,3</sup>

### Full Research Paper

[Open Access](#)**Address:**

<sup>1</sup>Division of Chemistry of Functional Materials, State Scientific Institution "Institute for Single Crystals" of National Academy of Sciences of Ukraine, Nauky Ave., 60, 61072, Kharkiv, Ukraine, <sup>2</sup>Faculty of Chemistry, V. N. Karazin Kharkiv National University, Svobody sq., 4, 61077, Kharkiv, Ukraine, <sup>3</sup>Laboratory for Organic & Microwave-Assisted Chemistry (LOMAC), KU Leuven, Celestijnenlaan 200F, B-3001, Leuven, Belgium, <sup>4</sup>Laboratory of Biotechnology of Physiologically Active Substances, Zaporizhzhia National University, Zhukovsky str., 66, Zaporizhzhya, Ukraine, 69600, <sup>5</sup>National Technical University "Kharkiv Polytechnic Institute", Kyrpychova str., 2, 61002, Kharkiv, Ukraine and <sup>6</sup>Peoples' Friendship University of Russia, Miklukho-Maklya str., 6, 117198, Moscow, Russia

**Email:**

Valentyn A. Chebanov\* - chebanov@isc.kh.ua

\* Corresponding author

**Keywords:**

antibacterial activity; Doebner reaction; pyrazolo[3,4-*b*]pyridine carboxylic acids; Ugi reaction

*Beilstein J. Org. Chem.* **2019**, *15*, 1281–1288.

doi:10.3762/bjoc.15.126

Received: 03 March 2019

Accepted: 17 May 2019

Published: 12 June 2019

This article is part of the thematic issue "Multicomponent reactions III".

Guest Editor: T. J. J. Müller

© 2019 Murlykina et al.; licensee Beilstein-Institut.

License and terms: see end of document.

### Abstract

Substituted 1*H*-pyrazolo[3,4-*b*]pyridine-4- and 1*H*-pyrazolo[3,4-*b*]pyridine-6-carboxamides have been synthesized through a Doebner–Ugi multicomponent reaction sequence in a convergent and versatile manner using diversity generation strategies: combination of two multicomponent reactions and conditions-based divergence strategy. The target products contain as pharmacophores pyrazolopyridine and peptidomimetic moieties with four points of diversity introduced from readily available starting materials including scaffold diversity. A small focused compound library of 23 Ugi products was created and screened for antibacterial activity.

### Introduction

Modern medicinal chemistry is faced with the task of quick and effective screening a variety of organic molecules in order to identify new active pharmaceutical ingredients among them.

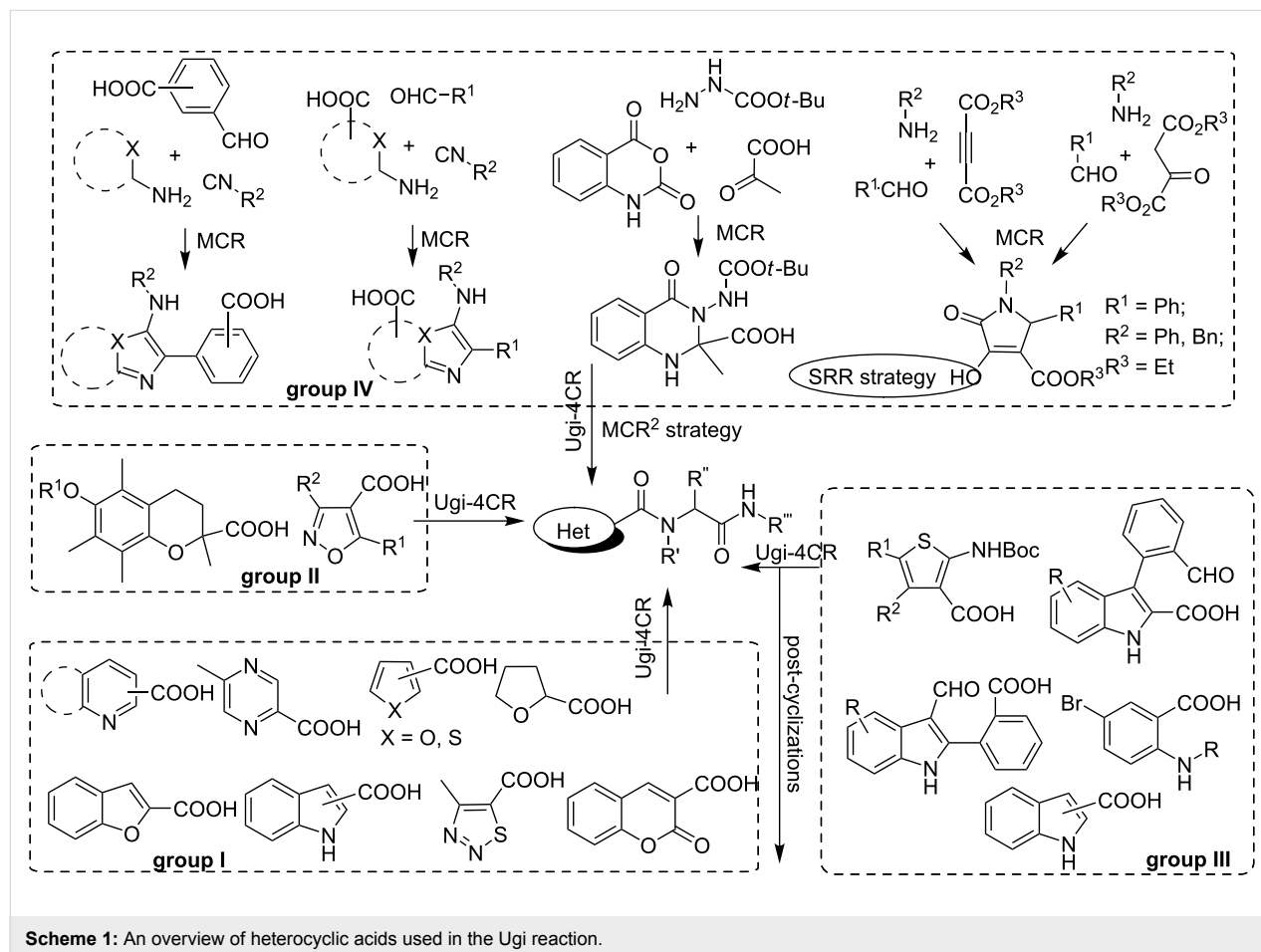
Therefore, in turn, organic chemistry has to solve an equally important task of the rapid generating focused libraries of drug-like compounds characterized by several important features,

e.g., molecular complexity and diversity at different levels, high variability and easy accessibility from relatively simple reagents. These challenges can be overcome by using multi-component reactions (MCRs) but also other strategies can be applied in addition to MCRs for generating diversity, e.g., build/couple/pair- (BCP), single reactant replacement- (SRR), modular reaction sequences- (MRS), conditions-based divergence- (CBD) and combination of multicomponent reactions (MCR<sup>2</sup>) strategies (for more details and examples see [1-3] and Scheme 1). A synergetic application of several diversity-oriented synthesis (DOS) instruments allows an effective decoration of the privileged scaffolds for creating collections of unique, highly potent bioactive compounds [4,5].

The pyrazolopyridine scaffold can be regarded as a privileged motif as it exhibits various biological actions: antiproliferative [6-9], antimicrobial [10,11], anxiolytic [12], analgesic [13], hypnotic [13], antiviral [13], anti-HIV [13] activities, etc. Soural et al. [14] explored different data and showed the relevance of compounds composed of two or more heterocyclic rings for drug discovery. The target products containing a heterocyclic core bound to a peptide-like chain also showed a

broad spectrum of biological activity:  $\beta$ -secretase (BACE1) inhibitory activity [15]; inducing apoptosis in colorectal cancer cells [16]; antimalarial activity against a chloroquine (CQ) non-resistant *Plasmodium falciparum* 3D7 strain [17]; antagonists of p53-Mdm2 interaction [18]; antiproliferative activity in the human solid tumor cell lines A549 (lung), HBL-100 (breast), HeLa (cervix), SW1573 (lung), T-47D (breast), and WiDr (colon) [19]; cyclophilin A inhibitory activity for the treatment of hepatitis C virus infections [20], etc.

Among the variety of heterocyclic acids used in Ugi-4CR [15-19,21-42] only a few of them in addition to bearing a simple pharmacophore core (group I, Scheme 1) are also characterized by the complexity and diversity of the skeleton itself gained through multi-step transformations (group II) [18,19,34-36] or allow for generating additional diversity through post-cyclization reactions (group III) [18,35-42]. Meanwhile the complexity of the acid skeleton can be achieved by MCR. Several publications illustrated this principle: synthesis of heterocyclic acids [26,43] or enols [44] in a first multicomponent step, followed by subjecting them to a subsequent Ugi process, thus, applying the MCR<sup>2</sup> approach (group IV, Scheme 1).



Actually, there was no example for the combined application of Doebner and Ugi-type MCRs although the former condensation easily affords the azoloazine pharmacophore that is able to participate as an acid component in the latter reaction. It should be noted, that Cowen et al. [6] reported *N*-substituted-1*H*-pyrazolo[3,4-*b*]pyridine-4-carboxamides being SMYD2 inhibitors (an oncogenic methyltransferase that represses the functional activity of the tumor suppressor proteins p53 and RB); the similar structures can be obtained using the methodology of sequential Doebner- and Ugi-type MCRs.

In the present work we combined several diversity-oriented synthetic (DOS) approaches. First, by using CBD and MCR strategies in a Doebner-type reaction we synthesized pyrazolopyridine carboxylic acids which were subsequently applied in the Ugi reaction, thus, combining two multicomponent procedures.

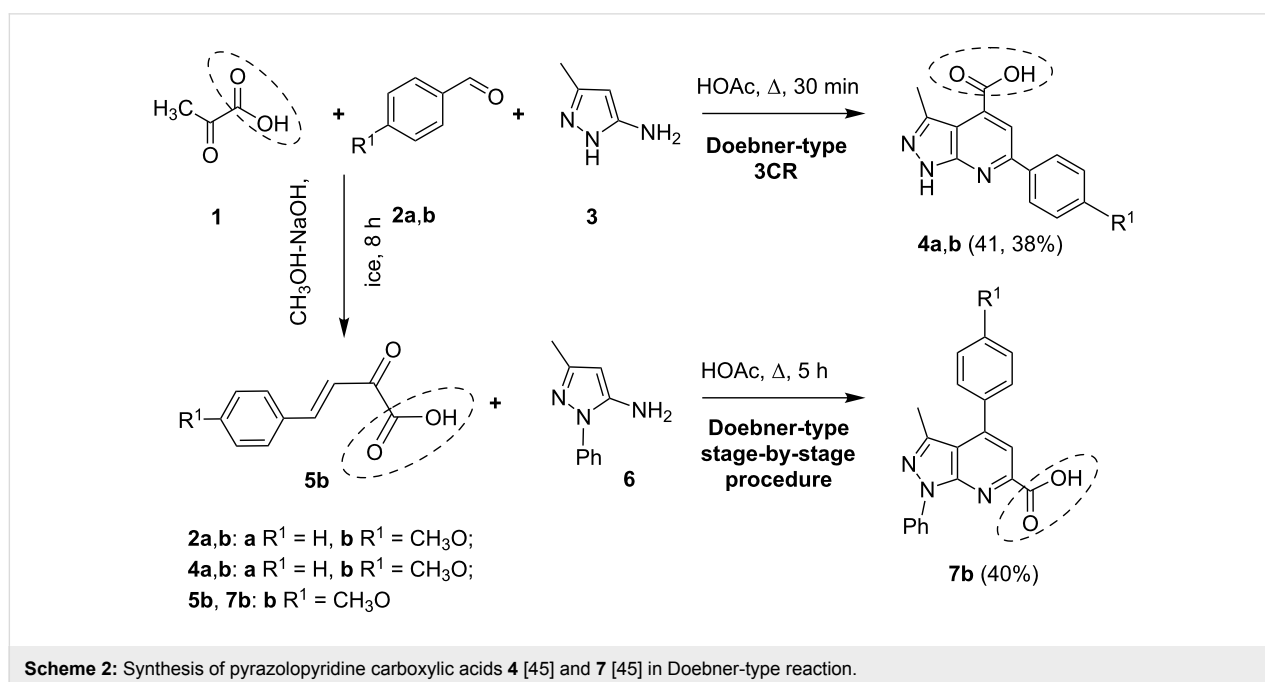
## Results and Discussion

As mentioned above, the diversification of the privileged scaffold using different DOS strategies allowed to significantly increase the diversity of the final products. In our study pyrazolo[3,4-*b*]pyridine scaffold was chosen as a privileged one and based on this, we combined two MCRs: the previously well-studied three-component Doebner-type condensation of aminopyrazoles, aldehydes and pyruvic acid [45,46] with the isocyanide-based four-component Ugi reaction.

As we have shown before [47,48] the application of the CBD strategy to multicomponent Doebner-type condensations involving aminoazoles allowed the synthesis of several chemo-

types of structurally complex products from a limited number of relatively simple starting materials just by varying the reaction conditions (temperature, solvent–catalyst system, activation method, forced realization of one of the cascades of multicomponent treatment). We decided to use this strategy and to synthesize heteroaromatic carboxylic acids **4** and **7** starting from the same reactants but using a multicomponent and a sequential protocol. We chose these heterocyclic acids to be subjected to the further Ugi transformation based on their higher stability compared to other azoloazine carboxylic acids (e.g., tetrahydro-[49,50] and dihydroazoloazines that may undergo oxidation during the Ugi 4CR) and as they do not contain additional functional groups that may influence the subsequent Ugi reaction (e.g., hydroxy group in tetrahydro- [46,51], dihydro- [51] or aromatic derivatives [51]).

Two different reaction pathways were applied based on known synthetic procedures (Scheme 2): the three-component reaction between pyruvic acid (**1**), aromatic aldehydes **2a,b** and 5-amino-3-methylpyrazole (**3**) (HOAc, Δ, 30 min) [45] and a two-component condensation of the preliminary synthesized 4-(4-methoxyphenyl)-2-oxobut-3-enoic acid (**5b**) [52,53] with 5-amino-3-methyl-*N*-phenylpyrazole (**6**) (HOAc, Δ, 5 h). As a result, two different types of pyrazolo[3,4-*b*]pyridines containing the carboxylic group either at C4 position (compounds **4a,b**) or at the C6 position (compound **7b**) were synthesized (Scheme 2). We modified the earlier described methodology for the synthesis of pyrazolo[3,4-*b*]pyridine-6-carboxylic acid (**7b**) [45]: the solvent was changed from DMF to HOAc and the reaction time was increased from 30 min to 5 hours. Despite of



the longer reaction time the whole procedure became more efficient due to the easier work-up stage as well as due to avoiding the formation of impurities of the dihydropyrazolo[3,4-*b*]pyridines.

Thus, starting from the same set of reactants two different types of heterocyclic acids **4** and **7** containing two diversity points were obtained. Afterwards compounds **4a,b** were introduced into the Ugi four-component reaction to create 3 additional points of diversity. However, due to the low solubility of the pyrazolopyridine acids **4a,b** under the literature standard reaction conditions for the Ugi transformation (stirring in methanol at rt and similar procedures) the reaction did not take place. Under these conditions, the pyrazolopyridine carboxylic acids **4a,b** did not dissolve and remained unreacted even after prolonged stirring and heating. Consequently, the solvent was changed to DMF that allowed us to isolate the Ugi products **11** after long stirring (48–72 h) at rt. It must be noted, that in many cases the pyrazolopyridine acids **4a,b** did not fully dissolve in DMF at rt that resulted in considerably decreased yields.

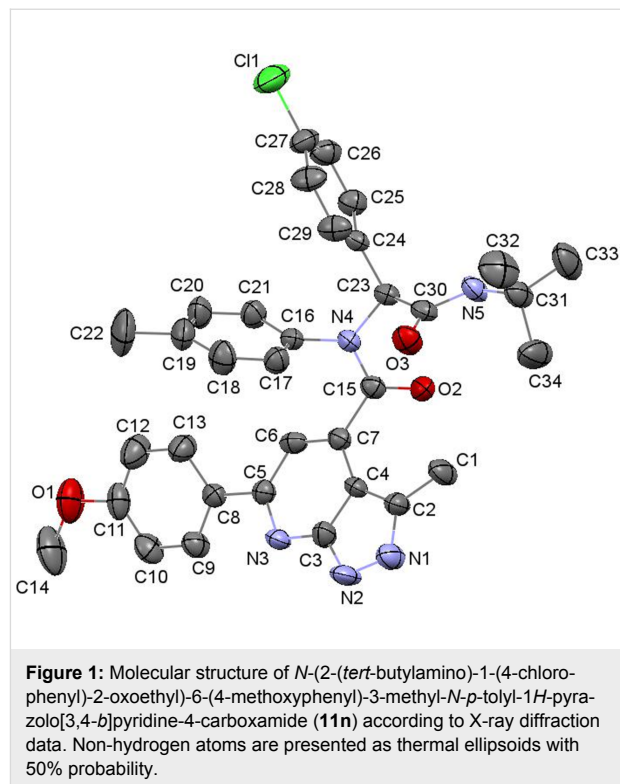
In an attempt to increase the yield of the products the reaction was repeated at different temperatures ranging from rt to 80 °C and it was found that heating at 70 °C afforded the best results. At this temperature not only the yields increased but also the reaction time could be reduced to 48 hours. When applying a solvent mixture of DMF and MeOH the yields further increased, with the best results obtained using a ratio of 1:2. We presume that methanol provides the optimal acidity to the reaction medium needed for successful protonation of the intermediate azomethine, formed between the aromatic aldehyde **8** and aniline **9**, to the corresponding iminium cation and its further transformation involving carboxylic acid **4** and isocyanide **10**.

As a result, we developed an efficient procedure for the synthesis of compounds **11a–q** through reaction of aromatic aldehydes **8a–d**, amines **9a–f**, *tert*-butylisocyanide (**10**) and heteroaromatic carboxylic acids **4a,b** in a 2:1 mixture of methanol and DMF at 70 °C. Following this procedure, a small library of seventeen Ugi products was obtained (Table 1).

Next, we applied pyrazolo[3,4-*b*]pyridine-6-carboxylic acid **7b** with another positional location of the substituents in comparison with compounds **4** in the Ugi reaction with the same reagents **8**, **9** and **10** using the optimized procedure (Table 1). This expanded the library of Ugi products by adding compounds **12a–f**.

The purity and structures of the obtained heterocyclic products were established by means of NMR spectroscopy, mass spectrometry, and elemental analysis. The final assignment of the

structures **11** and **12** was made by X-ray analysis for the structure **11n** (Figure 1).

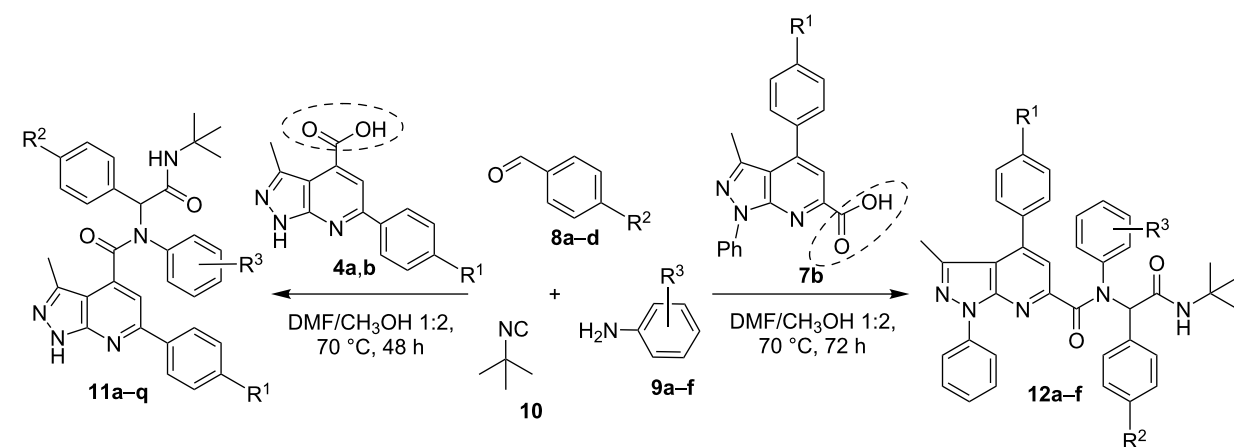


## Antibacterial activity

It is worth mentioning that the modification of the pyrazolo[3,4-*b*]pyridine scaffold through Ugi reaction allowed not only to introduce three additional diversity points but also to increase significantly the solubility of the products **11** and **12** compared to the starting acids **4** and **7**. Compounds **11** are soluble in MeOH, EtOH, *i*PrOH, acetone, EtOAc, CH<sub>3</sub>CN, DCM, CHCl<sub>3</sub> and compounds **12** are soluble in acetone, CH<sub>3</sub>CN, DCM, CHCl<sub>3</sub> and partially soluble when heated in EtOAc, MeOH, EtOH, showing the advantages of this protocol for investigating the activity of pyrazolo[3,4-*b*]pyridine moiety in biological experiments. Particularly, the evaluation of the antibacterial activity of the small library of new compounds **11** and **12** was carried out.

We next screened some selected compounds for their antibacterial activity (Table 2, Supporting Information File 1) against the reference bacterial strains *Bacillus subtilis* (strain 1211), *Staphylococcus aureus* (strain 2231) (gram-positive) and *Escherichia coli* (strain 1257), *Pseudomonas aeruginosa* (strain 1111) (gram-negative).

Generally, the compounds were found to be less active than nitroxoline being the reference substance. The results obtained

**Table 1:** Synthesis of compounds **11** and **12** by combination of Doebner and Ugi-type MCRs.

Entry	Starting materials					Products		
	Acid	R <sup>1</sup>	<b>8</b>	R <sup>2</sup>	<b>9</b>	R <sup>3</sup>	<b>11,12</b>	yield, %
1	<b>4a</b>	H	<b>8a</b>	H	<b>9a</b>	H	<b>11a</b>	39
2	<b>4a</b>	H	<b>8a</b>	H	<b>9b</b>	4-CH <sub>3</sub>	<b>11b</b>	40
3	<b>4a</b>	H	<b>8a</b>	H	<b>9c</b>	4-Br	<b>11c</b>	30
4	<b>4a</b>	H	<b>8a</b>	H	<b>9d</b>	2-CH <sub>3</sub> O	<b>11d</b>	28
5	<b>4a</b>	H	<b>8a</b>	H	<b>9e</b>	3-CH <sub>3</sub> O	<b>11e</b>	30
6	<b>4a</b>	H	<b>8a</b>	H	<b>9f</b>	4-CH <sub>3</sub> O	<b>11f</b>	42
7	<b>4b</b>	CH <sub>3</sub> O	<b>8a</b>	H	<b>9a</b>	H	<b>11g</b>	43
8	<b>4b</b>	CH <sub>3</sub> O	<b>8a</b>	H	<b>9b</b>	4-CH <sub>3</sub>	<b>11h</b>	53
9	<b>4b</b>	CH <sub>3</sub> O	<b>8a</b>	H	<b>9c</b>	4-Br	<b>11i</b>	37
10	<b>4b</b>	CH <sub>3</sub> O	<b>8a</b>	H	<b>9d</b>	2-CH <sub>3</sub> O	<b>11j</b>	37
11	<b>4b</b>	CH <sub>3</sub> O	<b>8a</b>	H	<b>9e</b>	3-CH <sub>3</sub> O	<b>11k</b>	35
12	<b>4b</b>	CH <sub>3</sub> O	<b>8a</b>	H	<b>9f</b>	4-CH <sub>3</sub> O	<b>11l</b>	42
13	<b>4b</b>	CH <sub>3</sub> O	<b>8b</b>	Cl	<b>9a</b>	H	<b>11m</b>	44
14	<b>4b</b>	CH <sub>3</sub> O	<b>8b</b>	Cl	<b>9b</b>	4-CH <sub>3</sub>	<b>11n</b>	49
15	<b>4b</b>	CH <sub>3</sub> O	<b>8b</b>	Cl	<b>9c</b>	4-Br	<b>11o</b>	34
16	<b>4b</b>	CH <sub>3</sub> O	<b>8b</b>	Cl	<b>9f</b>	4-CH <sub>3</sub> O	<b>11p</b>	37
17	<b>4b</b>	CH <sub>3</sub> O	<b>8c</b>	NO <sub>2</sub>	<b>9a</b>	H	<b>11q</b>	20
18	<b>7b</b>	CH <sub>3</sub> O	<b>8a</b>	H	<b>9a</b>	H	<b>12a</b>	50
19	<b>7b</b>	CH <sub>3</sub> O	<b>8a</b>	H	<b>9b</b>	4-CH <sub>3</sub>	<b>12b</b>	51
20	<b>7b</b>	CH <sub>3</sub> O	<b>8b</b>	Cl	<b>9a</b>	H	<b>12c</b>	34
21	<b>7b</b>	CH <sub>3</sub> O	<b>8b</b>	Cl	<b>9b</b>	4-CH <sub>3</sub>	<b>12d</b>	36
22	<b>7b</b>	CH <sub>3</sub> O	<b>8d</b>	CH <sub>3</sub> O	<b>9a</b>	H	<b>12e</b>	46
23	<b>7b</b>	CH <sub>3</sub> O	<b>8d</b>	CH <sub>3</sub> O	<b>9b</b>	4-CH <sub>3</sub>	<b>12f</b>	25

indicate that some substances inhibited the growth of the test microorganisms demonstrating weak antimicrobial effect (Table 2). The growth of gram-positive bacteria (strains of *S. aureus* and *B. subtilis*) was inhibited in a more effective way. Particularly, compound **11b** inhibited the growth of *B. subtilis* at a concentration of 125 mg/L. A bacteriostatic activity against *S. aureus* was observed only at the higher concentrations of 250 and 500 mg/L. The same situation was found for the tested *E.*

*coli* strain. The gram-negative bacterium *P. aeruginosa* showed resistance to all compounds tested in the given concentration range. The observed low level of antibacterial activity of the synthesized heterocycles is a good prerequisite for screening them for other types of activity, e.g., anticancer, antidiabetic, etc., because in these cases a negative influence on the microflora of the organism would be decreased [54].

**Table 2:** Antibacterial activity results.

Entry	Compound	MIC <sup>a</sup> /MBC <sup>b</sup> , mg/L	Strains of test cultures			
			<i>Escherichia coli</i>	<i>Pseudomonas aeruginosa</i>	<i>Staphylococcus aureus</i>	<i>Bacillus subtilis</i>
1	<b>11a</b>	MIC	250	– <sup>c</sup>	250	250
		MBC	–	–	–	–
2	<b>11b</b>	MIC	500	–	500	125
		MBC	–	–	–	–
3	<b>11f</b>	MIC	–	–	–	–
		MBC	–	–	–	–
4	<b>11g</b>	MIC	250	–	–	250
		MBC	–	–	–	–
5	<b>11l</b>	MIC	–	–	–	–
		MBC	–	–	–	–
6	<b>11m</b>	MIC	500	–	250	250
		MBC	–	–	–	–
7	<b>nitroloxoline</b>	MIC	15.6	62.5	31.25	1.9
		MBC	15.6	62.5	31.25	1.9

<sup>a</sup>MIC – minimum inhibitory concentration; <sup>b</sup>MBC – minimum bactericidal concentration; <sup>c</sup>the substance at concentration ≤ 500 mg/L does not inhibit culture growth.

## Conclusion

In summary, two multicomponent reactions of Doebner and Ugi-type were combined in a convergent and versatile manner giving substituted 1*H*-pyrazolo[3,4-*b*]pyridine-4- and 1*H*-pyrazolo[3,4-*b*]pyridine-6-carboxamides. The use of a conditions-based divergence strategy allowed introducing the scaffold diversity and obtaining two types of structures with different orientation of substituents (containing a carboxylic group either at C4 or C6 position of the pyrazolopyridine core). The optimal methodology for the synthesis of target products was elaborated (mixture of methanol and DMF (2:1) and heating to 70 °C) and a small focused library of 23 Ugi products was created. The target compounds containing two pharmacophore pyrazolopyridine and peptidomimetic moieties were screened for their antibacterial activity and demonstrated weak antibacterial effect.

## Supporting Information

### Supporting Information File 1

Experimental and analytical data.

[<https://www.beilstein-journals.org/bjoc/content/supplementary/1860-5397-15-126-S1.pdf>]

### Supporting Information File 2

NMR spectra.

[<https://www.beilstein-journals.org/bjoc/content/supplementary/1860-5397-15-126-S2.pdf>]

## Acknowledgements

V. Chebanov was supported by a scholarship of KU Leuven (SF/14/006). M. Murlykina was supported by an Erasmus Mundus scholarship and by the Grant of National Academy of Sciences of Ukraine for young scientists' research laboratories and groups. The authors also thank the National Academy of Sciences of Ukraine for financial support in the frame of the projects "Creation of modern bases for obtaining and analyzing substances and components of materials for pharmaceutical purposes" (0119U100727) and "Investigation of structural features of nitrogen containing heterocycles with potential biological activity" (0119U100716). We thank Dr. E. Muravyouva for measuring the part of LC–MS spectra.

## ORCID® IDs

Maryna V. Murlykina - <https://orcid.org/0000-0002-0019-5237>

Maryna M. Kornet - <https://orcid.org/0000-0002-9251-5700>

Sergey M. Desenko - <https://orcid.org/0000-0001-8914-3232>

Alexander V. Tsygankov - <https://orcid.org/0000-0001-5298-8450>

Valentyn A. Chebanov - <https://orcid.org/0000-0001-7564-778X>

## References

- Ruijter, E.; Scheffelaar, R.; Orru, R. V. A. *Angew. Chem., Int. Ed.* **2011**, *50*, 6234–6246. doi:10.1002/anie.201006515
- Dömling, A.; Ugi, I. *Angew. Chem., Int. Ed. Engl.* **1993**, *32*, 563–564. doi:10.1002/anie.199305631
- Elders, N.; van der Born, D.; Hendrickx, L. J. D.; Timmer, B. J. J.; Krause, A.; Janssen, E.; de Kanter, F. J. J.; Ruijter, E.; Orru, R. V. A. *Angew. Chem., Int. Ed.* **2009**, *48*, 5856–5859. doi:10.1002/anie.200902683

4. Welsch, M. E.; Snyder, S. A.; Stockwell, B. R. *Curr. Opin. Chem. Biol.* **2010**, *14*, 347–361. doi:10.1016/j.cbpa.2010.02.018
5. Marcaurelle, L. A.; Foley, M. A. *Curr. Opin. Chem. Biol.* **2010**, *14*, 285–288. doi:10.1016/j.cbpa.2010.05.001
6. Cowen, S. D.; Russell, D.; Dakin, L. A.; Chen, H.; Larsen, N. A.; Godin, R.; Throner, S.; Zheng, X.; Molina, A.; Wu, J.; Cheung, T.; Howard, T.; Garcia-Arenas, R.; Keen, N.; Pendleton, C. S.; Pietenpol, J. A.; Ferguson, A. D. *J. Med. Chem.* **2016**, *59*, 11079–11097. doi:10.1021/acs.jmedchem.6b01303
7. Giannouli, V.; Lougiakis, N.; Kostakis, I. K.; Pouli, N.; Marakos, P.; Skaltsounis, A.-L.; Nam, S.; Jove, R.; Horne, D.; Tenta, R.; Pratsinis, H.; Kletsas, D. *Bioorg. Med. Chem. Lett.* **2016**, *26*, 5229–5233. doi:10.1016/j.bmcl.2016.09.056
8. Wenglowsky, S. *Expert Opin. Ther. Pat.* **2013**, *23*, 281–298. doi:10.1517/13543776.2013.749861
9. Ahmed, O. M.; Mohamed, M. A.; Ahmed, R. R.; Ahmed, S. A. *Eur. J. Med. Chem.* **2009**, *44*, 3519–3523. doi:10.1016/j.ejmech.2009.03.042
10. Abdel-Mohsen, S. A.; El-Emary, T. I. *Pharma Chem.* **2018**, *10*, 44–51.
11. Foks, H.; Pancechowska-Ksepko, D.; Kędzia, A.; Zwolska, Z.; Janowiec, M.; Augustynowicz-Kopeć, E. *Farmaco* **2005**, *60*, 513–517. doi:10.1016/j.farmac.2005.05.002
12. Patel, J. B.; Malick, J. B.; Salama, A. I.; Goldberg, M. E. *Pharmacol., Biochem. Behav.* **1985**, *23*, 675–680. doi:10.1016/0091-3057(85)90436-8
13. Dodiya, D. K.; Trivedi, A. R.; Kataria, V. P.; Shah, V. H. *Curr. Org. Chem.* **2012**, *16*, 400–417. doi:10.2174/138527212799499912
14. Soural, M.; Bouillon, I.; Krchnák, V. *J. Comb. Chem.* **2008**, *10*, 923–933. doi:10.1021/cc8001074
15. Edraki, N.; Firuzi, O.; Fatahi, Y.; Mahdavi, M.; Asadi, M.; Emami, S.; Divsalar, K.; Miri, R.; Iraj, A.; Khoshneviszadeh, M.; Firoozpour, L.; Shafiee, A.; Foroumadi, A. *Arch. Pharm. (Weinheim, Ger.)* **2015**, *348*, 330–337. doi:10.1002/ardp.201400322
16. He, L.-J.; Yang, D.-L.; Li, S.-Q.; Zhang, Y.-J.; Tang, Y.; Lei, J.; Frett, B.; Lin, H.-k.; Li, H.-y.; Chen, Z.-Z.; Xu, Z.-G. *Bioorg. Med. Chem.* **2018**, *26*, 3899–3908. doi:10.1016/j.bmc.2018.06.010
17. Avilés, E.; Prudhomme, J.; Le Roch, K. G.; Franzblau, S. G.; Chandrasena, K.; Mayer, A. M. S.; Rodríguez, A. D. *Bioorg. Med. Chem. Lett.* **2015**, *25*, 5339–5343. doi:10.1016/j.bmcl.2015.09.033
18. Huang, Y.; Wolf, S.; Bista, M.; Meireles, L.; Camacho, C.; Holak, T. A.; Dömling, A. *Chem. Biol. Drug Des.* **2010**, *76*, 116–129. doi:10.1111/j.1747-0285.2010.00989.x
19. Ingold, M.; Dapuetto, R.; Victoria, S.; Galliusi, G.; Batthyány, C.; Bollati-Fogolín, M.; Tejedor, D.; García-Tellado, F.; Padrón, J. M.; Porcal, W.; López, G. V. *Eur. J. Med. Chem.* **2018**, *143*, 1888–1902. doi:10.1016/j.ejmech.2017.11.003
20. Yang, S.; Jyothi, K. R.; Lim, S.; Choi, T. G.; Kim, J.-H.; Akter, S.; Jang, M.; Ahn, H.-J.; Kim, H.-Y.; Windisch, M. P.; Khadka, D. B.; Zhao, C.; Jin, Y.; Kang, I.; Ha, J.; Oh, B.-C.; Kim, M.; Kim, S. S.; Cho, W.-J. *J. Med. Chem.* **2015**, *58*, 9546–9561. doi:10.1021/acs.jmedchem.5b01064
21. Azuaje, J.; El Maatougui, A.; García-Mera, X.; Sotelo, E. *ACS Comb. Sci.* **2014**, *16*, 403–411. doi:10.1021/co500036n
22. Che, C.; Li, S.; Yu, Z.; Li, F.; Xin, S.; Zhou, L.; Lin, S.; Yang, Z. *ACS Comb. Sci.* **2013**, *15*, 202–207. doi:10.1021/co400001h
23. Ghandi, M.; Zarezadeh, N.; Abbasi, A. *Org. Biomol. Chem.* **2015**, *13*, 8211–8220. doi:10.1039/c5ob01095k
24. Shaw, A. Y.; Xu, Z.; Hulme, C. *Tetrahedron Lett.* **2012**, *53*, 1998–2000. doi:10.1016/j.tetlet.2012.02.030
25. Xu, Z.; Martinez-Ariza, G.; Cappelli, A. P.; Roberts, S. A.; Hulme, C. *J. Org. Chem.* **2015**, *80*, 9007–9015. doi:10.1021/acs.joc.5b00955
26. Balalaie, S.; Saeedi, S.; Ramezanzpour, S. *Helv. Chim. Acta* **2016**, *99*, 138–142. doi:10.1002/hlca.201500187
27. Konstantinidou, M.; Kurpiewska, K.; Kalinowska-Tluscik, J.; Dömling, A. *Eur. J. Org. Chem.* **2018**, 6714–6719. doi:10.1002/ejoc.201801276
28. Liao, W.-L.; Li, S.-Q.; Wang, J.; Zhang, Z.-Y.; Yang, Z.-W.; Xu, D.; Xu, C.; Lan, H.-T.; Chen, Z.-Z.; Xu, Z.-G. *ACS Comb. Sci.* **2016**, *18*, 65–69. doi:10.1021/acscombsci.5b00145
29. Caputo, S.; Basso, A.; Moni, L.; Riva, R.; Rocca, V.; Banfi, L. *Beilstein J. Org. Chem.* **2016**, *12*, 139–143. doi:10.3762/bjoc.12.15
30. Zheng, Q.; Mi, N.; Fan, Z.; Zuo, X.; Zhang, H.; Wang, H.; Yang, Z. *J. Agric. Food Chem.* **2010**, *58*, 7846–7855. doi:10.1021/jf1006193
31. Sheikhhosseini, E.; Balalaie, S.; Bigdeli, M. A.; Habibi, A.; Moghaddam, H. P. *J. Korean Chem. Soc.* **2014**, *58*, 186–192. doi:10.5012/jkcs.2014.58.2.186
32. Kumar, S.; Mukesh, K.; Harjai, K.; Singh, V. *Tetrahedron Lett.* **2019**, *60*, 8–12. doi:10.1016/j.tetlet.2018.11.030
33. Alavijeh, N. S.; Ramezanzpour, S.; Alavijeh, M. S.; Balalaie, S.; Rominger, F.; Misra, A.; Bijanzadeh, H. R. *Monatsh. Chem.* **2014**, *145*, 349–356. doi:10.1007/s00706-013-1098-0
34. Plant, A.; Thompson, P.; Williams, D. M. *J. Org. Chem.* **2009**, *74*, 4870–4873. doi:10.1021/jo900244m
35. Beaumont, S.; Retailliau, P.; Dauban, P.; Dodd, R. H. *Eur. J. Org. Chem.* **2008**, 5162–5175. doi:10.1002/ejoc.200800643
36. Van den Bogaert, A. M.; Nelissen, J.; Ovaere, M.; Van Meervelt, L.; Compemolle, F.; De Borggraeve, W. M. *Eur. J. Org. Chem.* **2010**, 5397–5401. doi:10.1002/ejoc.201000549
37. Mahdavi, M.; Hassanzadeh-Soureshjan, R.; Saeedi, M.; Ariafard, A.; BabaAhmadi, R.; Ranjbar, P. R.; Shafiee, A. *RSC Adv.* **2015**, *5*, 101353–101361. doi:10.1039/c5ra17056g
38. Purohit, P.; Pandey, A. K.; Kumar, B.; Chauhan, P. M. S. *RSC Adv.* **2016**, *6*, 21165–21186. doi:10.1039/c5ra27090a
39. Madhavachary, R.; Naveen, N.; Wang, Y.; Wang, Q.; Konstantinidou, M.; Dömling, A. *Eur. J. Org. Chem.* **2018**, 3139–3143. doi:10.1002/ejoc.201800557
40. Pandey, S.; Khan, S.; Singh, A.; Gauniyal, H. M.; Kumar, B.; Chauhan, P. M. S. *J. Org. Chem.* **2012**, *77*, 10211–10227. doi:10.1021/jo3018704
41. Balalaie, S.; Bararjanian, M.; Hosseinzadeh, S.; Rominger, F.; Bijanzadeh, H. R.; Wolf, E. *Tetrahedron* **2011**, *67*, 7294–7300. doi:10.1016/j.tet.2011.07.052
42. Rasouli, M. A.; Mahdavi, M.; Firoozpour, L.; Shafiee, A.; Foroumadi, A. *Tetrahedron* **2014**, *70*, 3931–3934. doi:10.1016/j.tet.2014.03.079
43. Al-Tel, T. H.; Al-Qawasmeh, R. A.; Voelter, W. *Eur. J. Org. Chem.* **2010**, 5586–5593. doi:10.1002/ejoc.201000808
44. Castellano, T. G.; Neo, A. G.; Marcaccini, S.; Marcos, C. F. *Org. Lett.* **2012**, *14*, 6218–6221. doi:10.1021/ol302976g
45. Chebanov, V. A.; Sakhno, Y. I.; Desenko, S. M.; Chernenko, V. N.; Musatov, V. I.; Shishkina, S. V.; Shishkin, O. V.; Kappe, C. O. *Tetrahedron* **2007**, *63*, 1229–1242. doi:10.1016/j.tet.2006.11.048
46. Murlykina, M. V.; Sakhno, Y. I.; Desenko, S. M.; Konovalova, I. S.; Shishkin, O. V.; Sysoiev, D. A.; Kornet, M. N.; Chebanov, V. A. *Tetrahedron* **2013**, *69*, 9261–9269. doi:10.1016/j.tet.2013.08.055
47. Sakhno, Y. I.; Murlykina, M. V.; Morozova, A. D.; Kozyryev, A. V.; Chebanov, V. A. *Fr.-Ukr. J. Chem.* **2015**, *3*, 1–20. doi:10.17721/fujcv3i2p1-20

48. Murlykina, M. V.; Morozova, A. D.; Zviagin, I. M.; Sakhno, Y. I.; Desenko, S. M.; Chebanov, V. A. *Front. Chem. (Lausanne, Switz.)* **2018**, *6*, 527–569. doi:10.3389/fchem.2018.00527
49. Sakhno, Y. I.; Kozyryev, A. V.; Desenko, S. M.; Shishkina, S. V.; Musatov, V. I.; Sysoiev, D. O.; Chebanov, V. A. *Tetrahedron* **2018**, *74*, 564–571. doi:10.1016/j.tet.2017.12.031
50. Sakhno, Y. I.; Desenko, S. M.; Shishkina, S. V.; Shishkin, O. V.; Sysoyev, D. O.; Groth, U.; Kappe, C. O.; Chebanov, V. A. *Tetrahedron* **2008**, *64*, 11041–11049. doi:10.1016/j.tet.2008.09.089
51. Murlykina, M. V.; Sakhno, Y. I.; Desenko, S. M.; Shishkina, S. V.; Shishkin, O. V.; Sysoiev, D. O.; Kornet, M. N.; Schols, D.; Goeman, J. L.; Van der Eycken, J.; Van der Eycken, E. V.; Chebanov, V. A. *Eur. J. Org. Chem.* **2015**, 4481–4492. doi:10.1002/ejoc.201500469
52. Annan, N.; Paris, R.; Jordan, F. *J. Am. Chem. Soc.* **1989**, *111*, 8895–8901. doi:10.1021/ja00206a019
53. Meng, Q.; Zhu, L.; Zhang, Z. *J. Org. Chem.* **2008**, *73*, 7209–7212. doi:10.1021/jo801140j
54. Albert, A., Ed. *Selective Toxicity: the physico-chemical basis of therapy*, 7th ed.; Springer: Netherlands, 1985. doi:10.1007/978-94-009-4846-4

## License and Terms

This is an Open Access article under the terms of the Creative Commons Attribution License (<http://creativecommons.org/licenses/by/4.0>). Please note that the reuse, redistribution and reproduction in particular requires that the authors and source are credited.

The license is subject to the *Beilstein Journal of Organic Chemistry* terms and conditions: (<https://www.beilstein-journals.org/bjoc>)

The definitive version of this article is the electronic one which can be found at: [doi:10.3762/bjoc.15.126](https://doi.org/10.3762/bjoc.15.126)



# One-pot activation–alkynylation–cyclization synthesis of 1,5-diacyl-5-hydroxypyrazolines in a consecutive three-component fashion

Christina Görgen<sup>1</sup>, Katharina Boden<sup>1</sup>, Guido J. Reiss<sup>2</sup>, Walter Frank<sup>2</sup> and Thomas J. J. Müller<sup>\*1</sup>

## Full Research Paper

Open Access

### Address:

<sup>1</sup>Heinrich-Heine Universität Düsseldorf, Institut für Organische Chemie und Makromolekulare Chemie, Universitätsstraße 1, D-40225 Düsseldorf, Germany and <sup>2</sup>Heinrich-Heine Universität Düsseldorf, Institut für Anorganische Chemie und Makromolekulare Chemie, Universitätsstraße 1, D-40225 Düsseldorf, Germany

### Email:

Thomas J. J. Müller<sup>\*</sup> - ThomasJJ.Mueller@uni-duesseldorf.de

\* Corresponding author

### Keywords:

activation; alkynylation; C–C coupling; copper; cyclization; multicomponent reactions

*Beilstein J. Org. Chem.* **2019**, *15*, 1360–1370.

doi:10.3762/bjoc.15.136

Received: 29 March 2019

Accepted: 28 May 2019

Published: 19 June 2019

This article is part of the thematic issue "Multicomponent reactions III" and is dedicated to Prof. Dr. Dr. h.c. mult. Peter Langer on the occasion of his 50th birthday.

Associate Editor: D. Spring

© 2019 Görgen et al.; licensee Beilstein-Institut.  
License and terms: see end of document.

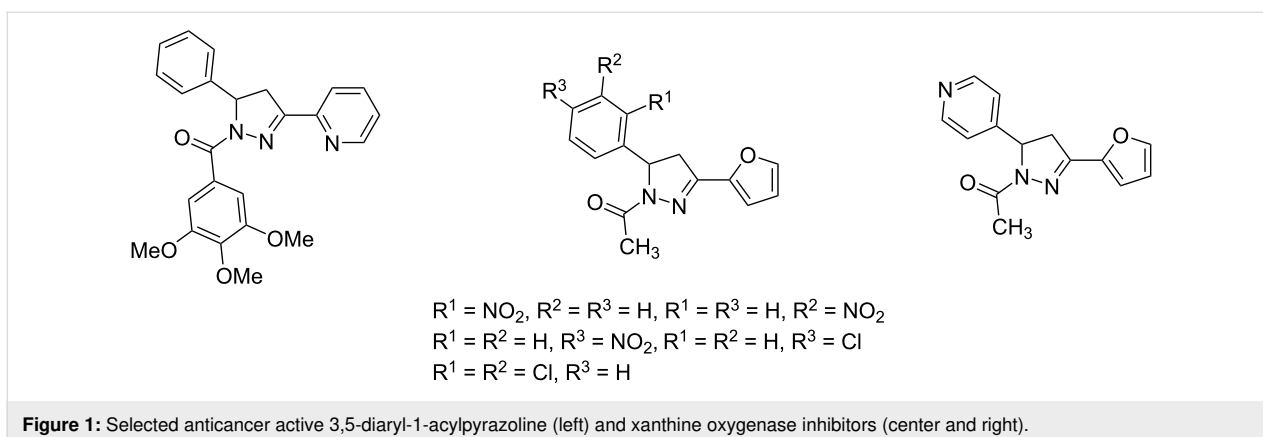
## Abstract

A consecutive three-component activation–alkynylation–cyclization reaction of (hetero)aryl glyoxylic acids, oxalyl chloride, aryl-acetylenes, and hydrazides efficiently forms 1,5-diacyl-5-hydroxypyrazolines in moderate to good yields. The structures were unambiguously corroborated by comprehensive NMR spectroscopy and X-ray structure analyses of selected derivatives.

## Introduction

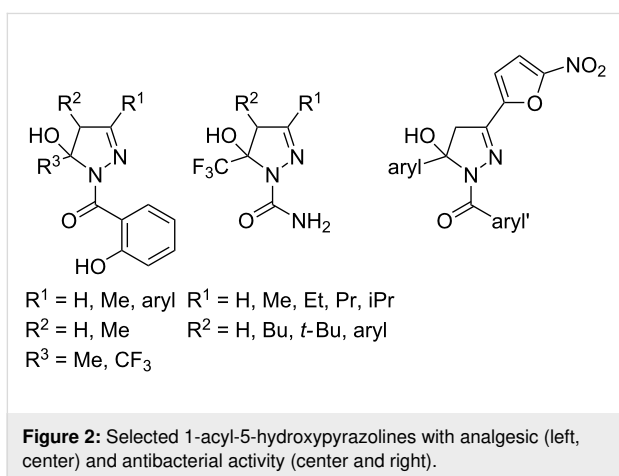
Pyrazoles [1,2] and pyrazolines [3–5] are privileged 1,2-diazole derivatives in a broad range of application, both in life and materials sciences. While the former are fully conjugated and can be considered as heteroaromatic  $6\pi$ -systems with interesting properties as crop-protecting agents [6,7], as pharmaceutically active ingredients [8–11], as ligands [12,13], and as chromophores [14–16], the partially unsaturated *2H*-pyrazolines have particularly attracted attention for instance as antibacterial [17], anti-inflammatory [18], antidiabetic [19], and antidepres-

sive [20] agents. Especially, 1-acylpyrazolines have shown nanomolar in vitro activities against chloroquine-sensitive and resistant strains of *Plasmodium falciparum* and can therefore be considered for the treatment of malaria [21]. Furthermore, similar derivatives have shown micromolar and submicromolar activity against 60 selected cancer cell lines, presumably by inhibition of microtubuli formation in cancer cells [22]. More specifically, a series of 60 1,3-diaryl-1-acylpyrazolines was tested as xanthine oxygenase inhibitors that can be efficacious



against articular gout, cancer, and inflammation, with  $\text{IC}_{50}$  values of four derivatives in the range of 5.3–15.2  $\mu\text{M}$  (Figure 1) [23].

1-Acyl-5-hydroxypyrazolines have been shown to be analgesics with a slightly improved pain-relieving efficacy than Aspirin<sup>®</sup> [24,25], and 5-nitro-2-furyl-substituted derivatives are active antibacterials against the strains *S. aureus*, *A. aerogenes*, *E. coli* and *B. subtilis* (Figure 2) [26,27].



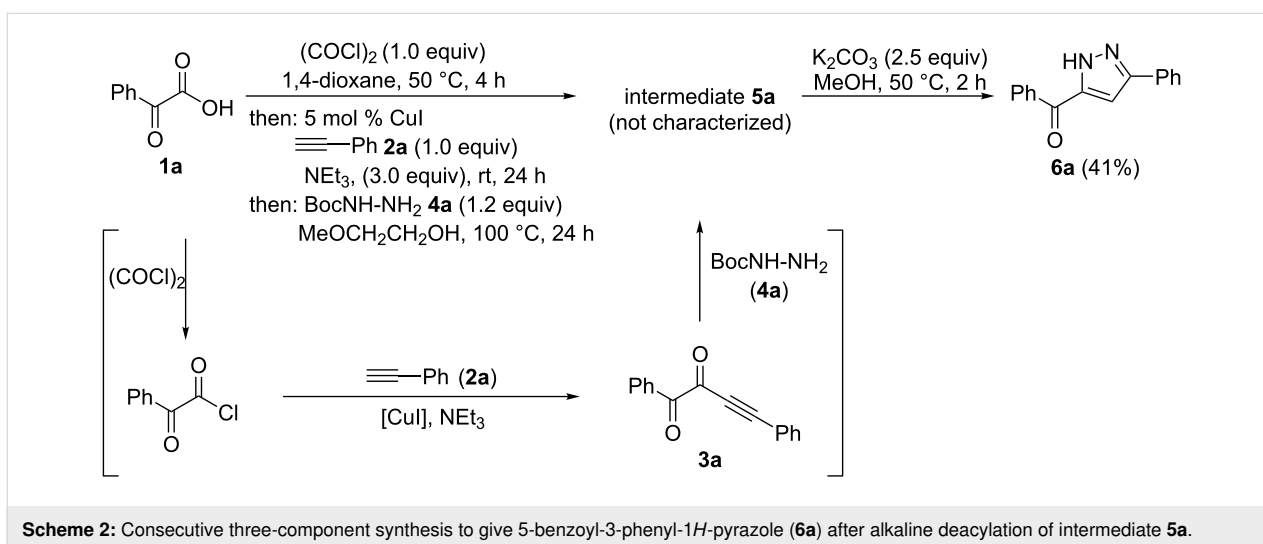
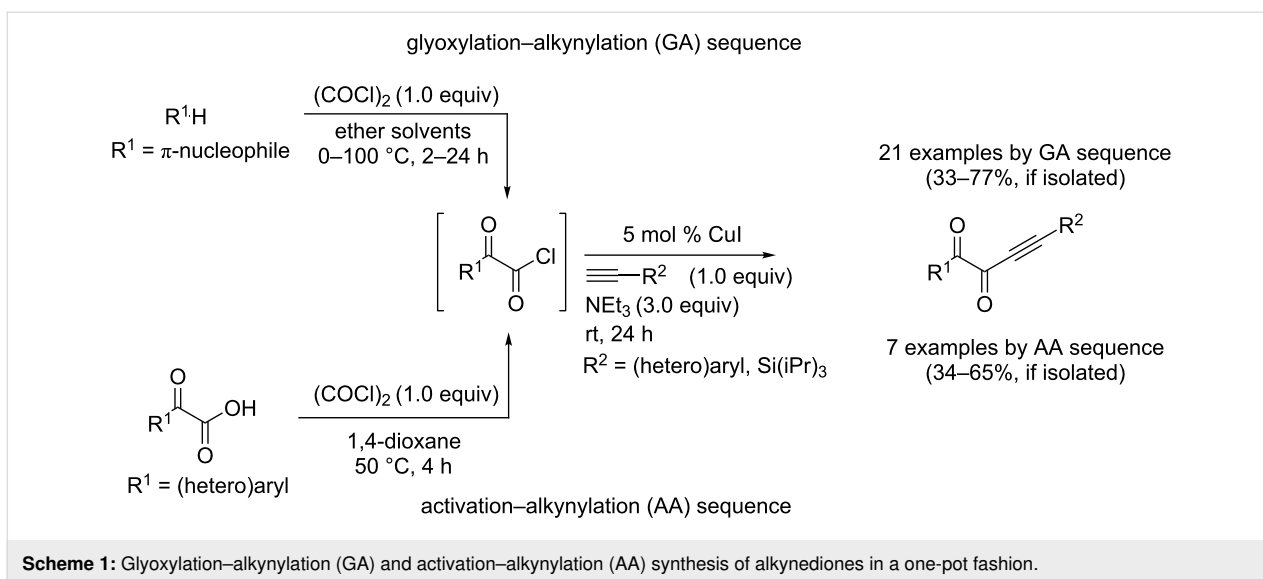
In addition, 1-acyl-5-hydroxypyrazolines are bidentate ligands for zinc complexes and by virtue of being ring tautomers of  $\beta$ -enolhydrazones they can also act as tridentate ligands for nickel [28] and tin [29,30] complexes. In contrast, dimethylzinc forms dimeric complexes where the 1-acyl-5-hydroxypyrazoline acts as a bidentate ligand [31]. Upon treatment with TMEDA mononuclear complexes with concomitant ring opening to give a seven-membered bidentate chelate are generated.

Although numerous syntheses of pyrazolines [3–5] in general and 1-acyl-5-hydroxypyrazolines [24–26] specifically have been

published employing a cyclizing addition of an acylhydrazone to the carbonyl group as a ring-forming reaction [32–40], their diversity-oriented one-pot synthesis in a multicomponent approach has remained unexplored to date. In the course of our program directed to develop multicomponent syntheses of heterocycles by transition-metal catalysis [41,42] we conceptualized catalytic entries to alkynones and alkynediones as suitable intermediates in addition–cyclocondensation syntheses of numerous heterocycles, which can indeed be prepared by consecutive multicomponent reactions [43–47]. Particularly interesting are alkynediones, because, as densely functionalized trielectrophiles, the alkyne, ynone and dicarbonyl functionalities can be selectively addressed. We have established two complementary one-pot pathways to alkynediones, a glyoxylation–alkynylation (GA) [48] and an activation–alkynylation (AA) [49] sequence, which both take advantage of a copper-catalyzed alkynylation of the intermediary formed (hetero)aryl glyoxyl chloride (Scheme 1). The alkynediones can be subsequently transformed, still in the same reaction vessel, to quinoxalines [48,50–52], pyrimidines [48,49], and 5-acylpyrazoles [48,49]. The latter 5-acylpyrazole arose after work-up from the three-component AA–cyclocondensation synthesis employing Boc-hydrazine as a binucleophilic hydrazide substrate. Based on our attempts to isolate potential 1,5-diacylpyrazole precursors we discovered that 1,5-diacyl-5-hydroxypyrazolines are the intermediary products. Here, we report on the novel three-component AA–condensation–cyclization synthesis of 1,5-diacyl-5-hydroxypyrazolines.

## Results and Discussion

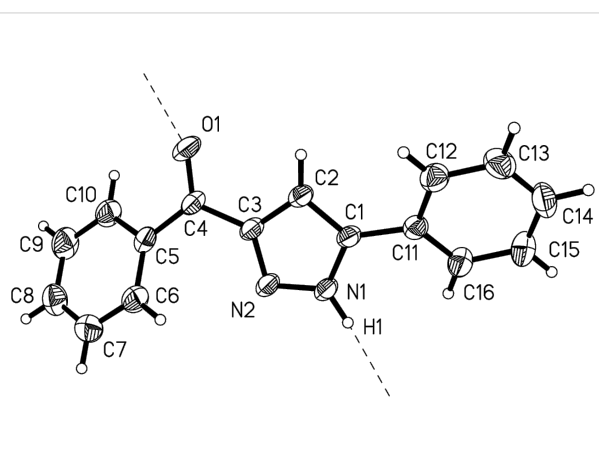
In our initial study [49], the three-component AA–cyclocondensation synthesis, starting from phenylglyoxylic acid (**1a**), phenylacetylene (**2a**), and Boc-hydrazide (**4a**) through the formation of 1,4-diphenylbut-3-yne-1,2-dione (**3a**), with subsequent *N*-deacylation as the consequence of basic work-up (Scheme 2), furnished 5-benzoyl-3-phenyl-1*H*-pyrazole (**6a**) in 41% isolated yield.



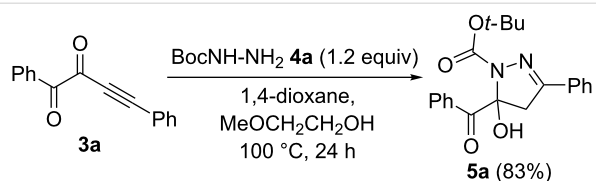
In addition to spectroscopic assignment the structure of **6a** has now been corroborated by an X-ray structure analysis showing infinite chains of molecules **6a** formed by intermolecular hydrogen bonding between the pyrazole N1 and the carbonyl O1 (Figure 3) [53].

The first assumption was that the tentative intermediate **5a** could be a 1,5-diacetylpyrazole. However, upon performing the terminal cyclization step starting from 1,4-diphenylbut-3-yn-1,2-dione (**3a**) and Boc-hydrazine (**4a**) under identical conditions 1-Boc-5-benzoyl-5-hydroxypyrazoline was isolated in 83% yield (Scheme 3).

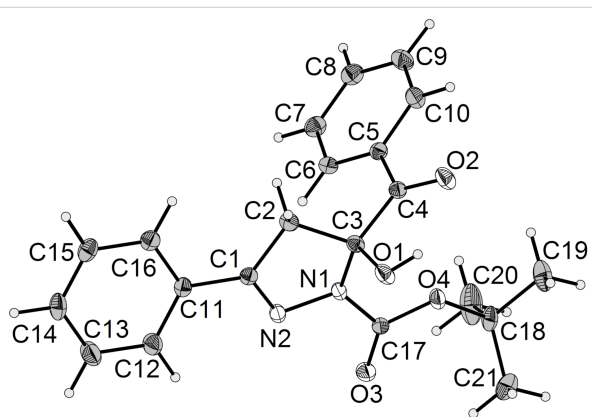
The molecular structure was additionally corroborated by X-ray structure analysis showing that the assignment of intermediate **5a** was not a fully unsaturated pyrazole (Figure 4) [53].



**Figure 3:** ORTEP plot of 5-benzoyl-3-phenyl-1*H*-pyrazole (**6a**) (thermal ellipsoids at 30% probability); the direction of intermolecular N–H...O hydrogen bonding is indicated by dashed lines.



**Scheme 3:** Cyclization of 1,4-diphenylbut-3-yne-1,2-dione (**3a**) and Boc-hydrazine (**4a**) to give intermediate **5a**.



**Figure 4:** Ellipsoid plot of 1-Boc-5-benzoyl-5-hydroxypyrazoline **5a**.

Therefore, we set out to optimize the one-pot synthesis of 1,5-diacyl-5-hydroxypyrazolines by choosing the model reaction of phenylglyoxylic acid (**1a**), phenylacetylene (**2a**), and benzoyl hydrazide (**4b**) giving 1,5-diacyl-5-hydroxypyrazoline **5b**, where the reaction times  $t_1$  and  $t_2$ , as well as the conditions of the cyclization step needed to be optimized (Scheme 4).

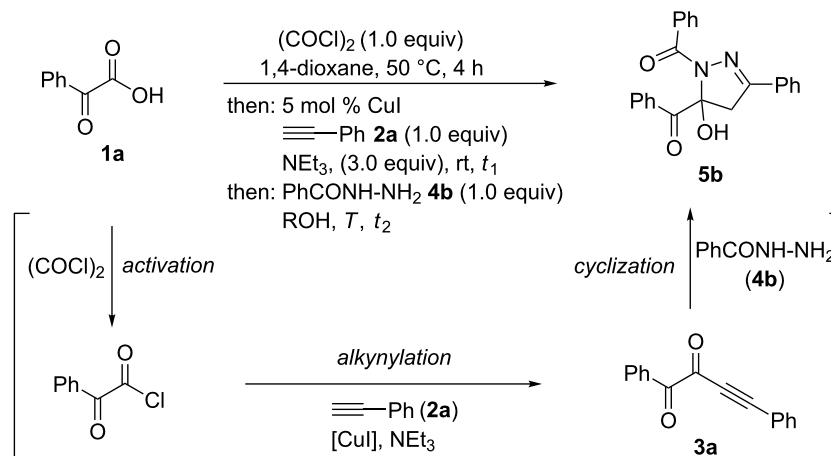
A quick optimization screening of the activation–alkynylation synthesis of 1,4-diphenylbut-3-yne-1,2-dione (**3a**) revealed that the use of KOH dried triethylamine instead of the initial precon-

ditioning (Na/benzophenone dried) led to a reduction of the reaction time  $t_1$  from 24 to 15 h (see Supporting Information File 1, Table S1). In addition, the concentration could be doubled and the obtained yield of diphenylbut-3-yne-1,2-dione (**3a**) increased from 63 to 76%.

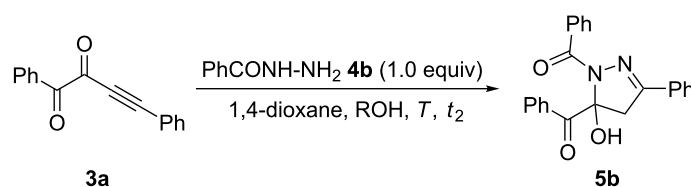
The terminal cyclization step, consisting of a Michael addition of benzoyl hydrazide (**4b**) to diphenylbut-3-yne-1,2-dione (**3a**) followed by a cyclizing addition of the central hydrazide nitrogen atom to the carbonyl group, was monitored by GC–MS and optimized with respect to temperature  $T$ , reaction time  $t_2$ , and the alcohol additive (Table 1).

A ratio of 1.2 equiv of hydrazide **4b** to 1.0 equiv of **3a** turned to be optimal for achieving full conversion (Table 1, entries 7–16) and at a reaction temperature of 175 °C the reaction time of 5 min was identified to achieve full conversion with very good to excellent yields of isolated 1,5-diacyl-5-hydroxypyrazoline **5b** (Table 1, entries 12–16). Although ethylene glycol as a cosolvent (Table 1, entry 13) gave slightly higher yields and ethanol furnished slightly lower yields (Table 1, entry 14), 2-methoxyethanol not only gave high yields of **5b**, but also proved to be practical with respect to work-up. Upon comparison between dielectric and conductive heating the reaction in the microwave cavity gave no detectable difference in reaction time and yield. All these optimized conditions were therefore directly employed in the consecutive one-pot sequence. However, some adjustments in the final step were necessary because an increase of pressure was detected under dielectric heating. Therefore, the consecutive process was optimized with respect to the terminal step (Table 2).

In the sequence dielectric heating gave considerably lower yields (Table 2, entries 1–3) than in the separated process

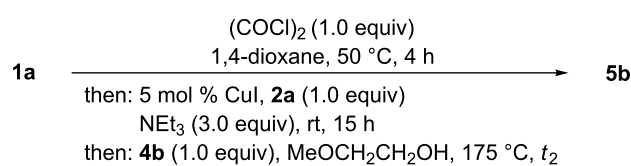


**Scheme 4:** Model reaction for optimizing the activation–alkynylation–cyclization synthesis of 1,5-diacyl-5-hydroxypyrazoline **5b**.

**Table 1:** Optimization of the cyclization step of 1,5-diacyl-5-hydroxypyrazoline **5b**.<sup>a</sup>

entry	ROH [mL]	$T$ [°C]	$t_2$ [min]	1,5-diacyl-5-hydroxypyrazoline <b>5b</b> (%) <sup>b</sup>
1 <sup>c,d</sup>	2-methoxyethanol (0.2)	100	60	incomplete conversion <sup>e</sup> (n.i.)
2 <sup>c,d</sup>	2-methoxyethanol (0.2)	150	60	incomplete conversion <sup>e</sup> (n.i.)
3 <sup>d,f</sup>	2-methoxyethanol (0.2)	150	60	complete conversion <sup>e</sup> (n.i.)
4 <sup>d,g</sup>	2-methoxyethanol (0.2)	150	60	complete conversion <sup>e</sup> (n.i.)
5 <sup>d,h</sup>	2-methoxyethanol (0.2)	150	60	complete conversion <sup>e</sup> (n.i.)
6 <sup>d,i</sup>	2-methoxyethanol (0.2)	150	60	incomplete conversion <sup>e</sup> (n.i.)
7 <sup>d,h</sup>	2-methoxyethanol (0.2)	150	30	complete conversion <sup>e</sup> (n.i.)
8 <sup>d,h</sup>	2-methoxyethanol (0.2)	150	15	complete conversion <sup>e</sup> (n.i.)
9 <sup>d,h</sup>	2-methoxyethanol (0.2)	150	5	incomplete conversion <sup>e</sup> (n.i.)
10 <sup>d,h</sup>	2-methoxyethanol (0.2)	100	10	incomplete conversion <sup>e</sup> (n.i.)
11 <sup>d,h</sup>	2-methoxyethanol (0.2)	125	10	incomplete conversion <sup>e</sup> (n.i.)
12 <sup>d,h,j</sup>	<b>2-methoxyethanol (0.2)</b>	<b>175</b>	<b>5</b>	<b>full conversion<sup>e</sup> (94)</b>
13 <sup>d,h,j</sup>	ethylene glycol (0.2)	175	5	full conversion <sup>e</sup> (96)
14 <sup>d,h,j</sup>	ethanol (0.2)	175	5	full conversion <sup>e</sup> (87)
15 <sup>k</sup>	<b>2-methoxyethanol (0.2)</b>	<b>175</b>	<b>5</b>	<b>full conversion<sup>e</sup> (90)</b>
16 <sup>h,l,j</sup>	2-methoxyethanol (0.2)	175	5	full conversion <sup>e</sup> (93)

<sup>a</sup> $c_0$ (**3a**) = 0.17 M; 1,4-dioxane (1.0 mL). <sup>b</sup>Isolated yield (n.i. = not isolated). <sup>c</sup> $c_0$ (**4b**) = 0.17 M. <sup>d</sup>Dielectric heating in a microwave cavity ( $T$  is the set temperature and  $t_2$  is the hold time). <sup>e</sup>As monitored by GC-MS. <sup>f</sup> $c_0$ (**4b**) = 0.25 M. <sup>g</sup> $c_0$ (**4b**) = 0.21 M. <sup>h</sup> $c_0$ (**4b**) = 0.20 M. <sup>i</sup> $c_0$ (**4b**) = 0.18 M. <sup>j</sup>On a 1.00 mmol scale (**3a**). <sup>k</sup>On a 1.00 mmol scale (**3a**),  $c_0$ (**3a**) = 0.34 M;  $c_0$ (**4b**) = 0.40 M. 1,4-Dioxane (1.0 mL). <sup>l</sup>Conductive heating in an oil bath at preheated temperature  $T$ .

**Table 2:** Optimization of the consecutive three-component synthesis of 1,5-diacyl-5-hydroxypyrazoline **5b**.

entry	$c_0$ ( <b>1a</b> )	$t_2$ [min]	1,5-diacyl-5-hydroxypyrazoline <b>5b</b> , yield [%] <sup>a</sup>
1 <sup>b</sup>	0.4 M	5	37
2 <sup>b</sup>	0.25 M	5	32
3 <sup>b</sup>	0.25 M	10	35
4 <sup>c</sup>	0.4 M	10	no product formation <sup>d</sup>
5 <sup>e,f</sup>	0.4 M	5	no product formation <sup>d</sup>
6 <sup>e</sup>	0.4 M	10	64
7 <sup>e</sup>	0.4 M	20	69
8 <sup>e</sup>	<b>0.4 M</b>	<b>30</b>	<b>78</b>
9 <sup>e</sup>	0.4 M	45	79

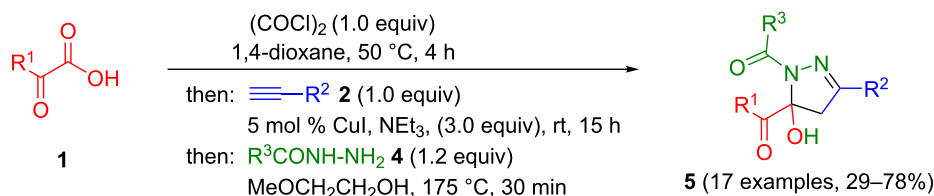
<sup>a</sup>Isolated yield. <sup>b</sup>Dielectric heating in a microwave cavity ( $T$  is set to 175 °C and  $t_2$  is the hold time). <sup>c</sup>Dielectric heating in a microwave cavity ( $T$  is set to 150 °C and  $t_2$  is the hold time). <sup>d</sup>As monitored by GC-MS. <sup>e</sup>Conductive heating in an oil bath at preheated temperature  $T = 175$  °C. <sup>f</sup>2.00 equiv of  $\text{NEt}_3$  were added.

(Table 1, entries 12–15). However, conductive heating, which already gave comparable results in the terminal cyclization step (Table 1, entry 16), is obviously better suited to achieve full conversion and, ultimately, slightly longer heating also gives rise to good yields (Table 2, entries 6–9).

Taking into account the combined yield of 71% for both individually performed steps (ynedione formation with 76% and cyclization with 94%) is slightly lower than that of the one-pot sequence with 78% (Table 2, entry 8), the consecutive three-component process clearly is superior. With four bond-forming steps (activation, alkylation, Michael addition, and cyclization) the average yield per bond-forming step accounts to 94%.

With the optimized conditions of the consecutive three-component synthesis in hand (hetero)arylglyoxylic acids **1**, oxalyl chloride, arylacetylenes **2**, and hydrazides **4** were reacted in 1,4-dioxane and in the presence of catalytic amounts of copper(I) iodide in a one-pot activation–alkynylation–cyclization sequence to give 1,5-diacyl-5-hydroxypyrazoline **5** after flash chromatography on silica gel in moderate to good yields (Scheme 5, Table 3).

The structures of the 1,5-diacyl-5-hydroxypyrazolines **5** were unambiguously assigned by  $^1\text{H}$  and  $^{13}\text{C}$  NMR spectroscopy, in selected cases by NOESY, HSQC, and HMBC experiments, as well as by EI mass spectrometry and the elemental composition

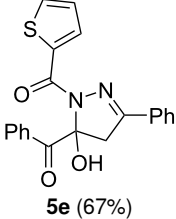
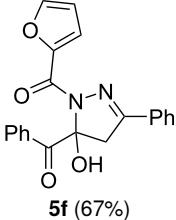
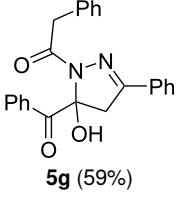
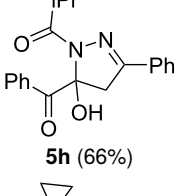
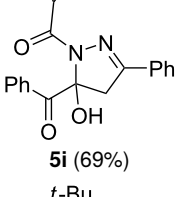
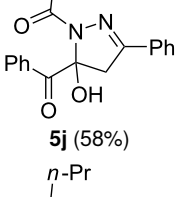
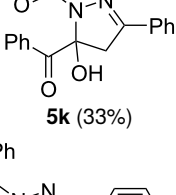
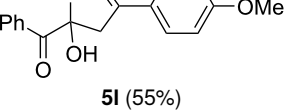


**Scheme 5:** One-pot activation–alkynylation–cyclization synthesis of 1,5-diacyl-5-hydroxypyrazolines **5**.

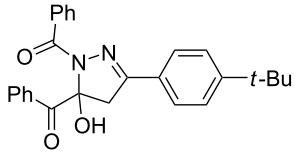
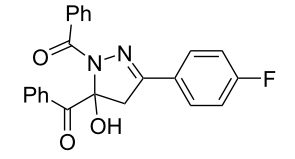
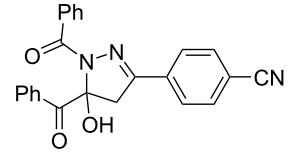
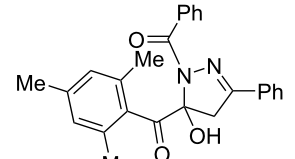
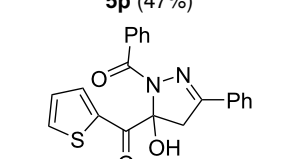
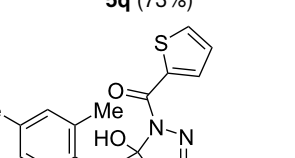
**Table 3:** Consecutive three-component synthesis of 1,5-diacyl-5-hydroxypyrazolines **5**.

entry	glyoxylic acid $\text{R}^1\text{COCO}_2\text{H}$ <b>1</b>	alkyne $\text{R}^2\text{C}\equiv\text{CH}$ <b>2</b>	hydrazide $\text{R}^3\text{CONHNH}_2$ <b>4</b>	1,5-diacyl-5-hydroxypyrazoline <b>5</b> yield
1	$\text{R}^1 = \text{Ph}$ ( <b>1a</b> )	$\text{R}^2 = \text{Ph}$ ( <b>2a</b> )	$\text{R}^3 = \text{Ph}$ ( <b>4b</b> )	 <b>5b</b> (78%)
2 <sup>a</sup>	<b>1a</b>	<b>2a</b>	$\text{R}^3 = p\text{-MeC}_6\text{H}_4$ ( <b>4c</b> )	 <b>5c</b> (55%)
3	<b>1a</b>	<b>2a</b>	$\text{R}^3 = p\text{-BrC}_6\text{H}_4$ ( <b>4d</b> )	 <b>5d</b> (41%)

**Table 3:** Consecutive three-component synthesis of 1,5-diacyl-5-hydroxypyrazolines **5**. (continued)

4	<b>1a</b>	<b>2a</b>	$R^3 = 2\text{-thienyl (4e)}$	 <p><b>5e (67%)</b></p>
5	<b>1a</b>	<b>2a</b>	$R^3 = 2\text{-furyl (4f)}$	 <p><b>5f (67%)</b></p>
6	<b>1a</b>	<b>2a</b>	$R^3 = \text{PhCH}_2 \text{ (4g)}$	 <p><b>5g (59%)</b></p>
7	<b>1a</b>	<b>2a</b>	$R^3 = i\text{Pr (4h)}$	 <p><b>5h (66%)</b></p>
8	<b>1a</b>	<b>2a</b>	$R^3 = \text{cyclopropyl (4i)}$	 <p><b>5i (69%)</b></p>
9	<b>1a</b>	<b>2a</b>	$R^3 = t\text{-Bu (4j)}$	 <p><b>5j (58%)</b></p>
10	<b>1a</b>	<b>2a</b>	$R^3 = n\text{-Pr (4k)}$	 <p><b>5k (33%)</b></p>
11	<b>1a</b>	$R^2 = p\text{-MeOC}_6\text{H}_4 \text{ (2b)}$	<b>4b</b>	 <p><b>5l (55%)</b></p>

**Table 3:** Consecutive three-component synthesis of 1,5-diacyl-5-hydroxypyrazolines **5**. (continued)

12	<b>1a</b>	$R^2 = p\text{-}t\text{-BuC}_6\text{H}_4$ ( <b>2c</b> )	<b>4b</b>	 <b>5m</b> (69%)
13	<b>1a</b>	$R^2 = p\text{-FC}_6\text{H}_4$ ( <b>2d</b> )	<b>4b</b>	 <b>5n</b> (66%)
14	<b>1a</b>	$R^2 = p\text{-NCC}_6\text{H}_4$ ( <b>2e</b> )	<b>4b</b>	 <b>5o</b> (29%)
15	$R^1 = 2,4,6\text{-Me}_3\text{C}_6\text{H}_2$ ( <b>1b</b> )	<b>2a</b>	<b>4b</b>	 <b>5p</b> (47%)
16	$R^1 = 2\text{-thienyl}$ ( <b>1c</b> )	<b>2a</b>	<b>4b</b>	 <b>5q</b> (73%)
17	<b>1b</b>	<b>2b</b>	<b>4e</b>	 <b>5r</b> (38%)

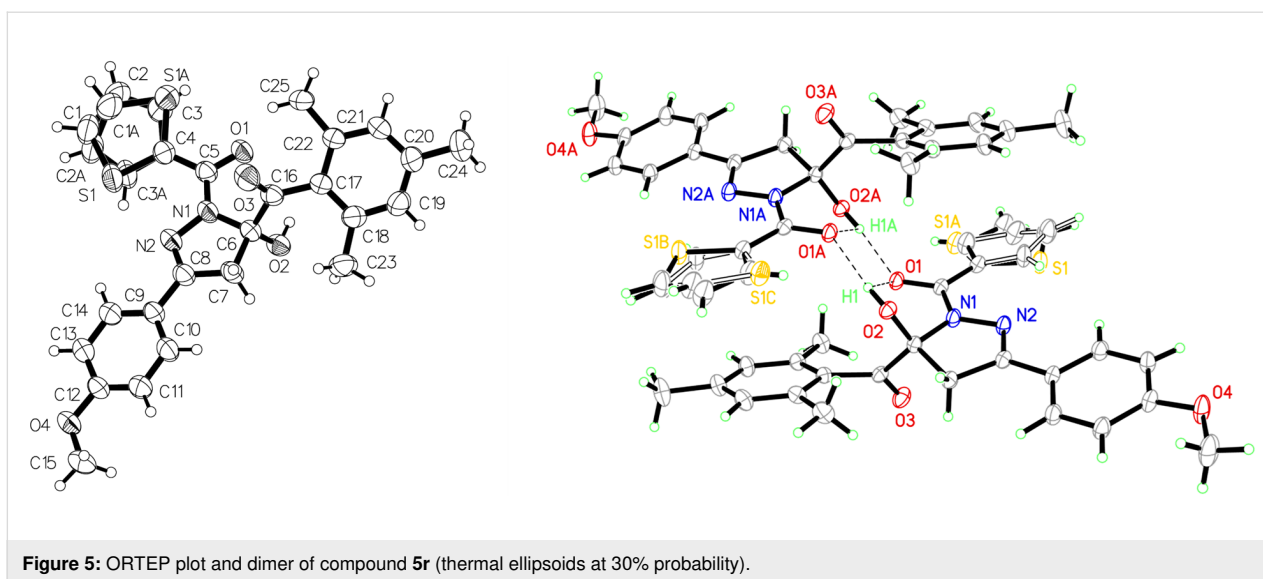
<sup>a</sup>Reaction time  $t_2 = 20$  min.

was confirmed by combustion analyses. Additionally, the structure was corroborated by an X-ray structure analysis of compound **5r** showing dimers held together by inter- and intramolecular hydrogen bonding (Figure 5) [53].

The three-component synthesis allows addressing three points of diversity and especially for the hydrazide substrate **4** all different types of (hetero)aromatic, aliphatic, and alicyclic substituents  $R^3$  are well tolerated in the sequence (Table 3, entries 1–10). The alkynes **2** can bear electron-donating and electron-

withdrawing substituents  $R^2$  (Table 3, entries 1, 11–14), however, for the electron-poor cyano substituent a somewhat lower yield of the title compound is obtained (Table 3, entry 14). Finally, the substituents  $R^1$  of the glyoxylic acids **1** can be aromatic, heteroaromatic and even sterically demanding (Table 3, entries 1, 15–17).

All attempts to dehydrate 1,5-diacyl-5-hydroxypyrazoline **5b** under alkaline or Brønsted acidic conditions were accompanied by simultaneous deacylation of substituent  $R^3$  finally furnishing



5-(hetero)aryl-3-(hetero)aryl-1*H*-pyrazole **6a** (for attempted dehydrative aromatization, see Supporting Information File 1, Table S5), as already reported for alkaline deprotection–aromatization [49]. However, compound **5b** is stable against water and weakly basic conditions. This indicates that 1,5-diacyl-5-hydroxypyrazolines might act as acyl transferring agents under certain conditions.

## Conclusion

In summary we could elucidate that the consecutive three-component activation–alkynylation–cyclization sequence of (hetero)arylglyoxylic acids, oxalyl chloride, arylacetylenes, and hydrazides does not form aromatic pyrazoles, but rather 1,5-diacyl-5-hydroxypyrazolines, i.e., the aromatizing elimination of water does not occur under these neutral conditions. This novel one-pot synthesis of 1,5-diacyl-5-hydroxypyrazolines is concise, highly efficient and diversity-oriented. The deacylating aromatization of the title compounds under weakly alkaline or acidic conditions indicates acyl-transfer ability. Furthermore, the peculiar reactivity of the ynedione intermediate calls for more sophisticated cyclizing processes, eventually in a one-pot fashion. Further studies exploring the dense electrophilic reactivity of ynediones in consecutive multicomponent reactions are still underway.

## Experimental

**Typical procedure for the three-component synthesis of compound 5b:** In an oven-dried Schlenk flask equipped with a magnetic stirring bar and screw cap were placed glyoxylic acid **1a** (150 mg, 1.00 mmol) and dry 1,4-dioxane (2.5 mL) under argon. Then, oxalyl chloride (0.09 mL, 1.00 mmol) was added dropwise at room temperature (external water bath) and the reaction mixture was stirred at 50 °C (preheated oil bath) for

4 h. After the mixture had cooled to room temperature, CuI (10 mg, 0.05 mmol), phenylacetylene (**2a**, 0.11 mL, 1.00 mmol), and dry triethylamine (0.42 mL, 3.00 mmol) were successively added. Stirring at room temperature (external water bath) was continued for 15 h. Then, phenylhydrazide (**3b**, 163 mg, 1.20 mmol) and 2-methoxyethanol (1.0 mL) were added and the reaction mixture was stirred at 175 °C (preheated oil bath) for 30 min. After cooling to room temperature deionized water (5 mL) was added and the mixture was extracted with dichloromethane (4 × 5 mL). The combined organic phases were dried with anhydrous sodium sulfate and the solvents were removed in vacuo. The crude product was adsorbed on celite<sup>®</sup> and purified by flash chromatography on silica gel (petroleum ether 40–60 °C/ethyl acetate 5:1) to give analytically pure 1,5-dibenzoyl-5-hydroxy-3-phenylpyrazoline (**5b**, 291 mg, 78%) as colorless solid.  $R_f = 0.15$  (petroleum ether/ethyl acetate 5:1, detected with a hand-held UV lamp at 254 and 365 nm). Mp 152 °C; <sup>1</sup>H NMR (CDCl<sub>3</sub>, 300 MHz) δ 3.54 (d,  $J = 18.5$  Hz, 1H), 3.76 (d,  $J = 18.5$  Hz, 1H), 5.60–6.08 (br, 1H), 7.36–7.62 (m, 9H), 7.72–7.83 (m, 2H), 7.90–8.05 (m, 4H); <sup>13</sup>C NMR (CDCl<sub>3</sub>, 75 MHz) δ 45.6 (CH<sub>2</sub>), 92.2 (C<sub>quat</sub>), 126.9 (CH), 127.8 (CH), 128.9 (CH)\*, 129.0 (CH), 130.2 (CH), 130.7 (C<sub>quat</sub>), 130.9 (CH), 131.7 (CH), 131.8 (C<sub>quat</sub>), 132.9 (C<sub>quat</sub>), 133.9 (CH), 153.1 (C<sub>quat</sub>), 166.7 (C<sub>quat</sub>), 193.4 (C<sub>quat</sub>); \*broadened signal; EIMS ( $m/z$ ): 352 ([M – H<sub>2</sub>O]<sup>+</sup>, 2), 266 (11), 265 ([M – PhCO]<sup>+</sup>, 59), 248 ([M – PhCO – H<sub>2</sub>O]<sup>+</sup>, 20), 105 (PhCO<sup>+</sup>, 100), 77 (C<sub>6</sub>H<sub>5</sub><sup>+</sup>, 34); IR (ATR),  $\tilde{\nu}$  [cm<sup>–1</sup>]: 3333 (w), 1697 (m), 1626 (m), 1612 (m), 1566 (w), 1450 (m), 1427 (m), 1339 (m), 1315 (w), 1254 (w), 1202 (m), 1180 (m), 1113 (m), 1057 (w), 1028 (w), 922 (w), 895 (w), 866 (m), 845 (w), 791 (w), 762 (m), 708 (s), 689 (s), 669 (m), 627 (w); anal. calcd for C<sub>23</sub>H<sub>18</sub>N<sub>2</sub>O<sub>3</sub> (370.4): C, 74.58; H, 4.90; N, 7.56; found: C, 74.67; H, 5.07; N, 7.79.

## Supporting Information

For experimental details of the optimization studies on intermediate **3a**, on the cyclization step of **3a** and **4b** (compound **5b**), on the consecutive three-component synthesis of compound **5b**, experimental details of general procedure of the consecutive three-component synthesis and analytical data of 1,5-diacyl-5-hydroxypyrazolines **5**, experimental details on the attempted dehydrative aromatization of compound **5b**, and NMR spectra of the compounds **5**, and for summaries on the crystal structure analyses of **5a**, **5r**, and **6a** see Supporting Information File 1.

### Supporting Information File 1

Experimental details, copies of NMR spectra and crystallographic data.

[<https://www.beilstein-journals.org/bjoc/content/supplementary/1860-5397-15-136-S1.pdf>]

## Acknowledgements

The support of this work by the Fonds der Chemischen Industrie is gratefully acknowledged.

## Statement

The reported results have been summarized in the inaugural dissertation "Diversitätsorientierte katalytische Ein-Topf-Synthesen von ausgewählten Azolderivaten" by Dr. Christina Boersch, Heinrich Heine University Düsseldorf, 2014. Dr. Christina Görgen (née Boersch) is the first author of this article.

## ORCID® iDs

Thomas J. J. Müller - <https://orcid.org/0000-0001-9809-724X>

## References

- Yet, L. Pyrazoles. In *Comprehensive Heterocyclic Chemistry III*; Katritzky, A. R.; Ramsden, C. A.; Scriven, E. F.; Taylor, R. J., Eds.; Elsevier: Oxford, 2008; Vol. 4, pp 3–141. doi:10.1016/b978-008044992-0.00401-6
- Götzinger, A. C.; Müller, T. J. J. 12.1.5 Pyrazoles (Update 2017). In *Science of Synthesis*; Carreira, E. M.; Christmann, M.; Reissig, H.-U.; Schaumann, E., Eds.; Georg Thieme Verlag: Stuttgart, New York, 2017; pp 1–228. doi:10.1055/sos-sd-112-00112
- Stanovnik, B.; Svete, J. Product Class 1: Pyrazoles. In *Category 2, Heterocycles and Related Ring Systems*; Neier, R.; Bellus, D., Eds.; *Science of Synthesis*; Georg Thieme Verlag: Stuttgart, New York, 2002; pp 15–225. doi:10.1055/sos-sd-012-00002
- Elguero, J.; Silva, A. M. S.; Tomé, A. C. Five-Membered Heterocycles: 1,2-Azoles. Part 1. Pyrazoles. In *Modern Heterocyclic Chemistry*; Alvarez-Builla, J.; Vaquero, J. J.; Barluenga, J., Eds.; Wiley-VCH: Weinheim, Germany, 2011; pp 635–725. doi:10.1002/9783527637737.ch8
- Eicher, T.; Hauptmann, S. *The Chemistry of Heterocycles*, 2nd ed.; Wiley-VCH: Weinheim, Germany, 2003; pp 186–189. doi:10.1002/352760183x
- Motoba, K.; Nishizawa, H.; Suzuki, T.; Hamaguchi, H.; Uchida, M.; Funayama, S. *Pestic. Biochem. Physiol.* **2000**, *67*, 73–84. doi:10.1006/pest.2000.2477
- Beckmann, M.; Haack, K.-J. *Chem. Unserer Zeit* **2003**, *37*, 88–97. doi:10.1002/ciuz.200300268
- Orth, R. E. *J. Pharm. Sci.* **1968**, *57*, 537–556. doi:10.1002/jps.2600570401
- Chauhan, A.; Sharma, P. K.; Kaushik, N. *Int. J. ChemTech Res.* **2011**, *3*, 11–17.
- Ismail, M. A. H.; Lehmann, J.; Abou El Ella, D. A.; Albohy, A.; Abouzid, K. A. M. *Med. Chem. Res.* **2009**, *18*, 725–744. doi:10.1007/s00044-009-9163-2
- Stauffer, S. R.; Coletta, C. J.; Tedesco, R.; Nishiguchi, G.; Carlson, K.; Sun, J.; Katzenellenbogen, B. S.; Katzenellenbogen, J. A. *J. Med. Chem.* **2000**, *43*, 4934–4947. doi:10.1021/jm000170m
- Singer, R. A.; Caron, S.; McDermott, R. E.; Arpin, P.; Do, N. M. *Synthesis* **2003**, 1727–1731. doi:10.1055/s-2003-40881
- Mukherjee, A.; Sarkar, A. *Tetrahedron Lett.* **2004**, *45*, 9525–9528. doi:10.1016/j.tetlet.2004.11.016
- Dorlars, A.; Schellhammer, C.-W.; Schroeder, J. *Angew. Chem., Int. Ed. Engl.* **1975**, *14*, 665–679. doi:10.1002/anie.197506651
- Catalan, J.; Fabero, F.; Claramunt, R. M.; Santa Maria, M. D.; de la Concepcion Foces-Foces, M.; Hernandez Cano, F.; Martinez-Ripoll, M.; Elguero, J.; Sastre, R. *J. Am. Chem. Soc.* **1992**, *114*, 5039–5048. doi:10.1021/ja00039a014
- Yang, Z.; Zhang, K.; Gong, F.; Li, S.; Chen, J.; Ma, J. S.; Sobenina, L. N.; Mikhaleva, A. I.; Trofimov, B. A.; Yang, G. *J. Photochem. Photobiol., A* **2011**, *217*, 29–34. doi:10.1016/j.jphotochem.2010.09.012
- Holla, B. S.; Akberali, P. M.; Shivananda, M. K. *Farmaco* **2000**, *55*, 256–263. doi:10.1016/s0014-827x(00)00030-6
- Bansal, E.; Srivastava, V. K.; Kumar, A. *Eur. J. Med. Chem.* **2001**, *36*, 81–92. doi:10.1016/s0223-5234(00)01179-x
- Ahn, J. H.; Kim, H.-M.; Jung, S. H.; Kang, S. K.; Kim, K. R.; Rhee, S. D.; Yang, S.-D.; Cheon, H. G.; Kim, S. S. *Bioorg. Med. Chem. Lett.* **2004**, *14*, 4461–4465. doi:10.1016/j.bmcl.2004.06.046
- Rajendra Prasad, Y.; Lakshmana Rao, A.; Prasoona, L.; Murali, K.; Ravi Kumar, P. *Bioorg. Med. Chem. Lett.* **2005**, *15*, 5030–5034. doi:10.1016/j.bmcl.2005.08.040
- Acharya, B. N.; Saraswat, D.; Tiwari, M.; Shrivastava, A. K.; Ghorpade, R.; Bapna, S.; Kaushik, M. P. *Eur. J. Med. Chem.* **2010**, *45*, 430–438. doi:10.1016/j.ejmech.2009.10.023
- Ciupa, A.; De Bank, P. A.; Mahon, M. F.; Wood, P. J.; Caggiano, L. *Med. Chem. Commun.* **2013**, *4*, 956–961. doi:10.1039/c3md00077j
- Nepali, K.; Singh, G.; Turan, A.; Agarwal, A.; Sapra, S.; Kumar, R.; Banerjee, U. C.; Verma, P. K.; Satti, N. K.; Gupta, M. K.; Suri, O. P.; Dhar, K. L. *Bioorg. Med. Chem.* **2011**, *19*, 1950–1958. doi:10.1016/j.bmc.2011.01.058
- Machado, P.; Rosa, F. A.; Rossatto, M.; da S. Sant'Anna, G.; Sauzem, P. D.; Siqueira da Silva, R. M.; Rubin, M. A.; Ferreira, J.; Bonacorso, H. G.; Zanatta, N.; Martins, M. A. P. *ARKIVOC* **2007**, No. xvi, 281–297. doi:10.3998/ark.5550190.0008.g28

25. Sauzem, P. D.; Machado, P.; Rubin, M. A.; da S. Sant'Anna, G.; Faber, H. B.; de Souza, A. H.; Mello, C. F.; Beck, P.; Burrow, R. A.; Bonacorso, H. G.; Zanatta, N.; Martins, M. A. P. *Eur. J. Med. Chem.* **2008**, *43*, 1237–1247. doi:10.1016/j.ejmech.2007.07.018
26. Holla, B. S.; Udupa, K. V.; Sridhar, K. R. *Bull. Chem. Soc. Jpn.* **1989**, *62*, 3409–3411. doi:10.1246/bcsj.62.3409
27. Waldo, J. P.; Mehta, S.; Larock, R. C. *J. Org. Chem.* **2008**, *73*, 6666–6670. doi:10.1021/jo800789p
28. Joshi, K. C.; Bohra, R.; Joshi, B. S. *Inorg. Chem.* **1992**, *31*, 598–603. doi:10.1021/ic00030a014
29. Kumar Dey, D.; Lycka, A.; Mitra, S.; Rosair, G. M. *J. Organomet. Chem.* **2004**, *689*, 88–95. doi:10.1016/j.jorganchem.2003.09.035
30. de Sousa, G. F.; Garcia, E.; Gatto, C. C.; Resck, I. S.; Deflon, V. M.; Ardisson, J. D. *J. Mol. Struct.* **2010**, *981*, 46–53. doi:10.1016/j.molstruc.2010.07.023
31. Someya, C. I.; Inoue, S.; Irran, E.; Krackl, S.; Enthaler, S. *Eur. J. Inorg. Chem.* **2011**, 2691–2697. doi:10.1002/ejic.201100248
32. Sevenard, D. V.; Khomutov, O. G.; Kodess, M. I.; Pashkevich, K. I.; Loop, I.; Lork, E.; Rösenthaller, G.-V. *Can. J. Chem.* **2001**, *79*, 183–194. doi:10.1139/v01-003
33. Zelenin, K. N.; Tugusheva, A. R.; Yakimovitch, S. I.; Alekseev, V. V.; Zerova, E. V. *Chem. Heterocycl. Compd.* **2002**, *38*, 668–676. doi:10.1023/a:1019909117505
34. Zelenin, K. N.; Alekseyev, V. V.; Tygysheva, A. R.; Yakimovitch, S. I. *Tetrahedron* **1995**, *51*, 11251–11256. doi:10.1016/0040-4020(95)00672-u
35. Rateb, L.; Azmy, B.; Nashed, M. A.; Iskander, M. F. *Z. Naturforsch., B: Anorg. Chem., Org. Chem.* **1978**, *33*, 1527–1534. doi:10.1515/znb-1978-1233
36. Bonacorso, H. G.; Wiethan, C. W.; Porte, L. M. F.; Moraes, M. C.; Navarini, J.; Belo, C. R.; Luz, F. M.; Zanatta, N.; Martins, M. A. P. *ARKIVOC* **2013**, No. iv, 291–305. doi:10.3998/ark.5550190.p008.164
37. Martins, M. A. P.; Moreira, D. N.; Frizzo, C. P.; Longhi, K.; Zanatta, N.; Bonacorso, H. G. *J. Braz. Chem. Soc.* **2008**, *19*, 1361–1368. doi:10.1590/s0103-50532008000700019
38. Moreira, D. N.; Frizzo, C. P.; Longhi, K.; Zanatta, N.; Bonacorso, H. G.; Martins, M. A. P. *Monatsh. Chem.* **2008**, *139*, 1049–1054. doi:10.1007/s00706-008-0874-8
39. Martins, M. A. P.; Beck, P.; Machado, P.; Brondani, S.; Moura, S.; Zanatta, N.; Bonacorso, H. G.; Flores, A. F. C. *J. Braz. Chem. Soc.* **2006**, *17*, 408–411. doi:10.1590/s0103-50532006000200027
40. Buriol, L.; Frizzo, C. P.; Marzari, M. R. B.; Moreira, D. N.; Prola, L. D. T.; Zanatta, N.; Bonacorso, H. G.; Martins, M. A. P. *J. Braz. Chem. Soc.* **2010**, *21*, 1037–1044. doi:10.1590/s0103-50532010000600012
41. Lessing, T.; Müller, T. J. J. *Appl. Sci.* **2015**, *5*, 1803–1836. doi:10.3390/app5041803
42. D'Souza, D. M.; Müller, T. J. J. *Chem. Soc. Rev.* **2007**, *36*, 1095–1108. doi:10.1039/b608235c
43. Müller, T. J. J. *Drug Discovery Today: Technol.* **2018**, *29*, 19–26. doi:10.1016/j.ddtec.2018.06.003
44. Gers-Panther, C. F.; Müller, T. J. J. Multicomponent Synthesis of Heterocycles Initiated by Catalytic Generation of Ynones and Ynediones. In *Advances in Heterocyclic Chemistry*; Scriven, E. F. V.; Ramsden, C. A., Eds.; Academic Press, 2016; Vol. 120, pp 67–98. doi:10.1016/bs.aihch.2016.04.007
45. Müller, T. J. J. *Top. Heterocycl. Chem.* **2010**, *25*, 25–94. doi:10.1007/7081\_2010\_43
46. Willy, B.; Müller, T. J. J. *Curr. Org. Chem.* **2009**, *13*, 1777–1790. doi:10.2174/138527209789630479
47. Willy, B.; Müller, T. J. J. *ARKIVOC* **2008**, No. i, 195–208. doi:10.3998/ark.5550190.0009.107
48. Merkul, E.; Dohe, J.; Gers, C.; Rominger, F.; Müller, T. J. J. *Angew. Chem., Int. Ed.* **2011**, *50*, 2966–2969. doi:10.1002/anie.201007194
49. Boersch, C.; Merkul, E.; Müller, T. J. J. *Angew. Chem., Int. Ed.* **2011**, *50*, 10448–10452. doi:10.1002/anie.201103296
50. Merkt, F. K.; Höwedes, S. P.; Gers-Panther, C. F.; Gruber, I.; Janiak, C.; Müller, T. J. J. *Chem. – Eur. J.* **2018**, *24*, 8114–8125. doi:10.1002/chem.201800079
51. Gers-Panther, C. F.; Fischer, H.; Nordmann, J.; Seiler, T.; Behnke, T.; Würth, C.; Frank, W.; Resch-Genger, U.; Müller, T. J. J. *J. Org. Chem.* **2017**, *82*, 567–578. doi:10.1021/acs.joc.6b02581
52. Gers, C. F.; Nordmann, J.; Kumru, C.; Frank, W.; Müller, T. J. J. *J. Org. Chem.* **2014**, *79*, 3296–3310. doi:10.1021/jo4025978
53. CCDC 1902138 (**5a**), CCDC 1906570 (**5r**), and CCDC 1906571 (**6a**) contain the supplementary crystallographic data (excluding structure factors) for this paper. These data are provided free of charge by The Cambridge Crystallographic Data Centre.

## License and Terms

This is an Open Access article under the terms of the Creative Commons Attribution License (<http://creativecommons.org/licenses/by/4.0>). Please note that the reuse, redistribution and reproduction in particular requires that the authors and source are credited.

The license is subject to the *Beilstein Journal of Organic Chemistry* terms and conditions: (<https://www.beilstein-journals.org/bjoc>)

The definitive version of this article is the electronic one which can be found at: [doi:10.3762/bjoc.15.136](https://doi.org/10.3762/bjoc.15.136)



# Efficiency $Eff_{syn}$ of complex syntheses as multicomponent reactions, its algorithm and calculations based on concrete criteria

Heiner Eckert

## Full Research Paper

Open Access

Address:  
Technical University of Munich, Department of Chemistry,  
Lichtenbergstr. 4, D-85747 Garching, Germany

Email:  
Heiner Eckert - eckert@tum.de

Keywords:  
efficiency; efficiency algorithm; multicomponent; overall yield;  
synthesis algorithm; synthesis efficiency; synthesis evaluation

*Beilstein J. Org. Chem.* **2019**, *15*, 1425–1433.  
doi:10.3762/bjoc.15.142

Received: 24 February 2019

Accepted: 11 June 2019

Published: 27 June 2019

This article is part of the thematic issue "Multicomponent reactions III".

Guest Editor: T. J. J. Müller

© 2019 Eckert; licensee Beilstein-Institut.  
License and terms: see end of document.

## Abstract

A synthesis efficiency algorithm, which must be based on concrete and reliable criteria, is essential for the evaluation and control of complex chemical synthesis, notably multicomponent reactions (MCRs). An algorithm has been developed to precisely evaluate even highly complex syntheses with regards to their synthesis efficiency  $Eff_{syn}$  as a tool for strict compliance with green chemistry requirements, and for economic progress. The mathematical operations are highly suitable for electronic data processing (EDP). This algorithm is also suitable as a basis for fair cost assessment of complex chemical syntheses.

## Introduction

The ongoing upheavals in the sectors of information technology, energy and electromobility, which are in some cases extremely competitive, mean that ecological and economical aspects of chemistry, as applicable to humans, are increasingly being focused on during this socio-economic transformation. Comprehensive efforts are being undertaken in this field, including in large workshops, e.g., [1].

The efficiency of synthesis forms the core for the evaluation of innovations within synthesis chemistry [2-6] and is the indispensable requirement for a radical simplification of chemical synthesis [3]. Concrete and reliable criteria must be available for this purpose, criteria that can be easily determined and

measured, and which can also form the basis for an algorithm. The standard evaluation of a chemical synthesis is traditionally based on the overall yield  $y_{oa}$ . This is the product of all sequential synthesis steps  $y_n$  (Equation 1).

$$y_{oa} = \prod_{n=1}^N y_n, (n = 1, 2, \text{etc}) \quad (1)$$

An extreme example for the impact of the overall yield is the tropinone synthesis by Willstätter ( $y_{oa} = 0.75\%$ ) [7,8] compared to the Robinson–Schöpf synthesis ( $y_{oa} = 90\%$ ) [9,10] using a double Mannich reaction, a multicomponent reaction

(MCR) [11–13]. The Mannich-3CR is therefore 120 times better than the Willstätter synthesis.

### Criterion overall yield $y_{oa}$

This  $y_{oa}$  directly influences the variable costs for the starting and other materials in each synthesis, but not most other (fixed) costs.

### Criterion synthesis step number $n$

Such costs are significant and manifold, deriving from direct costs such as fixed employee and laboratory costs, laboratory rental and maintenance costs, operating costs, i.e., power, water, (gas), inert gas and disposal costs. Standard laboratory activities that are repetitive, such as reactor configuration, filling, reaction monitoring, draining, work-up, preparation of reaction mixture and product isolation, product purification (distillation, recrystallisation, chromatography) and product analysis apply to all synthesis steps. All these costs are similar for each synthesis step  $n$  and can be said to be constant in the first approximation in cumulo. This provides a second concrete criterion, the synthesis step  $n$ , which also encompasses and quantifies two factors – “waste prevention” and “energy efficiency” – as requirements for “green chemistry”.

The efficiency of a synthesis,  $Eff_{syn}$  will be defined in Equation 2. The synthesis step  $n$  in the context of this paper is a practical unit of reactions with supplements that all are run in one pot in one working process without intermediate isolation and purification of the reaction participants. The synthesis step therefore differs somewhat from the normal definition of a reaction step.

$$Eff_{syn} = y_{oa} / N \quad (N = \text{overall number of synthesis steps}) \quad (2)$$

Time influences reactions via their kinetics and is therefore not a primary factor but a soft criterion. This can usually be greatly minimised during cost generation through clever time management of the synthesis planning and can essentially be treated here as a fixed cost.

Table 1 indicates the major impact the synthesis steps  $n$  have on the efficiency  $Eff_{syn}$  of the synthesis. The range of profitable to useful syntheses decreases drastically with increasing synthesis steps  $n$ . The detrimental impact of a greater number of steps  $n$  is shown in the above-mentioned tropinone synthesis by Willstätter ( $y_{oa} = 0.75\%$ ,  $N = 20$ ,  $Eff_{syn} = 0.038\%$  [7,8]), compared with the Robinson–Schöpf synthesis ( $y_{oa} = 90\%$ ,  $N = 1$ ,  $Eff_{syn} = 90\%$  [9,10]). The latter MCR is therefore 2368 times (!) more efficient than the original Willstätter synthesis. Further examples, including the comprehensive synthesis of complex natural substances, can be found in [2,3].

These figures may astound some people, but they are the clear results of an impartial analysis. Limitations need to be determined in order to delineate the scope of a meaningful application area.

Ignoring or omitting the number of steps as an essential criterion is a serious issue, for example, if one simply assumes that 4 reactions with 97% yield each are better than a 4CR with 90% yield. The fact that the outlay (fixed costs) during MCR drop by a massive 75% – compared to the 4 separate reactions – is often ignored. And those 4 separate reactions actually have an overall yield of 88.5%. This behaviour is unfortunately very common, culpably inefficient! The overall yield alone does not encompass such facts and any mathematical treatment needs to bring together all primary criteria.

**Table 1:** Overall yields  $y_{oa}$  and synthesis efficiency  $Eff_{syn}$ .

Overall yields $y_{oa}$ [%] geometric average yields $y_{av}$					Number of steps $n$	Synthesis efficiency $Eff_{syn}$ [%] geometric average yields $y_{av}$				
95	90	80	70	60		95	90	80	70	60
95	90	80	70	60	1	95	90	80	70	60
90	81	64	49	36	2	45	40	32	25	18
86	73	51	34	22	3	29	24	17	11	7.3
81	66	41	24	13	4	20	17	10	6.0	3.0
77	59	33	17	7.8	5	15	12	6.6	3.4	1.6
74	53	26	12	4.7	6	12	8.8	4.3	2.0	0.78
70	48	21	8.2	2.8	7	10	6.9	3.0	1.2	0.40
66	43	17	5.8	1.7	8	8.3	5.4	2.1	0.73	0.21
63	39	13	4.0	1.0	9	7.0	4.3	1.8	4.4	0.11
60	35	11	2.8	0.6	10	6.0	3.5	1.1	0.28	0.06

MCRs have a high material and energy efficiency, and their atom balance is quite outstanding. Product purification is usually simple. All this reduces waste to a minimum. Due to the very weak negative reaction enthalpies, MCRs are also usually safe processes. The shortening of the synthesis through drastic reduction of the number of steps  $n$  leads to a strong waste prevention, which can be quantitatively measured through the synthesis efficiency in Equation 2 (Table 1).

## Results and Discussion

In practice, there are problems with complete calculations of overall yields for complex syntheses, particularly when several precursors (2 or more) need to be included in the calculation, which is almost always the case with MCRs. All such reactions are parallel reactions and do not have any sequential character with respect to each other, instead they are cumulative, whereby

the parallel reaction groups have different numbers of individual reactions  $n$ . The yields  $y_n$  then need to be weighted with these  $m$  values and the arithmetic mean  $y_{am}$  calculated as shown in Equation 3.

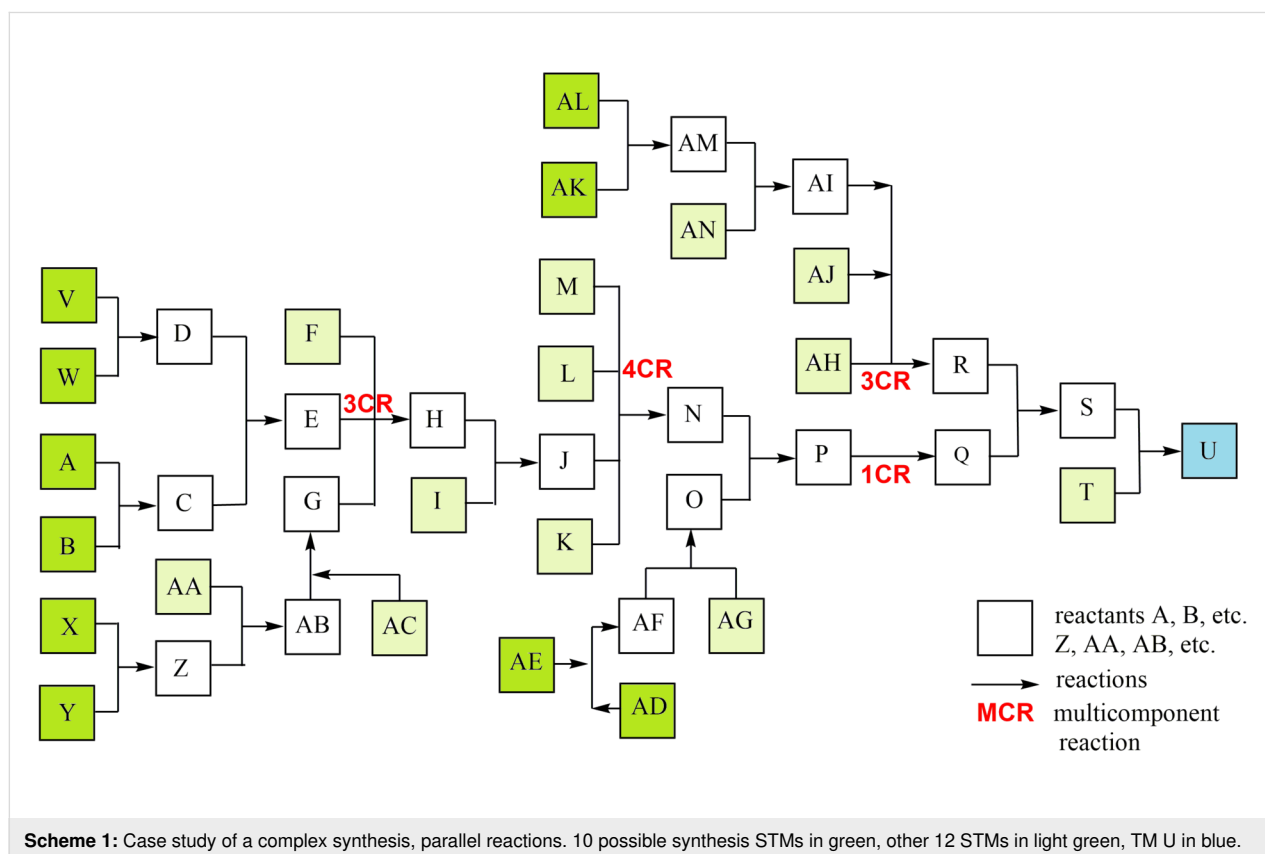
$$y_{am} = \frac{\sum_{j=1}^J (y_j * m_j)}{\sum_{j=1}^J m_j} \quad (3)$$

## Algorithm

If you insert Equation 1 in Equation 3, and then insert this in Equation 2, you will obtain the efficiency algorithm Equation 4. This has already been described in a general manner in [2,3]. The weighting of the parallel reactions results in the precise value  $y_{oa}$ .

$$y_{oa} = \prod_{k=1}^K \left[ \frac{\sum_{j=1}^J \left( \prod_{n=1}^N y_n * m_j \right)}{\sum_{j=1}^J m_j} \right] \quad (4)$$

$K$  = number of main reaction steps  
 $J$  = number of branches  
 $N$  = number of synthesis steps  
 $m$  = number of weightings  
 $y$  = weighted yields



The algorithm is broad in scope and can be used in many ways as required through the introduction of constants in the variables  $c_1$ ,  $c_2$  and invariable  $C$ . This permits the inclusion of soft criteria, such as suitable resources, time (see discussion above) and process control, in the cost analysis of complex syntheses (Equation 5).

$$\text{Synthesis costs} = c_1 * N / c_2 * y_{oa} + C \quad (5)$$

An App based on this algorithm can offer an effective way to obtain a rapid overview of the total or partial synthesis. It can be used to evaluate and even control the synthesis from various aspects, including how it is affected by soft criteria.

## Case study

All listed and possible constellations of reactions and reaction groups in a complex synthesis are shown in a flow diagram (Scheme 1) and are presented in a detailed case study; the data were inserted into the general efficiency algorithm [2,3]. Although publications usually only show the synthesis path with the most spectacular molecules, such as the target molecule (TM), the total synthesis with all reactions is essential for production. The quantity of potential start molecule (STM) sets also rises strongly in complex syntheses. The example shows 5 STM sets (consisting of 10 STMs) with which the synthesis can be started, as well as 12 other STMs.

To have a better overview in this study (Scheme 1), reactions are ordered to a main reaction set including two MCRs (reactants A–T, TM U), connected with 4 parallel reaction sets including a 3CR (Scheme 2).

## Overall yield $y_{oa}$ and efficiency $Eff_{syn}$ calculation of J in case study

As a practical exercise, random numbers were added to the part A–J with both parallel reactions V–D and X–G in Scheme 3, and the overall yield  $y_{oa}$  was then calculated incrementally with the algorithm in Equation 4. Expediently, a main reaction (set-1) to which the parallel reactions are linked (set-2, set-3) is set up. The weighted arithmetical mean of the yields for each reaction set is formed at the connection forms. The overall yield  $y_{oa}$  of the total synthesis is determined through the sequential operation of the main reaction sets. The latter can be determined using the following calculation method.

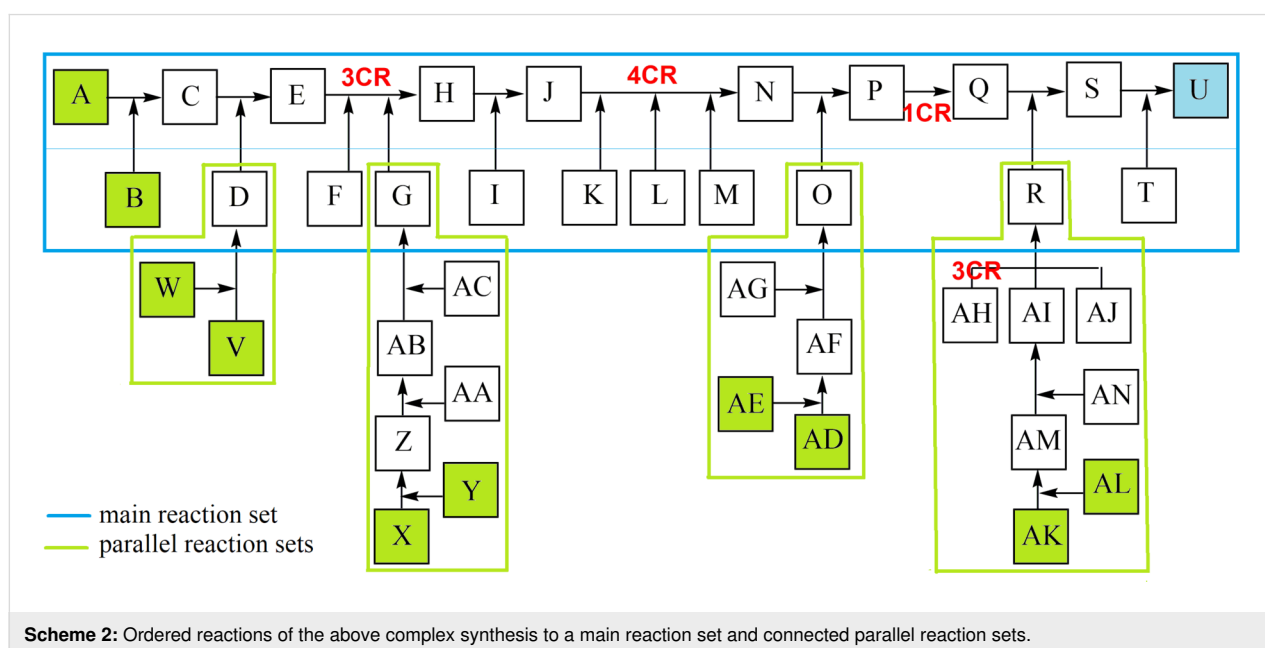
## Calculation method

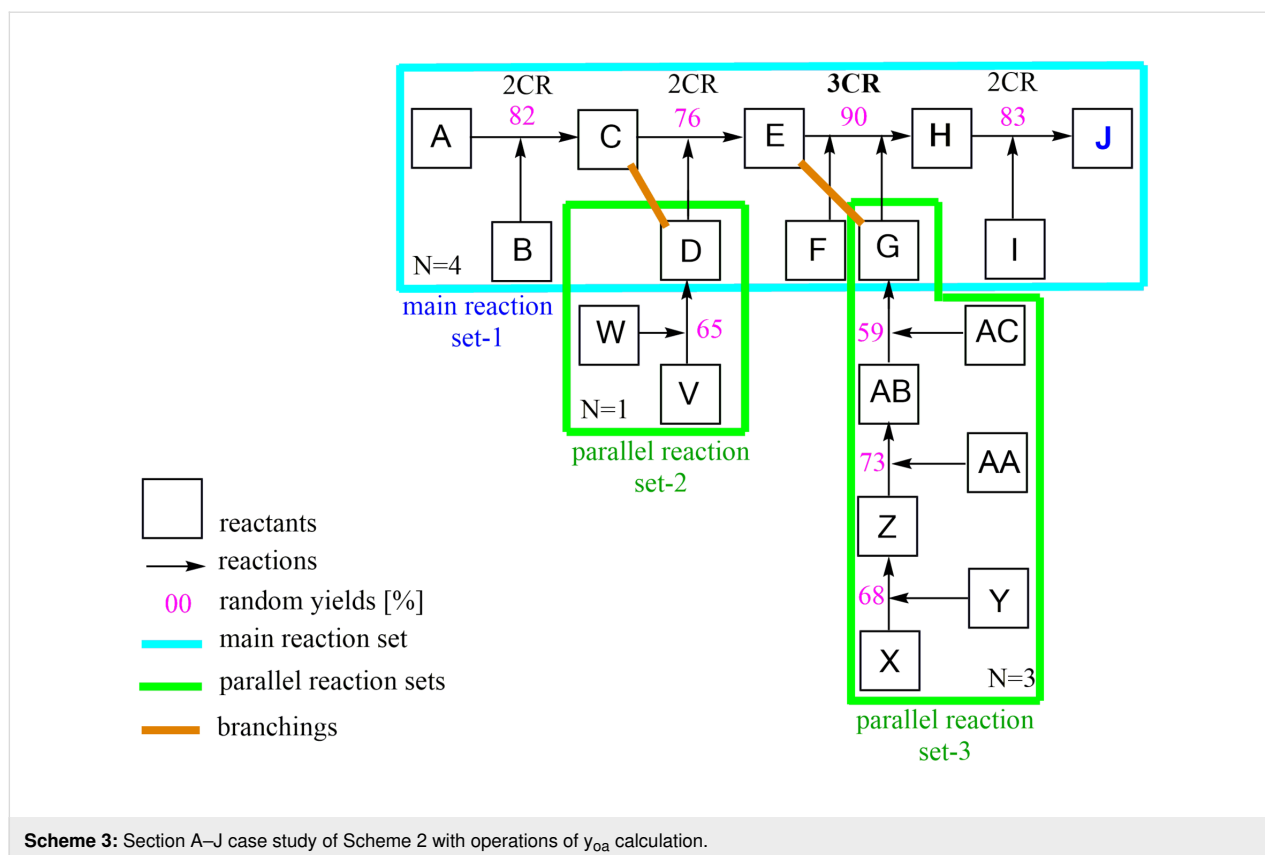
Split the main reaction set-1 at the connection points with the parallel reactions into set-1, set-2, set-3, then use  $\Sigma(\Pi y_n)_j$  to calculate the weighted mean yield values for the two branches C, D and E, G. The latter values, together with the values from  $\Pi[\Sigma(\Pi y_n)_j]_k$ , deliver the overall yield  $y_{oa}$  of the total synthesis according to Equations 6–8.

Parallel reactions set-2 to main reaction position (C), operation  $\Sigma(\Pi y_n)_j$

$$\begin{aligned} y(C, D) &= 1/2 * [y(A-C) * 1 + y(V-D) * 1] \\ &= 1/2 * [0.82 * 1 + 0.65 * 1] \\ &= 1/2 * 1.47 = 0.735 \end{aligned} \quad (6)$$

Parallel reactions set-3 to main reaction position (E), operation  $\Sigma(\Pi y_n)_j$





$$\begin{aligned}
 y(E, G) &= 1/4 * [y(C - E) * 1 + y(X - G) * 3] \\
 &= 1/4 * [0.76 * 1 + (0.68 * 0.73 * 0.59) * 3] \quad (7) \\
 &= 1/4 * [0.76 + 0.87] = 0.41
 \end{aligned}$$

Sequential main reactions set-1, operation  $\Pi[\Sigma(\Pi y_n)]_k$

$$\begin{aligned}
 y(A - J) &= y[C, D] * (E, G) * (E - J) \\
 &= 0.735 * 0.41 * 0.90 * 0.83 \quad (8) \\
 y_{oa} &= 0.23 \text{ (22.5\%)}
 \end{aligned}$$

This synthesis consists of  $n = 8$  synthesis steps, so the synthesis efficiency is

$$Eff_{syn} = y_{oa} / N = 0.23 / 8 = 0.028 \text{ (2.8\%)}$$

### Modification of the calculation execution

Most chemists look exclusively at the interesting target molecule (TM) of a synthesis and only follow that path from STM to TM, while blanking out everything else. The second method for calculating  $y_{oa}$  in complex syntheses is probably easier in this case. Here, the yield  $y(A-J)$  of the sequential main reaction set-1 is calculated (Equation 9) and added to the branches with the parallel reaction modification factors  $mf$ . This is equivalent

to the quotients from the dividends C, D (from Equation 6) or E, G (from Equation 7) and the divisors A–C or E–G (Equations 10 and 11). The result from Equation 9 is multiplied with both modification factors  $mf$  to obtain the overall yield  $y_{oa}$  (Equation 12).

$$y(A - J) = 0.82 * 0.76 * 0.9 * 0.83 = 0.466 \quad (9)$$

$$mf(C, D) = 0.735 / 0.82 = 0.896 \quad (10)$$

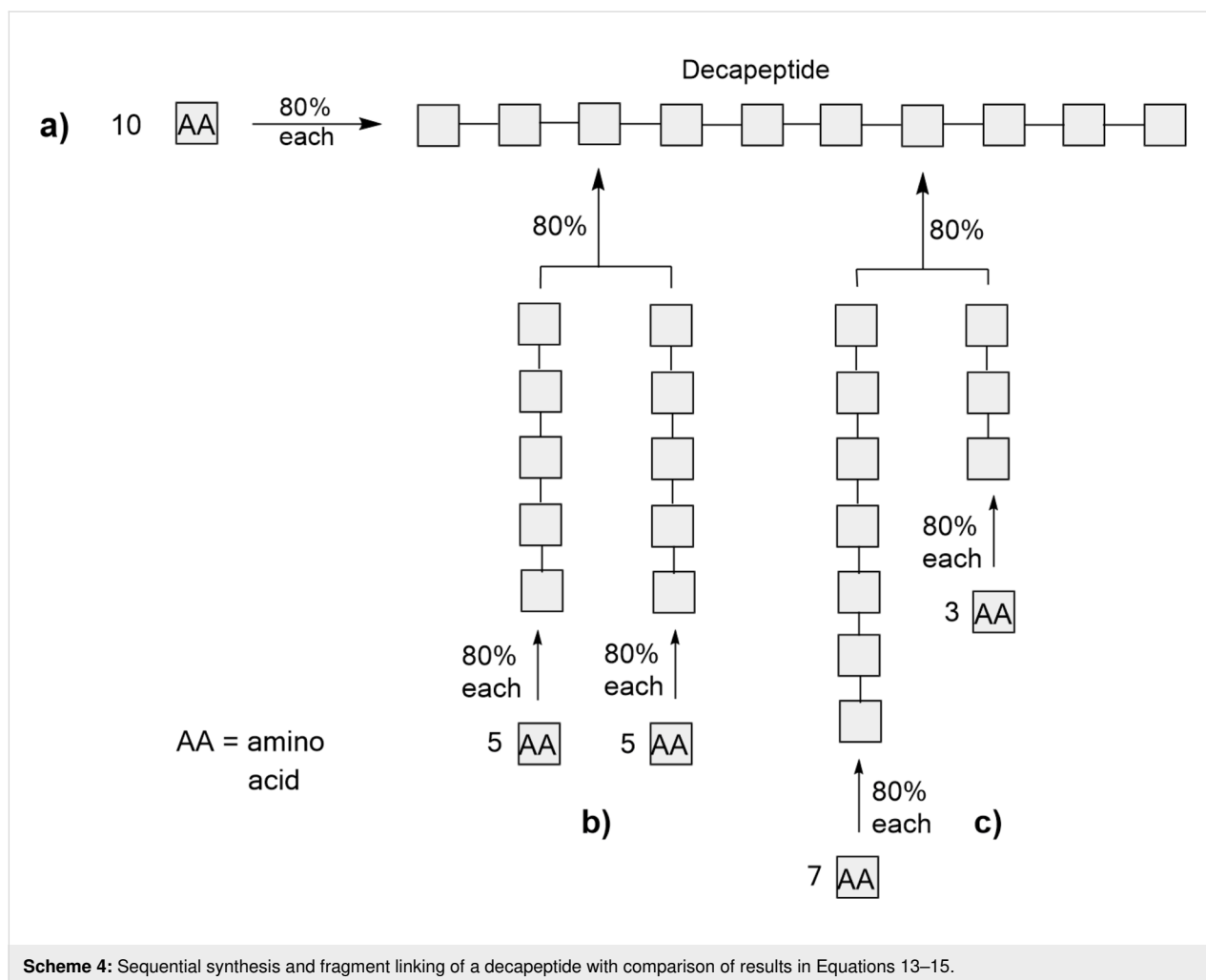
$$mf(E, G) = 0.41 / 0.76 = 0.539 \quad (11)$$

$$\begin{aligned}
 y_{oa} &= y(A - J) * mf(C, D) * mf(E, G) \\
 y_{oa} &= 0.466 * 0.896 * 0.539 = 0.23 \text{ (22.5\%)} \quad (12)
 \end{aligned}$$

Some useful strategic and practical applications demonstrate the enormous influence of branching on the overall yield  $y_{oa}$  and synthesis efficiency  $Eff_{syn}$ .

### Fragment strategy: fragment linking in peptides synthesis

In synthetic peptide chemistry, amino acids are sequentially built up to form long oligo/polypeptides. For reasons of trans-



parency, we have assumed the same yield of 80% in each step during the synthesis of a decapeptide in order to clearly indicate the effect of the branching (Scheme 4).

Three cases are discussed here:

1. sequential linking of the 10 amino acids (Scheme 4a);
2. sequential synthesis of two pentapeptides and the subsequent linking to form a linear decapeptide (Scheme 4b);
3. sequential synthesis of two non-identical peptides (1 heptapeptide and 1 tripeptide) and their linking to form a linear decapeptide (Scheme 4c);

### Calculation by means of the algorithm

$$\text{a) } y_{oa} = 0.8^9 = 0.13 \text{ (13\%)} \quad (13)$$

$$\text{b) } y_{oa} = [(0.8^4 + 0.8^4) / 2] * 0.8 = 0.41 * 0.8 = 0.33 \text{ (33\%)} \quad (14)$$

$$\begin{aligned} \text{c) } y_{oa} &= [(0.8^6 * 6 + 0.8^2 * 2) / 8] * 0.8 \\ &= [(0.26 * 6 + 0.64 * 2) / 8] * 0.8 \\ &= [(1.56 + 1.28) / 8] * 0.8 \\ &= 0.355 * 0.8 = 0.284 \text{ (28.4\%)} \end{aligned} \quad (15)$$

The results are impressive. A up to 2.5-fold yield can be achieved depending on the configuration of the fragment linking, and the algorithm delivers rapid results. The number of steps is, however, only conditionally reduced (with identical steps) and this must be taken into consideration when calculating the synthesis efficiency  $Eff_{syn}$ . The fragment strategy can of course be applied without limitations to other syntheses of this type.

### MCR Strategy: Ugi-4CR in ecteinascidin-743 total synthesis

As described above, yields can be significantly increased by using the fragment strategy. However, the fragment strategy is limited to 2 components, while an MCR provides multiple

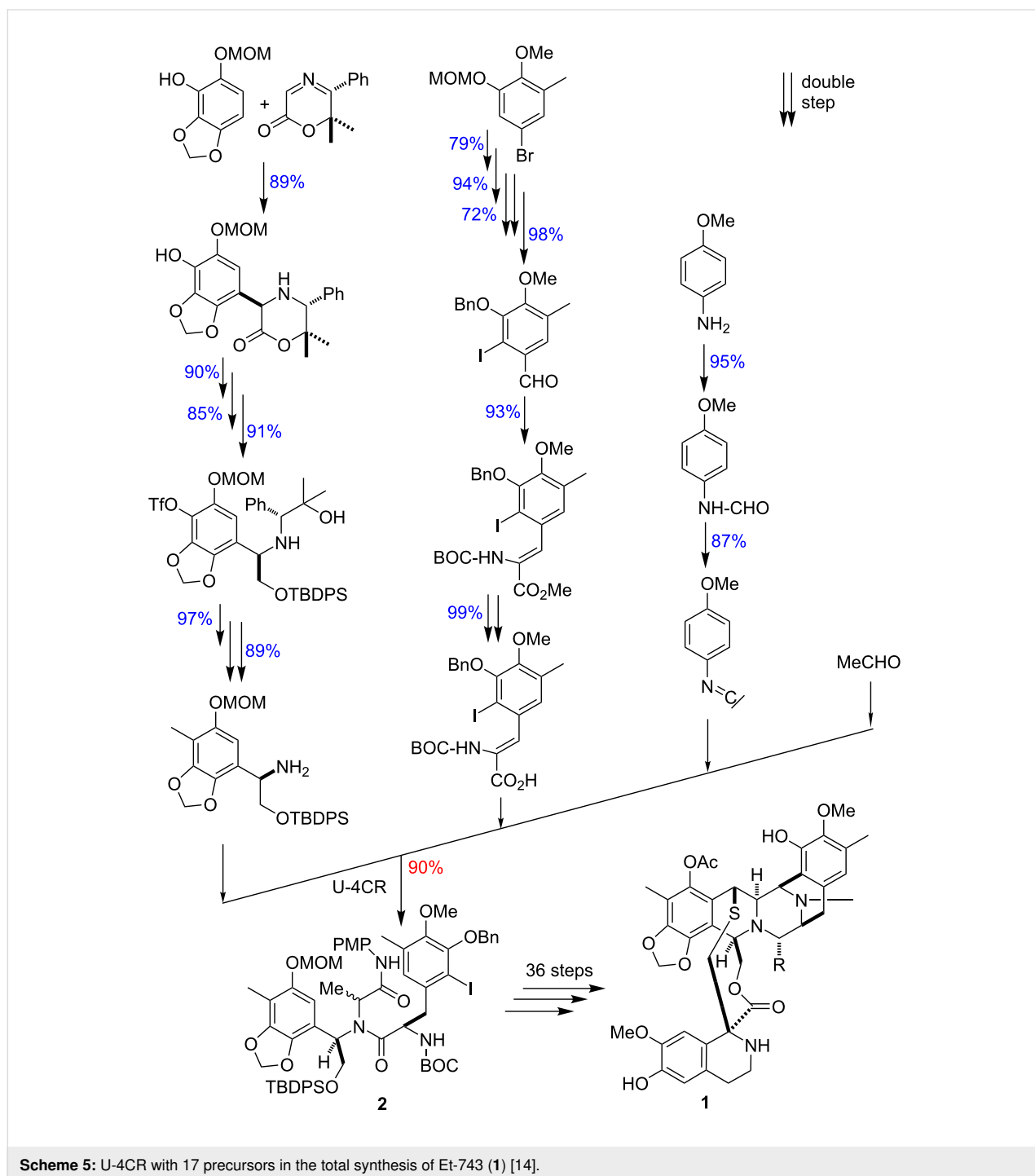
components for linking, and also generates its own structure which is capable of extensions like the domino reaction types [5].

An Ugi reaction is used in the total synthesis of the extremely potent antitumor agent ecteinascidin-743 (Et-743, **1**) by Fukuyama to form a large part of the skeleton **2** (Scheme 5). All data for the U-4CR are available in the literature [14]. The pre-

cursors of the Ugi reaction consist of 3 reaction chains of 6, 6 and 2 links, respectively.

### Calculation by means of the algorithm

The calculation of the overall yield  $y_{oa}$  of **2** is based on the data basis for the total synthesis of ecteinascidin-743 found in the literature [14], and the data for 4-methoxyphenylisocyanide is provided from the author, referred to Equations 16–20.



$$0.89 * 0.9 * 0.85 * 0.91 * 0.97 * 0.89 = 0.535 \quad (16)$$

$$0.79 * 0.94 * 0.72 * 0.98 * 0.93 * 0.99 = 0.482 \quad (17)$$

$$0.95 * 0.87 = 0.827 \quad (18)$$

$$(0.535 * 6 + 0.482 * 6 + 0.827 * 2) / 14 = 7.76 / 14 = 0.554 \quad (19)$$

$$y_{oa} = 0.554 * 0.9 = 0.499 \text{ (50\%)} \quad (20)$$

An outstanding result is shown for U-4CR, including the  $N = 14$  (from real 17; three are double steps) precursors forming **2** with 50% overall yield. Synthesis efficiency is  $Eff_{syn} = 2.9\%$ , due to the high step number of 17 (real number of precursors). The same synthesis in linear architecture does not exist. A fictive comparison with the same dataset in a completely sequential reaction sequence results in a fictive yield of **2**  $y_{oa}(\text{fictive}) = 0.192$  (19%). The significant difference is due to the MCR itself and primarily the linked parallel reactions of the 3 precursors, as can be clearly seen in Scheme 5. These results favour the use of the MCR strategy with the Ugi reaction and provide an increase in yield by 2.6 times that of a linear solution.

### MCR strategy: novel MCR as key step in total synthesis of (+)-20S-camptothecin

Another typical example for the simplification of a complex chemical synthesis [2,3] is the total synthesis of the extremely potent antitumor agent (+)-20S-camptothecin (**3**), which has been a highly effective agent for decades now. This total synthesis by Tietze uses a 4CR, specifically generated for this reaction from an aldehyde, meldrum's acid, enol ether and methanol, as a key step in the synthesis to **4** (Scheme 6) [15]. This step-saving strategy for generating novel MCRs is a fast track towards the ubiquitous use of MCRs in complex syntheses. This algorithm (Equation 4) is an essential tool for the rational evaluation and synthesis control of MCRs.

## Conclusion

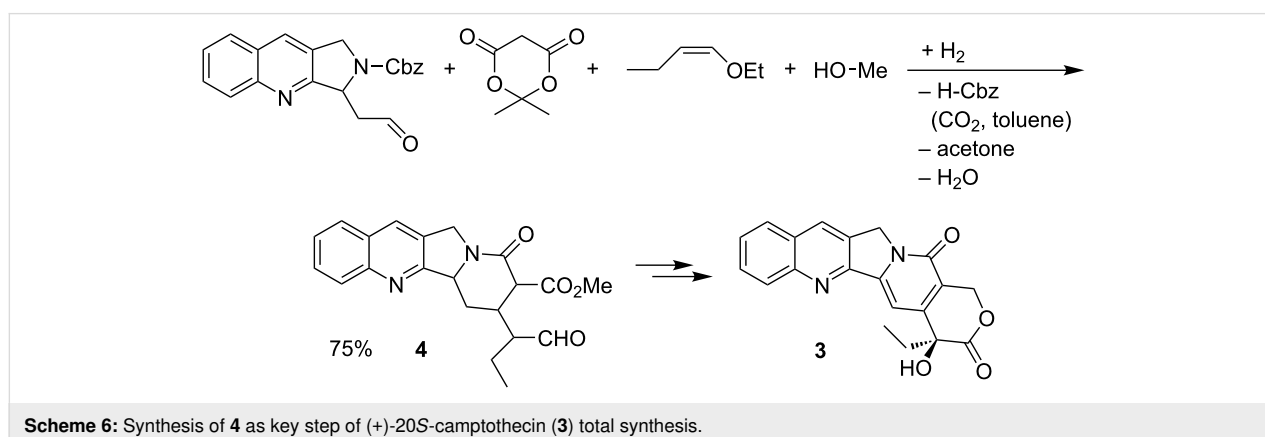
The general efficiency algorithm [2,3], and the calculation methods (Equations 3–20) developed from that algorithm, can be used to precisely evaluate even highly complex syntheses and quantitatively compare them with alternative syntheses with regards to their synthesis efficiency  $Eff_{syn}$ . The mathematical operations are highly suitable for electronic data processing (EDP), as is the algorithm itself. Due to the concrete criteria, this algorithm is also suitable as a basis for fair cost assessment of complex chemical syntheses. Fragment linking reactions, and an ecteinascidin-743 total syntheses including an Ugi reaction, as well as a 20S-camptothecin total synthesis based on a 4CR specifically generated for this purpose, were discussed. This demonstrates the high efficiency of the MCR application and its intrinsic suitability for green chemistry.

## ORCID® iDs

Heiner Eckert - <https://orcid.org/0000-0003-2399-2703>

## References

- <http://low-carbon-urban-development-germany-china.org/wp-content/uploads/2016/04/Weber-Sites-Consulting-Energy-Efficient-Technologies-in-Chemical-Industry-DE.pdf>
- Eckert, H. *Molecules* **2017**, *22*, 349. doi:10.3390/molecules22030349
- Eckert, H., Ed. *Radical and Concerted Simplification of Chemical Synthesis*; Wolff-Verlag: Berlin, Germany, 2017.
- Eckert, H. Radical simplification of chemical synthesis by MCRs Strategies. In *Book of abstract, MCR-2018*, Aug 26–31, 2018; 7th international conference on multicomponent reactions and related chemistry; p 71.
- Tietze, L. F., Ed. *Domino Reactions: Concepts for Efficient Organic Synthesis*; Wiley-VCH: Weinheim, Germany, 2014. doi:10.1002/9783527671304
- Bienaymé, H.; Hulme, C.; Odon, G.; Schmitt, P. *Chem. – Eur. J.* **2000**, *6*, 3321–3329. doi:10.1002/1521-3765(20000915)6:18<3321::aid-chem3321>3.0.co;2-a
- Willstätter, R. *Justus Liebigs Ann. Chem.* **1901**, *317*, 204–265. doi:10.1002/jlac.19013170206



8. Smit, W. A.; Bochkov, A. F.; Caple, R. *Organic Synthesis: The Science behind the Art*; Royal Society of Chemistry: Cambridge, United Kingdom, 1998.
9. Robinson, R. J. *Chem. Soc., Trans.* **1917**, *111*, 762–768.  
doi:10.1039/ct9171100762
10. Schöpf, C. *Angew. Chem.* **1937**, *50*, 779–787.  
doi:10.1002/ange.19370504002
11. Zhu, J.; Bienaymé, H., Eds. *Multicomponent Reactions*; Wiley-VCH: Weinheim, Germany, 2005. doi:10.1002/3527605118
12. Mueller, T. J. J., Ed. *Multicomponent Reactions*; Science of Synthesis, Vol. I + II; Thieme: Stuttgart, Germany, 2014.
13. Huang, Y.; Yazbak, A.; Dömling, A. Multicomponent reactions. In *Green Techniques for Organic Synthesis and Medicinal Chemistry*; Zhang, W.; Cue, B. C., Jr., Eds.; John Wiley & Sons Ltd.: New York, U.S.A.; pp 497–522. doi:10.1002/9780470711828.ch18
14. Endo, A.; Yanagisawa, A.; Abe, M.; Tohma, S.; Kan, T.; Fukuyama, T. *J. Am. Chem. Soc.* **2002**, *124*, 6552–6554. doi:10.1021/ja026216d
15. Tietze, L. F.; Bischoff, M.; Khan, T. A.; Liu, D. *Chem. Heterocycl. Compd.* **2017**, *53*, 434–445.  
doi:10.1007/s10593-017-2070-4

## License and Terms

This is an Open Access article under the terms of the Creative Commons Attribution License (<http://creativecommons.org/licenses/by/4.0>). Please note that the reuse, redistribution and reproduction in particular requires that the authors and source are credited.

The license is subject to the *Beilstein Journal of Organic Chemistry* terms and conditions: (<https://www.beilstein-journals.org/bjoc>)

The definitive version of this article is the electronic one which can be found at:  
[doi:10.3762/bjoc.15.142](https://doi.org/10.3762/bjoc.15.142)



# A novel three-component reaction between isocyanides, alcohols or thiols and elemental sulfur: a mild, catalyst-free approach towards *O*-thiocarbamates and dithiocarbamates

András György Németh, György Miklós Keserű and Péter Ábrányi-Balogh\*

## Full Research Paper

Open Access

### Address:

Hungarian Academy of Sciences, Research Centre for Natural Sciences, Institute of Organic Chemistry, Medicinal Chemistry Research Group, 1519 Budapest, POB 286, Hungary

### Email:

Péter Ábrányi-Balogh\* - abrani-balogh.peter@ttk.mta.hu

\* Corresponding author

### Keywords:

dithiocarbamate; elemental sulfur; multicomponent reaction; one-pot; thiocarbamate

*Beilstein J. Org. Chem.* **2019**, *15*, 1523–1533.

doi:10.3762/bjoc.15.155

Received: 19 March 2019

Accepted: 21 June 2019

Published: 10 July 2019

This article is part of the thematic issue "Multicomponent reactions III".

Guest Editor: T. J. J. Müller

© 2019 Németh et al.; licensee Beilstein-Institut.

License and terms: see end of document.

## Abstract

A new multicomponent reaction has been developed between isocyanides, sulfur and alcohols or thiols under mild reaction conditions to afford *O*-thiocarbamates and dithiocarbamates in moderate to good yields. The one-pot reaction cascade involves the formation of an isothiocyanate intermediate, thus a catalyst-free synthesis of isothiocyanates, as valuable building blocks from isocyanides and sulfur is proposed, as well. The synthetic procedure suits the demand of a modern organic chemist, as it tolerates a wide range of functional groups, it is atom economic and easily scalable.

## Introduction

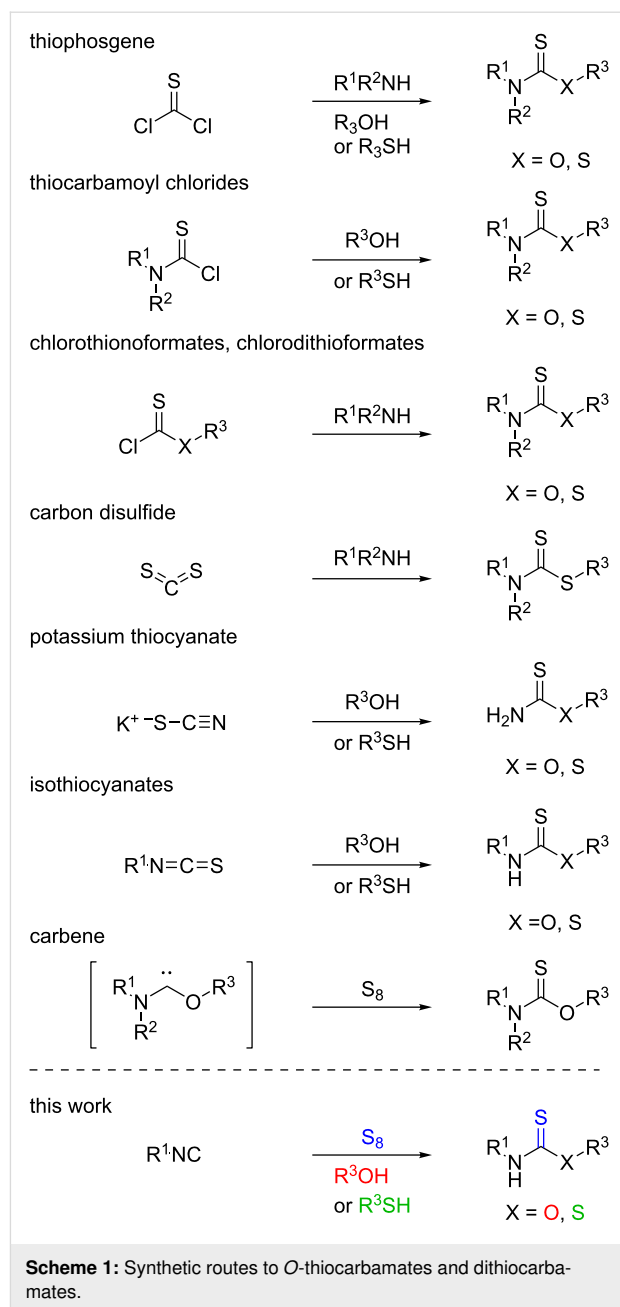
*O*-Thiocarbamates belong to a class of important biologically active molecules, used mainly as fungicides [1-3] in agricultural and pharmaceutical fields. In particular, recently anti-tumor [4], anesthetic [5] and enzyme inhibitory effects were discovered, including HIV-1 reverse transcriptase inhibition activity [6-11]. Moreover, their utilization as highly regio- and stereoselective organocatalysts in specific types of chemical transformations [12-17] was introduced, as well. More recently, *O*-thiocarbamates have been used as H<sub>2</sub>S donors in biological systems [18] and as intermediates in pharmaceutically significant organic syntheses [19,20]. The dithiocarbamate structural

moiety can be found in biologically active molecules widely applied as fungicides, herbicides, pesticides [21-25] and in some cases as enzyme inhibitors [26] or antitumor agents [27]. These species are also used as valuable synthetic intermediates [28] and chemosensors for mercury and silver [29,30].

The general methods for the synthesis of *O*-thiocarbamates and dithiocarbamates traditionally rely on substitution reactions of the corresponding halogenated precursors, including thiophosgene [31-33], thiocarbamoyl chlorides [34-37], chlorothionoformates or chlorodithioformates [38-41] providing the appro-

appropriate thiocarbamate analogues in good yields (Scheme 1). However, these methods suffer from the formation of toxic, malodorous and/or extremely corrosive byproducts generated by the elimination of the halogen atoms. One should note that the application of these halogenated thiocarbonic acid derivatives might be dangerous and require thorough precaution. Considering dithiocarbamates, a number of methods are based on the reaction of amines and the readily available, but toxic and volatile carbon disulfide [42-45]. Greener methods for the synthesis of thiocarbamates and dithiocarbamates have been developed such as the addition of the amine component to potassium thiocyanate [46,47] or isothiocyanate [48-52] showing better atom economy. Nonetheless, only a few examples can be found in the literature starting from thiocyanates, and regarding the isothiocyanates the preparation of the reagent is required as an additional reaction step before.

The synthesis of isothiocyanates generally relies on the reaction between thiophosgene and amines, thus involves the use of a highly toxic reagent with narrow functional group compatibility [53-56]. Various thiocarbonyl transfer reagents have been developed in the last decades to overcome these drawbacks, such as thiocarbonyl-diimidazole or di-2-pyridyl thionocarbonate [57,58]. Decomposition of dithiocarbamate salts or thiocarbamates with various reagents offers a good alternative [59-62] as well, however, this approach first requires the synthesis of the appropriate precursor. Nitrile oxides react with thiourea to afford isothiocyanate and harmless urea [63-65], but one should note that the instability of the nitrile oxides leads to many byproducts, turning this approach less attractive. The synthesis of isothiocyanates starting from isonitriles involves sulfur-containing reagents such as thallium thiocarboxylates or thiols in the presence of radical initiators [66-68]. All the previously reported methods for the synthesis of *O*-thiocarbamates, dithiocarbamates and isothiocyanates start from toxic and/or unstable reagents, generate halogen waste or have narrow functional group tolerance. The bench-stable, environmentally benign, cheap and nontoxic elemental sulfur offers an alternative starting material to integrate sulfur into the product [69]. For a single molecule, Tan and co-workers showed isothiocyanate might be formed from an isocyanide by elemental sulfur in the presence of a base in low yield [70]. In certain cases, sulfur can be trapped by in situ generated carbenes to afford *O*-thiocarbamates [71,72]. Thioureas and *S*-thiocarbamates are also accessible through multicomponent reactions starting from isocyanides and sulfur [73-75]. The cumbersome synthesis of isothiocyanates from isocyanides and sulfur [76] can be enhanced using various catalysts such as selenium, molybdenum, copper, rhodium [77-82] or tellurium [83] providing the isothiocyanates in excellent yields. These approaches on the other hand suffer from the use of heavy metals, toxic chal-



**Scheme 1:** Synthetic routes to *O*-thiocarbamates and dithiocarbamates.

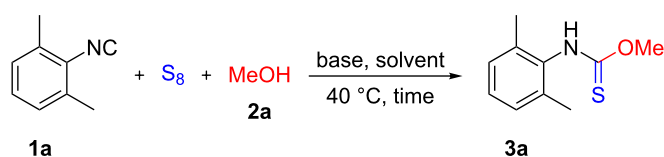
cogens and/or long reaction times. More recently, a novel three-component method has been published starting from readily available amines and sodium bromodifluoroacetate [84], but this synthetic route provides halogenated waste, as well. As a continuation of our interest in the development of multicomponent reactions [85-87] and reactions involving sulfur [88], herein, we describe a novel synthesis of *O*-thiocarbamates and dithiocarbamates via a three-component reaction of elemental sulfur, isocyanides and alcohols or thiols (Scheme 1). Moreover, during the investigation of the reaction mechanism, we have identified and improved a catalyst-free method for the preparation of isothiocyanates.

## Results and Discussion

The model reaction of 2,6-dimethylphenyl isocyanide (**1a**), elemental sulfur ( $S_8$ ) and methanol (**2a**) was employed to screen for the optimal reaction conditions (Table 1). The reactions were followed by TLC and HPLC–MS. Based on preliminary experiments in our laboratory, the reaction was performed in tetrahydrofuran (THF) at 40 °C for 1 h using a 1.5 equiv excess of sodium hydride as the base,  $S_8$  and the alcohol component (Table 1, entry 1) resulting in the desired thiocarbamate **3a** in 58% yield. During the purification procedure, the change of the stationary phase for the column chromatography from aluminium oxide to silica, resulted in an increased yield of 72% (Table 1, entry 2). After the optimization of the purification process, the excess of the reagents and the role of the base were studied. Increasing the molar excess of all reagents to 2 equiv provided **3a** in 91% yield (Table 1, entry 3), however, the yield was decreased by the use of a larger excess (Table 1, entry 4). Reducing the amount of the reagents was not helpful (Table 1,

entry 5), and one can see that 2.5 equiv of sulfur and methanol did not increase the yields either (Table 1, entry 6). A longer reaction time (2 h), however, enhanced the product yield from 72% (Table 1, entry 2) to 84% (Table 1, entry 7). Thus we have combined this reaction time with the elevated molar excess of the reagents resulting in thiocarbamate **3a** in 94% yield (Table 1, entry 8). The advantageous effect of heating was supported by the decreased yield (72%) obtained when performing the reaction at ambient temperature (Table 1, entry 9). Next, the effect of different solvents was investigated, showing that acetonitrile (MeCN) and 2-methyltetrahydrofuran (MeTHF) proved to be suitable alternatives to THF (Table 1, entries 13 and 15) that might be advantageous considering the wide application of these solvents in industrial production [89,90]. On the contrary, the use of dioxane, methyl *tert*-butyl ether (MTBE), toluene or dichloromethane (DCM) was unfavorable, providing the thiocarbamate in 67%, 29%, 12% and 30% yields, respectively (Table 1, entries 10, 11, 12, and 14). Notably, in the lack

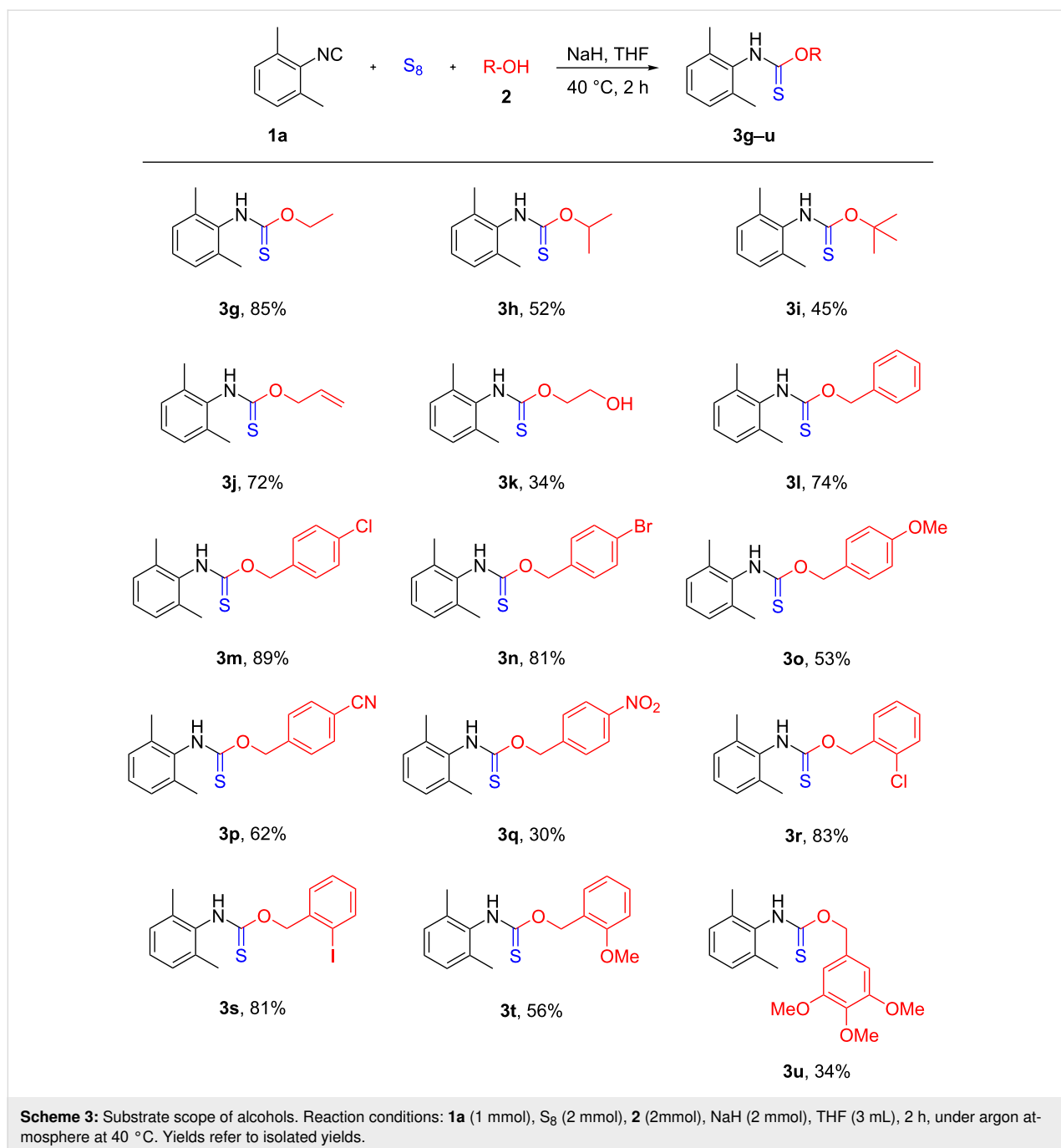
**Table 1:** Optimization of the reaction conditions for the synthesis of *O*-thiocarbamates.



Entry	Solvent	Base	Time [h]	Molar excess <b>2a</b> / $S_8$ /base	Yield [%] <sup>a,b</sup>
1	NaH	THF	1	1.5:1.5:1.5	58 <sup>c</sup>
2	NaH	THF	1	1.5:1.5:1.5	72
3	NaH	THF	1	2:2:2	91
4	NaH	THF	1	2.5:2.5:2.5	80 <sup>d</sup>
5	NaH	THF	1	1.5:1.5:2	61
6	NaH	THF	1	2.5:2.5:2	88
7	NaH	THF	2	1.5:1.5:1.5	84
<b>8</b>	<b>NaH</b>	<b>THF</b>	<b>2</b>	<b>2:2:2</b>	<b>94<sup>d</sup></b>
9	NaH	THF	2	2:2:2	72 <sup>e</sup>
10	NaH	dioxane	2	2:2:2	67
11	NaH	MTBE	2	2:2:2	29
12	NaH	toluene	2	2:2:2	12 <sup>d</sup>
13	NaH	MeCN	2	2:2:2	92 <sup>d</sup>
14	NaH	DCM	2	2:2:2	30
15	NaH	MeTHF	2	2:2:2	87 <sup>d</sup>
16	NaH	THF	2	2:2:2	72 <sup>f</sup>
17	Cs <sub>2</sub> CO <sub>3</sub>	THF	2	2:2:2	0 (26) <sup>g</sup>
18	DIPEA	THF	2	2:2:2	0 (30) <sup>g</sup>
19	DBU	THF	2	2:2:2	39
20	NaOEt	THF	2	2:2:2	0 (53) <sup>g</sup>
21	–	THF	2	2:2:2	n.r.

<sup>a</sup>Reaction conditions: **1a** (1 mmol),  $S_8$ , **2a**, base, solvent (3 mL), time, under argon atmosphere at 40 °C. <sup>b</sup>Isolated yields. <sup>c</sup>Flash column chromatography performed on aluminium oxide as stationary phase. <sup>d</sup>Average of two runs. <sup>e</sup>Room temperature. <sup>f</sup>Lack of inert atmosphere. <sup>g</sup>Yield of isothiocyanate intermediate. n.r. = no reaction.



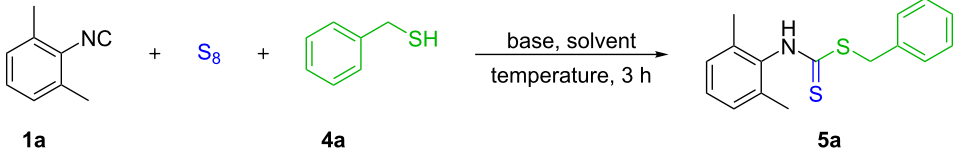


point. However, the thiocarbamate **3c** happened to be unstable and started to decompose after work-up. Therefore, an HPLC–MS spectrum of the reaction mixture after completion of the reaction and an HRMS of the crude product are attached in Supporting Information File 1.

Several experiments were performed to discover the reaction conditions that enable the synthesis of *O*-aryl thiocarbamates. Initially, DBU was used in refluxing dioxane, as this base was shown to provide the appropriate aliphatic *O*-thiocarbamate.

However, in this case only the isothiocyanate intermediate was obtained. Then, trimethylamine was applied in refluxing MeCN [95] or sodium hydroxide in dimethyl sulfoxide (DMSO) at 70 °C. In both cases only the isothiocyanate intermediate and phenol were observed by HPLC–MS but no formation of the desired product.

Then we turned to the synthesis of dithiocarbamate **5a** under the standard reaction conditions, but only the isothiocyanate intermediate was obtained (Table 2, entry 1). Thus a new optimiza-

**Table 2:** Optimization of the reaction conditions for the synthesis of dithiocarbamates.


Entry	Solvent	Base	Temp. [°C]	Molar excess 4a/S <sub>8</sub> /base	Yield [%] <sup>a,b</sup>
1	NaH	THF	40	2:2:2	0 <sup>c</sup>
2	NaOH	DMSO	40	2:2:2	22
3	NaOH	DMSO	70	2:2:2	38
4	NaOH	DMSO	100	2:2:2	34
5	NaOH	DMSO	70	3:3:3	23
6	NaH	DMSO	70	2:2:2	36
7	Cs <sub>2</sub> CO <sub>3</sub>	DMSO	70	2:2:2	14
8	NaOH	DMF	70	2:2:2	43
9	NaOH	DMA	70	2:2:2	45
10	NaOH	NMP	70	2:2:2	34
11	NaOH	DMA	70	2:1.2:2	59

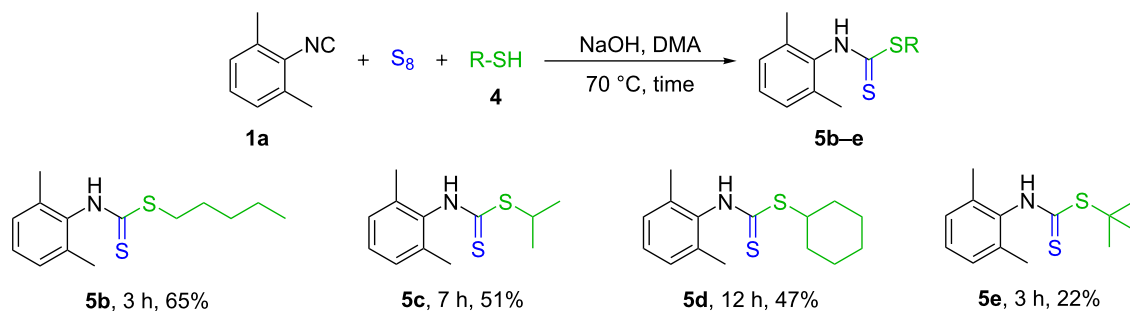
<sup>a</sup>Reaction conditions: **1a** (1 mmol), S<sub>8</sub>, **4a**, base, solvent (3 mL), temperature, 3 h under argon atmosphere. <sup>b</sup>Isolated yield, unless noted otherwise.

<sup>c</sup>Isothiocyanate intermediate detected by HPLC–MS.

tion of the reaction conditions became necessary. Similarly to the previous methodology, the base, the solvent, the temperature and the molar excess of the reagents were changed using the model reaction of 2,6-dimethylphenyl isocyanide (**1a**), sulfur and benzyl mercaptan (**4a**, Table 2). Initially, NaOH was used in DMSO as shown in entry 2 (Table 2), providing the desired dithiocarbamate **5a** in only 22% yield [96]. In order to improve the yield, firstly the temperature was elevated to 70 °C and 100 °C to afford **5a** in 38% and 34% yield, respectively (Table 2, entries 3 and 4). Larger excesses of the reagents and the base cut back the yield to 23% (Table 2, entry 5). Using NaH instead of NaOH did not improve the yield of the reaction (Table 2, entry 6), nor did the use of Cs<sub>2</sub>CO<sub>3</sub> (Table 2, entry 7).

However, using *N,N*-dimethylformamide (DMF) or *N,N*-dimethylacetamide (DMA) as the solvent provided **5a** in 43% and 45% yield, respectively (Table 2, entries 8 and 9), while on the other hand, *N*-methyl-2-pyrrolidone (NMP) was disadvantageous for the reaction (Table 2, entry 10). It is well-known that at elevated temperatures sulfur may act as an oxidant, which in this case may have compromised the reaction [97–99]. Therefore, the molar excess of sulfur was decreased, providing a positive effect on the reaction affording **5a** in 59% yield.

With the optimized reaction conditions in hand, a number of dithiocarbamate derivatives were synthesized (Scheme 4). One might notice the same trend as in the case of thiocarbamates



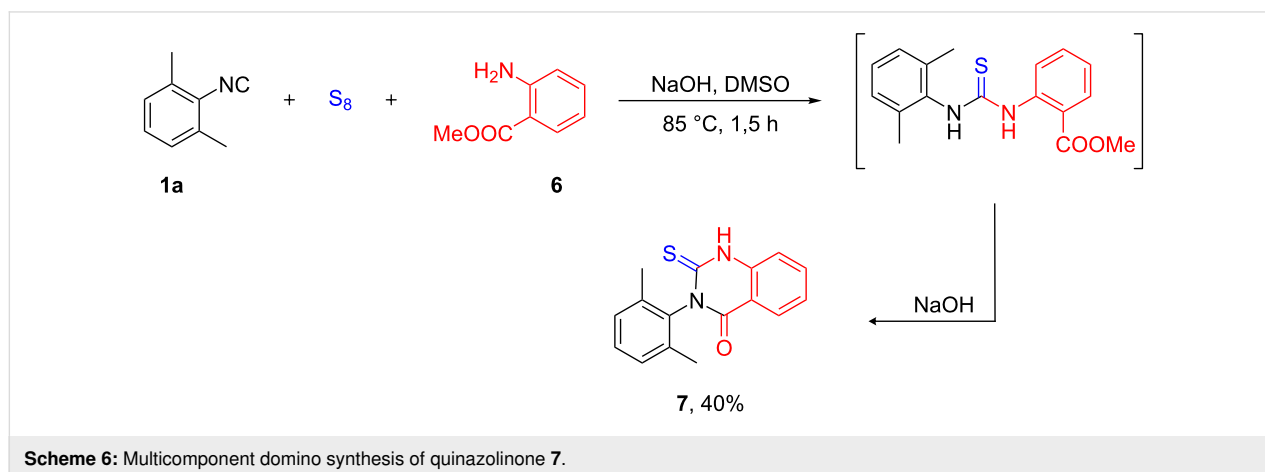
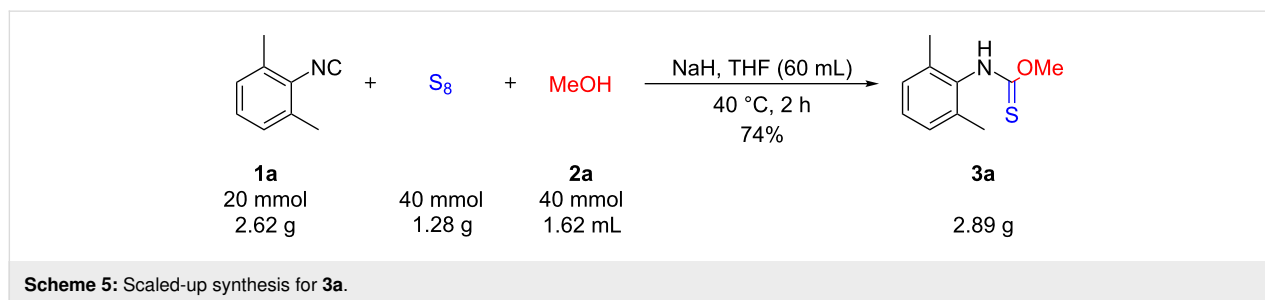
**Scheme 4:** Substrate scope of thiols. Reaction conditions: **1a** (1 mmol), S<sub>8</sub> (1.2 mmol), **4** (2 mmol), NaOH (2 mmol), DMAc (3 mL), time, under argon atmosphere at 70 °C. Yields refer to isolated yields.

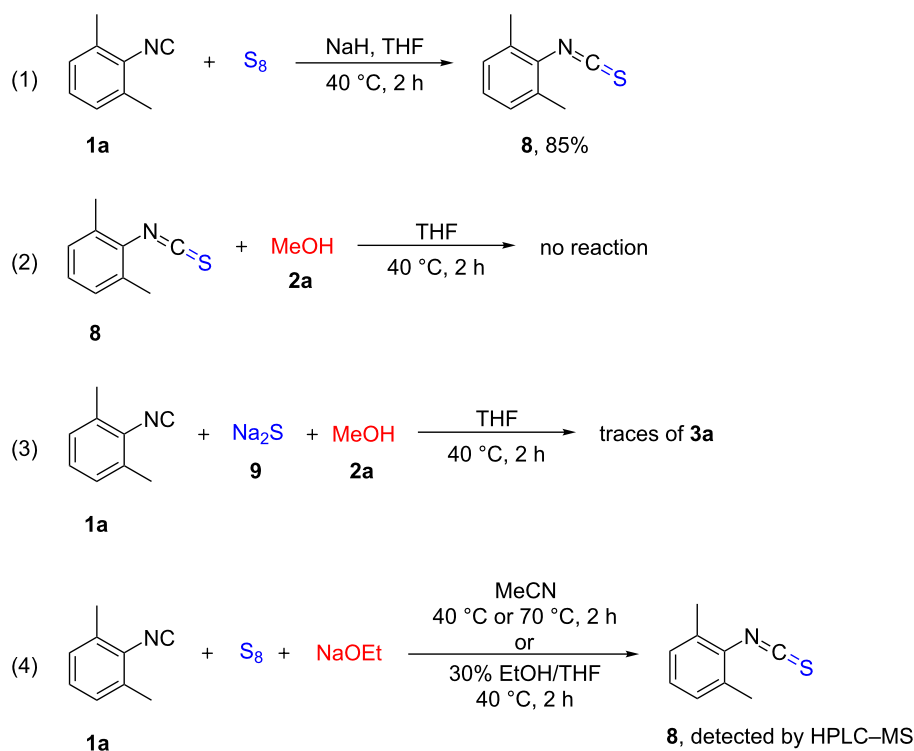
**3g–i**, in particular, the primary mercaptans gave the highest yields (**5a** and **5b**), while in the case of secondary (**5c** and **5d**) and tertiary thiols (**5e**) the products were isolated in lower yields. Although a full conversion of the isocyanide to the isothiocyanate intermediate was observed by TLC and HPLC–MS, thiophenol, likewise to phenol was unreactive under the standard reaction conditions. The generally lower yields, harsher reaction conditions and stronger negative effect of electron-donating groups might be explained with the softer nucleophilicity of the thiols compared to the alcohols [100]. All five dithiocarbamate derivatives synthesized are new and were characterized by  $^1\text{H}$  NMR,  $^{13}\text{C}$  NMR, HRMS and melting point.

After the successful application of various nucleophiles, it was our intention to investigate the scalability of the procedure. Thus, a twenty-fold scale-up of the reaction between the isocyanide **1a**, sulfur and methanol (**2a**) was performed (Scheme 5). In this case, the experimental conditions were necessarily slightly different, as in larger quantities the reaction between the alcohol and NaH needs to be kept under control. Therefore, the mixture of **1a**, methanol and THF was added dropwise to a mixture of NaH and sulfur in THF under ice-cooling. After the work-up, no chromatography was necessary and the crude product was purified by recrystallization from hexane/ethyl acetate. The three collected crops of crystals provided the thiocarbamate **3a** in a total of 74% yield.

We have envisaged that our multicomponent reaction could be compatible with subsequent one-pot transformations. In order to demonstrate this capability, we performed the multicomponent domino annulation between isocyanide **1a**, sulfur and methyl anthranilate (**6**) in DMSO in the presence of NaOH at 85 °C that provided 3-(2,6-dimethylphenyl)-2-thioxo-2,3-dihydroquinazolin-4(1*H*)-one (**7**), a new quinazolinone derivative in 40% yield (Scheme 6). Notably, these heterocycles are known for their use as antitumor [101], anticonvulsant [102] or epidermal growth factor receptor tyrosine kinase inhibitory agents [103], JNK inhibitors [104] or 5-HT<sub>3</sub> antagonists [105]. Earlier, a one-pot synthesis of an analogous compound was accomplished by Sayahi et al. starting from isothiocyanates in the presence of CuBr [106].

As aforementioned, in some cases only isothiocyanate **8** was detected and/or isolated. Thus, in order to gain mechanistic insights on the generation of **3a**, we performed a series of experiments (Scheme 7). As shown in Table 1, isocyanide **1a** and sulfur did not react in the absence of a base (Table 1, entry 21). Therefore, the reaction was performed in the presence of NaH under the standard reaction conditions, providing **8** in 85% yield (Scheme 7, reaction 1). Notably, the analogous reaction reported by Tan and co-workers using potassium *tert*-butylate in *t*-BuOH/dioxane at 55 °C for 6 h resulted in the desired isothiocyanate in only 34% yield [69]. In the next step, we investi-



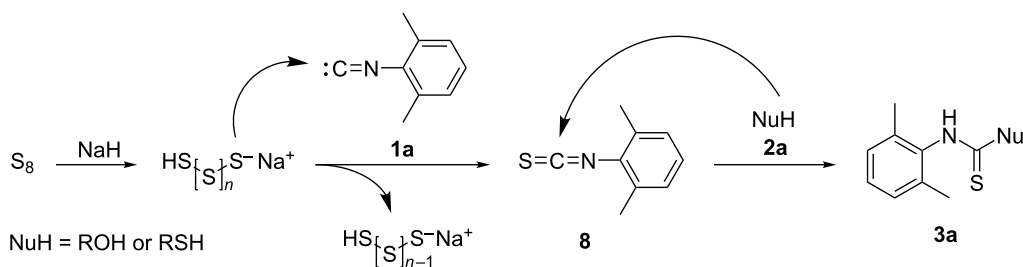


Scheme 7: Control experiments.

gated the acylation of the alcohol component by the isothiocyanate (Scheme 7, reaction 2). In the absence of a base, no reaction occurred, and consequently the base was necessary for both steps of the thiocarbamate formation. This also explains why two equivalents of base were required. Sodium sulfide as the base provided only traces of **3a** suggesting that the activation of sulfur by NaH produces rather a polysulfide anion instead of sodium sulfide [74,107,108] (Scheme 7, reaction 3). It caught our attention that only isothiocyanate was generated in the presence of NaOEt (Table 1, entry 20). We suspected that THF might not be the best solvent for this base, hence the reaction was performed in MeCN providing exclusively **8** both at

40 °C and 70 °C, and the same result was obtained when a solvent mixture of ethanol and THF was used (Scheme 7, reaction 4).

Based on the above experimental results and previous reports [74,107,108], a possible reaction mechanism has been proposed (Scheme 8). Initially, the reaction of elemental sulfur and NaH generates a polysulfide anion that is able to attack the carbenoid carbon atom of isocyanide **1a** yielding the isothiocyanate intermediate **8**. Then, the present nucleophile (NuH, alcohol or thiol) undergoes a nucleophilic addition on **8** providing thiocarbamate **3a**.



Scheme 8: Proposed mechanism.

## Conclusion

In summary, we have developed an efficient, convenient and scalable multicomponent method for the synthesis of *O*-thiocarbamates and dithiocarbamates under mild reaction conditions. This approach includes an improved catalyst-free synthesis of isothiocyanates from elemental sulfur and isocyanides, and shows good functional group tolerance to halogen, olefin and nitrile groups among others. Moreover, this multicomponent reaction is suitable for a one-pot cascade annulation providing a thioxo dihydroquinazolinone derivative in a metal-free approach. Compared to other reported syntheses of thiocarbamates, this method is highlighted by its simplicity, atom economical nature and green operational method. Out of the 29 synthesized compounds, 18 new *O*-thiocarbamates, 5 new dithiocarbamates and 1 new thioxodihydroquinazolinone were characterized.

## Supporting Information

### Supporting Information File 1

Experimental procedures, characterization data and copies of NMR spectra.

[<https://www.beilstein-journals.org/bjoc/content/supplementary/1860-5397-15-155-S1.pdf>]

## Acknowledgements

The authors thank Renáta Szabó for her contribution, and Krisztina Németh and Pál Szabó for the HRMS measurements. P. Ábrányi-Balogh was supported by the Hungarian Science Foundation OTKA (PD124598) grant.

## ORCID® iDs

András György Németh - <https://orcid.org/0000-0002-3580-4266>

György Miklós Keserű - <https://orcid.org/0000-0003-1039-7809>

Péter Ábrányi-Balogh - <https://orcid.org/0000-0002-9284-5160>

## References

- Len, C.; Postel, D.; Ronco, G.; Villa, P.; Goubert, C.; Jeurfaut, E.; Mathon, B.; Simon, H. *J. Agric. Food Chem.* **1997**, *45*, 3–6. doi:10.1021/jf9607371
- Zhou, Y.; Wang, L.; Han, L.; Meng, F.; Yang, C. *Carbohydr. Res.* **2009**, *344*, 1289–1296. doi:10.1016/j.carres.2009.05.008
- Ryder, N. S.; Frank, I.; Dupont, M.-C. *Antimicrob. Agents Chemother.* **1986**, *29*, 858–860. doi:10.1128/aac.29.5.858
- Spallarossa, A.; Cesarini, S.; Schenone, S.; Ranise, A. *Arch. Pharm. (Weinheim, Ger.)* **2009**, *342*, 344–352. doi:10.1002/ardp.200800212
- Wood, T. F.; Gardner, J. H. *J. Am. Chem. Soc.* **1941**, *63*, 2741–2742. doi:10.1021/ja01855a068
- Lin, G.; Shieh, C.-T.; Ho, H.-C.; Chouhwang, J.-Y.; Lin, W.-Y.; Lu, C.-P. *Biochemistry* **1999**, *38*, 9971–9981. doi:10.1021/bi982775e
- Cesarini, S.; Spallarossa, A.; Ranise, A.; Fossa, P.; La Colla, P.; Sanna, G.; Collu, G.; Loddò, R. *Bioorg. Med. Chem.* **2008**, *16*, 4160–4172. doi:10.1016/j.bmc.2007.12.050
- Cesarini, S.; Spallarossa, A.; Ranise, A.; Bruno, O.; La Colla, P.; Secci, B.; Collu, G.; Loddò, R. *Bioorg. Med. Chem.* **2008**, *16*, 4173–4185. doi:10.1016/j.bmc.2007.12.046
- Spallarossa, A.; Cesarini, S.; Ranise, A.; Bruno, O.; Schenone, S.; La Colla, P.; Collu, G.; Sanna, G.; Secci, B.; Loddò, R. *Eur. J. Med. Chem.* **2009**, *44*, 1650–1663. doi:10.1016/j.ejmech.2008.09.024
- Cichero, E.; Cesarini, S.; Fossa, P.; Spallarossa, A.; Mosti, L. *Eur. J. Med. Chem.* **2009**, *44*, 2059–2070. doi:10.1016/j.ejmech.2008.10.014
- Spallarossa, A.; Cesarini, S.; Ranise, A.; Schenone, S.; Bruno, O.; Borassi, A.; La Colla, P.; Pezzullo, M.; Sanna, G.; Collu, G.; Secci, B.; Loddò, R. *Eur. J. Med. Chem.* **2009**, *44*, 2190–2201. doi:10.1016/j.ejmech.2008.10.032
- Zhou, L.; Tan, C. K.; Jiang, X.; Chen, F.; Yeung, Y.-Y. *J. Am. Chem. Soc.* **2010**, *132*, 15474–15476. doi:10.1021/ja1048972
- Tan, C. K.; Zhou, L.; Yeung, Y.-Y. *Org. Lett.* **2011**, *13*, 2738–2741. doi:10.1021/ol200840e
- Zhou, L.; Chen, J.; Tan, C. K.; Yeung, Y.-Y. *J. Am. Chem. Soc.* **2011**, *133*, 9164–9167. doi:10.1021/ja201627h
- Han, W.-Y.; Li, S.-W.; Wu, Z.-J.; Zhang, X.-M.; Yuan, W.-C. *Chem. – Eur. J.* **2013**, *19*, 5551–5556. doi:10.1002/chem.201300206
- Tan, C. K.; Er, J. C.; Yeung, Y.-Y. *Tetrahedron Lett.* **2014**, *55*, 1243–1246. doi:10.1016/j.tetlet.2014.01.009
- Tay, D. W.; Leung, G. Y. C.; Yeung, Y.-Y. *Angew. Chem., Int. Ed.* **2014**, *53*, 5161–5164. doi:10.1002/anie.201310136
- Steiger, A. K.; Pardue, S.; Kevil, C. G.; Pluth, M. D. *J. Am. Chem. Soc.* **2016**, *138*, 7256–7259. doi:10.1021/jacs.6b03780
- Yoshida, S.; Hayashi, Y.; Obitsu, K.; Nakamura, A.; Kikuchi, T.; Sawada, T.; Kimura, T.; Takahashi, T.; Mukuta, T. *Org. Process Res. Dev.* **2012**, *16*, 1818–1826. doi:10.1021/op300237b
- Yadav, J. S.; Goreti, R.; Pabbaraja, S.; Sridhar, B. *Org. Lett.* **2013**, *15*, 3782–3785. doi:10.1021/ol401760e
- Heyns, A. Y.; Carter, G. A.; Rothwell, K.; Wain, R. L. *Ann. Appl. Biol.* **1966**, *57*, 33–51. doi:10.1111/j.1744-7348.1966.tb06864.x
- Rafin, C.; Veignie, E.; Sancholle, M.; Postel, D.; Len, C.; Villa, P.; Ronco, G. *J. Agric. Food Chem.* **2000**, *48*, 5283–5287. doi:10.1021/jf0003698
- MacBean, C. *The Pesticide Manual*, 16th ed.; British Crop Production Council, 2012.
- Gupta, P. K. Herbicides and fungicides. In *Biomarkers in Toxicology*; Gupta, R. C., Ed.; Academic Press: Cambridge, MA, USA, 2014; pp 409–431. doi:10.1016/b978-0-12-404630-6.00024-5
- Thind, T. S.; Hollomon, D. W. *Pest Manage. Sci.* **2018**, *74*, 1547–1551. doi:10.1002/ps.4844
- Carta, F.; Aggarwal, M.; Maresca, A.; Scozzafava, A.; McKenna, R.; Masini, E.; Supuran, C. T. *J. Med. Chem.* **2012**, *55*, 1721–1730. doi:10.1021/jm300031j
- Schwimmer, A.; Rubin, D. Method and compositions for inhibiting tumor cell metabolism. U.S. Patent US5,240,914, Aug 31, 1993.
- Boas, U.; Gertz, H.; Christensen, J. B.; Heegaard, P. M. H. *Tetrahedron Lett.* **2004**, *45*, 269–272. doi:10.1016/j.tetlet.2003.10.182
- Hatai, J.; Pal, S.; Jose, G. P.; Bandyopadhyay, S. *Inorg. Chem.* **2012**, *51*, 10129–10135. doi:10.1021/ic300530f

30. Konieczna, D. D.; Blanrue, A.; Wilhelm, R. *Z. Naturforsch., B: J. Chem. Sci.* **2014**, *69*, 596–604. doi:10.5560/znb.2014-4014
31. Seetharamsingh, B.; Ramesh, R.; Dange, S. S.; Khairnar, P. V.; Singhal, S.; Upadhyay, D.; Veeraraghavan, S.; Viswanadha, S.; Vakkalanka, S.; Reddy, D. S. *ACS Med. Chem. Lett.* **2015**, *6*, 1105–1110. doi:10.1021/acsmchemlett.5b00213
32. Selvakumar, N.; Kumar, G. S.; Malar Azhagan, A.; Govinda Rajulu, G.; Sharma, S.; Kumar, M. S.; Das, J.; Iqbal, J.; Trehan, S. *Eur. J. Med. Chem.* **2007**, *42*, 538–543. doi:10.1016/j.ejmech.2006.10.013
33. Sasse, K. *Justus Liebigs Ann. Chem.* **1970**, *735*, 158–188. doi:10.1002/jlac.19707350120
34. Barma, D. K.; Bandyopadhyay, A.; Capdevila, J. H.; Falck, J. R. *Org. Lett.* **2003**, *5*, 4755–4757. doi:10.1021/ol0354573
35. Kojima, M.; Nakamura, Y.; Ishikawa, T.; Takeuchi, S. *Tetrahedron Lett.* **2006**, *47*, 6309–6314. doi:10.1016/j.tetlet.2006.05.142
36. Iwakawa, T.; Tamura, H.; Murabayashi, A.; Hayase, Y. *Chem. Pharm. Bull.* **1991**, *39*, 1939–1943. doi:10.1248/cpb.39.1939
37. Koketsu, M.; Otsuka, T.; Ishihara, H. *Phosphorus, Sulfur Silicon Relat. Elem.* **2004**, *179*, 443–448. doi:10.1080/104265004902626212
38. Gromek, S. M.; deMayo, J. A.; Maxwell, A. T.; West, A. M.; Pavlik, C. M.; Zhao, Z.; Li, J.; Wiemer, A. J.; Zweifach, A.; Balunas, M. J. *Bioorg. Med. Chem.* **2016**, *24*, 5183–5196. doi:10.1016/j.bmc.2016.08.040
39. Schrader, A. M.; Schroll, A. L.; Barany, G. *J. Org. Chem.* **2011**, *76*, 7882–7892. doi:10.1021/jo201329n
40. Boeckman, R. K.; Ge, P.; Reed, J. E. *Org. Lett.* **2001**, *3*, 3647–3650. doi:10.1021/ol0165645
41. Steiger, A. K.; Zhao, Y.; Choi, W. J.; Crammond, A.; Tillotson, M. R.; Pluth, M. D. *Biochem. Pharmacol.* **2018**, *149*, 124–130. doi:10.1016/j.bcp.2017.11.004
42. Ranu, B. C.; Saha, A.; Banerjee, S. *Eur. J. Org. Chem.* **2008**, 519–523. doi:10.1002/ejoc.200700842
43. Safa, K. D.; Tavakkoli Osgoei, S.; Alyari, M. J. *Sulfur Chem.* **2014**, *35*, 683–690. doi:10.1080/17415993.2014.953163
44. Halimehiani, A. Z.; Hooshmand, S. E.; Shamiri, E. V. *Tetrahedron Lett.* **2014**, *55*, 5454–5457. doi:10.1016/j.tetlet.2014.08.017
45. Halimehiani, A. Z.; Martens, J.; Schlüter, T. *Tetrahedron* **2016**, *72*, 3958–3965. doi:10.1016/j.tet.2016.05.025
46. Modarresi-Alam, A. R.; Inaloo, I. D.; Kleinpeter, E. *J. Mol. Struct.* **2012**, *1024*, 156–162. doi:10.1016/j.molstruc.2012.05.033
47. Tsuji, K.; Nakamura, K.; Konishi, N.; Okumura, H.; Matsuo, M. *Chem. Pharm. Bull.* **1992**, *40*, 2399–2409. doi:10.1248/cpb.40.2399
48. Hagooley, Y.; Gateno, J.; Hagooley, A.; Rozen, S. *J. Org. Chem.* **2009**, *74*, 8578–8582. doi:10.1021/jo901560b
49. Ranade, S. C.; Hasty, S. J.; Demchenko, A. V. *J. Carbohydr. Chem.* **2013**, *32*, 360–379. doi:10.1080/07328303.2013.826670
50. Chniti, I.; Sanhoury, M. A. K.; Chehidi, I. *J. Fluorine Chem.* **2013**, *156*, 101–105. doi:10.1016/j.jfluchem.2013.09.008
51. Chniti, I.; Sanhoury, M. A. K.; Merlet, D.; Chehidi, I. *J. Fluorine Chem.* **2014**, *168*, 223–229. doi:10.1016/j.jfluchem.2014.10.015
52. Liu, X.; Wang, Z.; Xie, R.; Tang, P.; Yuan, Q. *Eur. J. Med. Chem.* **2018**, *157*, 1526–1540. doi:10.1016/j.ejmech.2018.07.038
53. Wróblewska, A.; Młostoń, G. *Phosphorus, Sulfur Silicon Relat. Elem.* **2013**, *188*, 509–511. doi:10.1080/10426507.2012.736897
54. Zhu, J.-B.; Chen, E. Y.-X. *J. Am. Chem. Soc.* **2015**, *137*, 12506–12509. doi:10.1021/jacs.5b08658
55. Bassetto, M.; Ferla, S.; Pertusati, F.; Kandil, S.; Westwell, A. D.; Brancale, A.; McGuigan, C. *Eur. J. Med. Chem.* **2016**, *118*, 230–243. doi:10.1016/j.ejmech.2016.04.052
56. Cai, W.; Wu, J.; Liu, W.; Xie, Y.; Liu, Y.; Zhang, S.; Xu, W.; Tang, L.; Wang, J.; Zhao, G. *Molecules* **2018**, *23*, No. 252. doi:10.3390/molecules23020252
57. Larsen, C.; Steliou, K.; Harpp, D. N. *J. Org. Chem.* **1978**, *43*, 337–339. doi:10.1021/jo00396a035
58. Kim, S.; Yi, K. Y. *Tetrahedron Lett.* **1985**, *26*, 1661–1664. doi:10.1016/s0040-4039(00)98578-2
59. Wong, R.; Dolman, S. J. *J. Org. Chem.* **2007**, *72*, 3969–3971. doi:10.1021/jo070246n
60. Nath, J.; Ghosh, H.; Yella, R.; Patel, B. K. *Eur. J. Org. Chem.* **2009**, 1849–1851. doi:10.1002/ejoc.200801270
61. Zhang, X.; Lee, Y. K.; Kelley, J. A.; Burke, T. R. *J. Org. Chem.* **2000**, *65*, 6237–6240. doi:10.1021/jo000139s
62. Li, Z.-Y.; Ma, H.-Z.; Han, C.; Xi, H.-T.; Meng, Q.; Chen, X.; Sun, X.-Q. *Synthesis* **2013**, *45*, 1667–1674. doi:10.1055/s-0033-1338744
63. Jae Nyoung, K.; Ryu, E. K. *Tetrahedron Lett.* **1993**, *34*, 8283–8284. doi:10.1016/s0040-4039(00)61411-9
64. Kim, J. N.; Jung, K. S.; Lee, H. J.; Son, J. S. *Tetrahedron Lett.* **1997**, *38*, 1597–1598. doi:10.1016/s0040-4039(97)00121-4
65. Baumann, M.; Baxendale, I. R. *Beilstein J. Org. Chem.* **2013**, *9*, 1613–1619. doi:10.3762/bjoc.9.184
66. Tanaka, S.; Uemura, S.; Okano, M. *Bull. Chem. Soc. Jpn.* **1977**, *50*, 2785–2788. doi:10.1246/bcsj.50.2785
67. Bachi, M. D.; Balanov, A.; Bar-Ner, N. *J. Org. Chem.* **1994**, *59*, 7752–7758. doi:10.1021/jo00104a035
68. Bachi, M. D.; Melman, A. *J. Org. Chem.* **1995**, *60*, 6242–6244. doi:10.1021/jo00124a056
69. Szabó, T.; Milen, M. *Chem. Heterocycl. Compd.* **2019**, *55*, 126–128. doi:10.1007/s10593-019-02427-3
70. Tan, W.; Wei, J.; Jiang, X. *Org. Lett.* **2017**, *19*, 2166–2169. doi:10.1021/acs.orglett.7b00819
71. Reiffen, M.; Hoffmann, R. W. *Chem. Ber.* **1977**, *110*, 37–48. doi:10.1002/cber.19771100105
72. Cunico, R. F.; Maity, B. C. *Org. Lett.* **2003**, *5*, 4947–4949. doi:10.1021/ol030110l
73. Mampuy, P.; Zhu, Y.; Vlaar, T.; Ruijter, E.; Orru, R. V. A.; Maes, B. U. W. *Angew. Chem., Int. Ed.* **2014**, *53*, 12849–12854. doi:10.1002/anie.201406717
74. Nguyen, T. B.; Ermolenko, L.; Al-Mourabit, A. *Synthesis* **2014**, *46*, 3172–3179. doi:10.1055/s-0034-1379327
75. Pathare, R. S.; Patil, V.; Kaur, H.; Maurya, A. K.; Agnihotri, V. K.; Khan, S.; Devunuri, N.; Sharon, A.; Sawant, D. M. *Org. Biomol. Chem.* **2018**, *16*, 8263–8266. doi:10.1039/c8ob01855c
76. Boyer, J. H.; Ramakrishnan, V. T. *J. Org. Chem.* **1972**, *37*, 1360–1364. doi:10.1021/jo00974a016
77. Zajdlík, A.; Wang, Z.; Hickey, J. L.; Aman, A.; Schimmer, A. D.; Yudin, A. K. *Angew. Chem., Int. Ed.* **2013**, *52*, 8411–8415. doi:10.1002/anie.201302818
78. Adam, W.; Bargon, R. M.; Bosio, S. G.; Schenk, W. A.; Stalke, D. *J. Org. Chem.* **2002**, *67*, 7037–7041. doi:10.1021/jo026042i
79. Arisawa, M.; Ashikawa, M.; Suwa, A.; Yamaguchi, M. *Tetrahedron Lett.* **2005**, *46*, 1727–1729. doi:10.1016/j.tetlet.2005.01.069
80. Farrell, W. S.; Zavalij, P. Y.; Sita, L. R. *Organometallics* **2016**, *35*, 2361–2366. doi:10.1021/acs.organomet.6b00302

81. Chakrabarty, S.; Choudhary, S.; Doshi, A.; Liu, F.-Q.; Mohan, R.; Ravindra, M. P.; Shah, D.; Yang, X.; Fleming, F. F. *Adv. Synth. Catal.* **2014**, *356*, 2135–2196. doi:10.1002/adsc.201400017
82. Boyarskiy, V. P.; Bokach, N. A.; Luzyanin, K. V.; Kukushkin, V. Y. *Chem. Rev.* **2015**, *115*, 2698–2779. doi:10.1021/cr500380d
83. Fujiwara, S.-i.; Shin-Ike, T.; Okada, K.; Aoki, M.; Kambe, N.; Sonoda, N. *Tetrahedron Lett.* **1992**, *33*, 7021–7024. doi:10.1016/s0040-4039(00)60922-x
84. Feng, W.; Zhang, X.-G. *Chem. Commun.* **2019**, *55*, 1144–1147. doi:10.1039/c8cc09190k
85. Milen, M.; Ábrányi-Balogh, P.; Dancsó, A.; Frigyes, D.; Pongó, L.; Keglevich, G. *Tetrahedron Lett.* **2013**, *54*, 5430–5433. doi:10.1016/j.tetlet.2013.07.145
86. Ábrányi-Balogh, P.; Dancsó, A.; Frigyes, D.; Volk, B.; Keglevich, G.; Milen, M. *Tetrahedron* **2014**, *70*, 5711–5719. doi:10.1016/j.tet.2014.06.073
87. Varga, V.; Milen, M.; Ábrányi-Balogh, P. *Tetrahedron Lett.* **2018**, *59*, 3683–3689. doi:10.1016/j.tetlet.2018.08.063
88. Milen, M.; Slégel, P.; Keglevich, P.; Keglevich, G.; Simig, G.; Volk, B. *Tetrahedron Lett.* **2015**, *56*, 5697–5700. doi:10.1016/j.tetlet.2015.09.007
89. Henderson, R. K.; Jiménez-González, C.; Constable, D. J. C.; Alston, S. R.; Inglis, G. G. A.; Fisher, G.; Sherwood, J.; Binks, S. P.; Curzons, A. D. *Green Chem.* **2011**, *13*, 854–862. doi:10.1039/c0gc00918k
90. McConvey, I. F.; Woods, D.; Lewis, M.; Gan, Q.; Nancarrow, P. *Org. Process Res. Dev.* **2012**, *16*, 612–624. doi:10.1021/op2003503
91. Niknam, K.; Kiasat, A. R.; Kazemi, F.; Hossieni, A. *Phosphorus, Sulfur Silicon Relat. Elem.* **2003**, *178*, 1385–1389. doi:10.1080/10426500307905
92. Burrows, A. A.; Hunter, L. J. *J. Chem. Soc.* **1952**, *0*, 4118–4122. doi:10.1039/jr9520004118
93. Degani, I.; Fochi, R.; Magistris, C. *Synthesis* **2009**, 3807–3818. doi:10.1055/s-0029-1218117
94. L'Abbé, G.; Sorgeloos, D.; Toppet, S.; King, G. S. D.; Van Meerwelt, L. *Bull. Soc. Chim. Belg.* **1981**, *90*, 63–74. doi:10.1002/bscb.19810900111
95. Lijuan, M.; Shubai, L.; Lili, S.; Mengqi, W. Method for preparing multi-functional sulfide-bonded collaborative antioxidative stabilizer. Chin. Patent Appl. CN 104529875 A, April 22, 2015.
96. Labib, M. B.; Lamie, P. F. *Med. Chem. Res.* **2016**, *25*, 2607–2618. doi:10.1007/s00044-016-1703-y
97. Nguyen, T. B.; Ermolenko, L.; Retailleau, P.; Al-Mourabit, A. *Angew. Chem., Int. Ed.* **2014**, *53*, 13808–13812. doi:10.1002/anie.201408397
98. Nguyen, L. A.; Ngo, Q. A.; Retailleau, P.; Nguyen, T. B. *Green Chem.* **2017**, *19*, 4289–4293. doi:10.1039/c7gc01825h
99. Nguyen, T. B.; Retailleau, P. *Org. Lett.* **2017**, *19*, 3887–3890. doi:10.1021/acs.orglett.7b01775
100. Clayden, J.; Greeves, N.; Warren, S.; Wothers, P. *Conjugate addition. Organic Chemistry*; Oxford University Press: Oxford, U.K., 2001; pp 227–242.
101. Al-Suwaidan, I. A.; Alanazi, A. M.; Abdel-Aziz, A. A.-M.; Mohamed, M. A.; El-Azab, A. S. *Bioorg. Med. Chem. Lett.* **2013**, *23*, 3935–3941. doi:10.1016/j.bmcl.2013.04.056
102. Jatav, V.; Mishra, P.; Kashaw, S.; Stables, J. P. *Eur. J. Med. Chem.* **2008**, *43*, 1945–1954. doi:10.1016/j.ejmech.2007.12.003
103. Smail, J. B.; Gonzales, A. J.; Spicer, J. A.; Lee, H.; Reed, J. E.; Sexton, K.; Althaus, I. W.; Zhu, T.; Black, S. L.; Blaser, A.; Denny, W. A.; Ellis, P. A.; Fakhoury, S.; Harvey, P. J.; Hook, K.; McCarthy, F. O. J.; Palmer, B. D.; Rivault, F.; Schlosser, K.; Ellis, T.; Thompson, A. M.; Trachet, E.; Winters, R. T.; Teclé, H.; Bridges, A. *J. Med. Chem.* **2016**, *59*, 8103–8124. doi:10.1021/acs.jmedchem.6b00883
104. Noble, M. E.; Endicott, J. A.; Johnson, L. N. *Science* **2004**, *303*, 1800–1805. doi:10.1126/science.1095920
105. Asagarasu, A.; Matsui, T.; Hayashi, H.; Tamaoki, S.; Yamauchi, Y.; Minato, K.; Sato, M. *J. Med. Chem.* **2010**, *53*, 7549–7563. doi:10.1021/jm1002292
106. Sayahi, M. H.; Saghanezhad, S. J.; Bahadorikhalili, S.; Mahdavi, M. *Appl. Organomet. Chem.* **2019**, *33*, e4635. doi:10.1002/aoc.4635
107. Okamoto, K.; Yamamoto, T.; Kanbara, T. *Synlett* **2007**, 2687–2690. doi:10.1055/s-2007-991073
108. Chen, H.-Y.; Peng, W.-T.; Lee, Y.-H.; Chang, Y.-L.; Chen, Y.-J.; Lai, Y.-C.; Jheng, N.-Y.; Chen, H.-Y. *Organometallics* **2013**, *32*, 5514–5522. doi:10.1021/om400784w

## License and Terms

This is an Open Access article under the terms of the Creative Commons Attribution License (<http://creativecommons.org/licenses/by/4.0>). Please note that the reuse, redistribution and reproduction in particular requires that the authors and source are credited.

The license is subject to the *Beilstein Journal of Organic Chemistry* terms and conditions: (<https://www.beilstein-journals.org/bjoc>)

The definitive version of this article is the electronic one which can be found at: [doi:10.3762/bjoc.15.155](https://doi.org/10.3762/bjoc.15.155)